

Model 510 Seismic Actuated Electrical Switch

Emergency Shut-Off System



The Model ES510 Seismic Switch is a seismically actuated electrical switch. This unique device, when configured properly, will cut electrical power to just about any device during a seismic event. It is mounted securely to the building via mounting brackets and leveled using chain site. The protected device's power is wired with the 510 and other customer provided hardware thus providing seismic protection. PSP's Seismic Switch can be used to protect a variety of electrical devices, such as a local electrical pump or even an entire factory, when properly installed with additional hardware (not provided by PSP).



Specifications

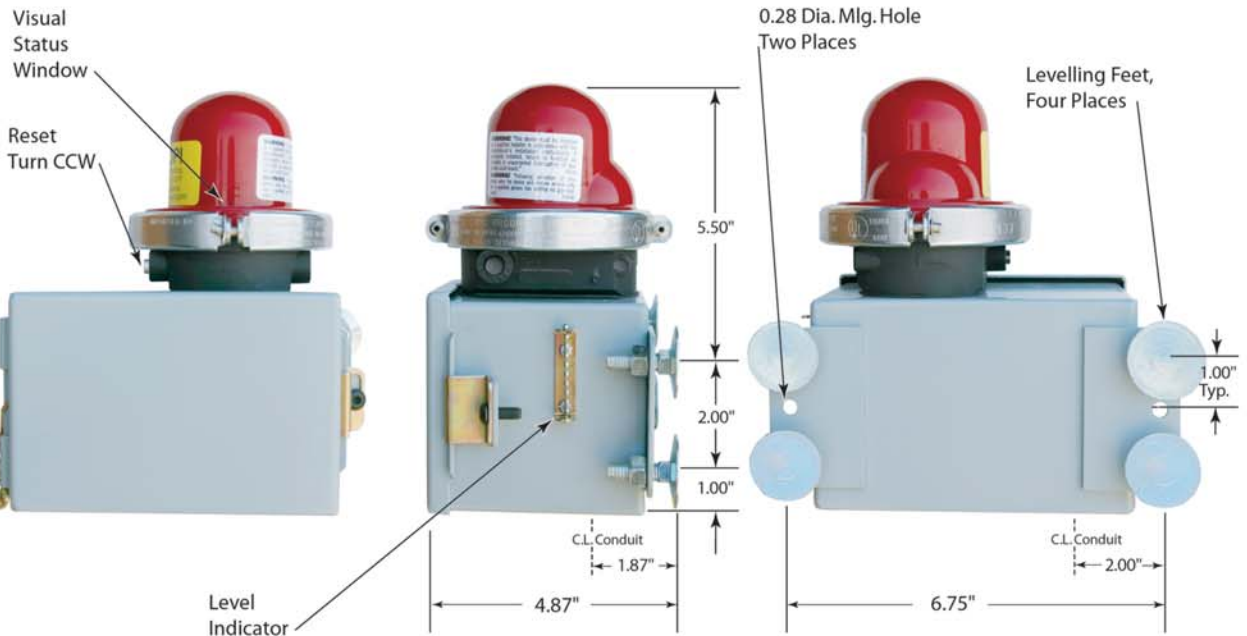

Distributed By
 Meter, Valve & Control
 877-566-3837

Pacific Seismic Products

233 East Avenue H-8 • Lancaster, CA 93535 • USA • Tel: (661) 942-4499 • Fax: (661) 942-0999

| sales@mvandc.com | Phone: 877.566.3837 | Fax: 925.407.2903

Specifications: Model 510 Seismic Switch Emergency Shut-Off System

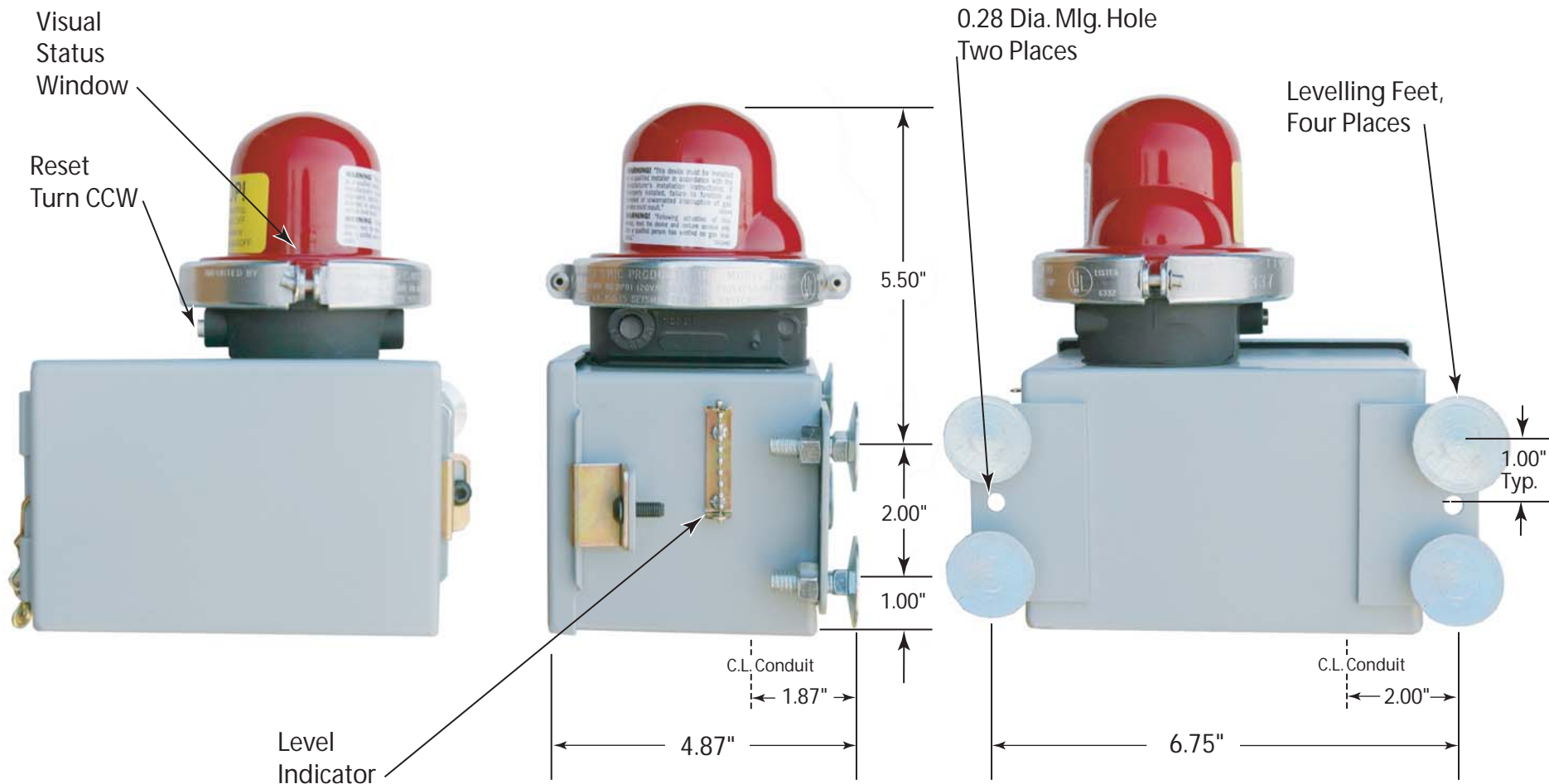

| sales@mvandc.com | Phone: 877.566.3837 | Fax: 925.407.2903

California Seismic Valves are UL listed in the USA and Canada, Certified by the California State Architect's Office, Approved by the City of Los Angeles, and are warranted free of manufacturer's defects for 30 years. All valves meet California Standards for Earthquake Actuated Automatic Gas Shut off Systems, Standard No. 12-23-1, ANSI Z21.70, 1981 and ASCE 25-97 Standards.

Pacific Seismic Products
233 East Avenue H-8 • Lancaster, CA 93535 • USA

Tel (661) 942-4499
Fax (661) 942-0999
TF (800) 4-GAS-OFF