

# PETE'S PLUG II<sup>®</sup>

The successor to the real Pete's Plug

**PETE'S PLUG II<sup>®</sup> WILL ALLOW YOU TO TAKE PRESSURE AND TEMPERATURE READINGS QUICKLY AND ELIMINATE THE NEED FOR LEAVING COSTLY GAUGES OR TEMPERATURE INDICATORS ON THE LINE.**

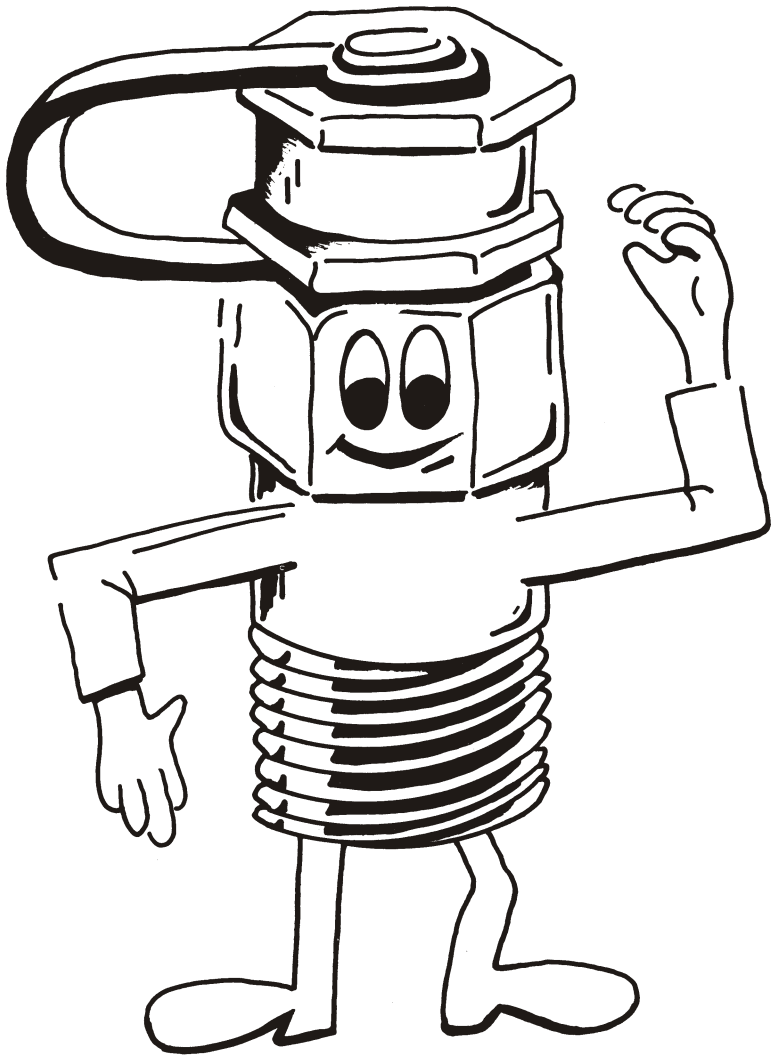

Depending on the application, the Pete's Plug can be operated to a maximum of 500 PSIG and 200° or 275°F for neoprene and norden respectively. Maximum working pressures of 1000 PSIG can be attained with neoprene or norden at temperatures from 140°F to -20°F.

**The enhanced version of Pete's Plug II<sup>®</sup> is still the only pressure and temperature test plug with two self-closing valves, but the valves are improved with interaction which speeds valve closure.**

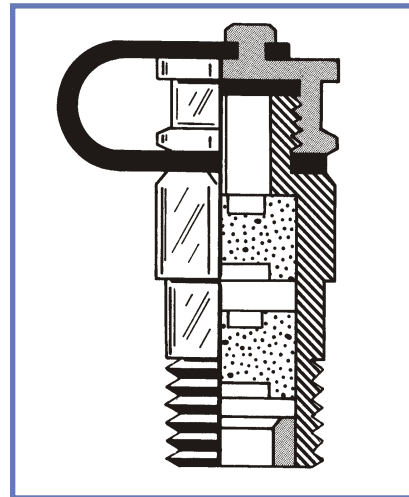

Patent Number 5,079,962



IMAC Systems, Inc  
90 Main Street, PO Box 1605  
Tullytown, PA 19007

Distributed in Your Area By:



**Meter, Valve & Control**  
**877-566-3837**

1-800-955-4GAS  
Phone: (215)946-2200  
Fax: (215) 943-2984  
Email: sales@imacsystems.com



Pete's Plug II is available in various pipe thread sizes, lengths and materials to satisfy each application. The XL Pete's Plug II will allow you to insulate the test point and not completely cover the Pete's Plug II. The XL Pete's Plug II eliminates extra fittings for insulated applications.

### Pressure or Temperature Tests

Take pressure and temperature readings quickly with line pressurized. Reduce the need for costly permanent installation of gauges and recorders on the line.

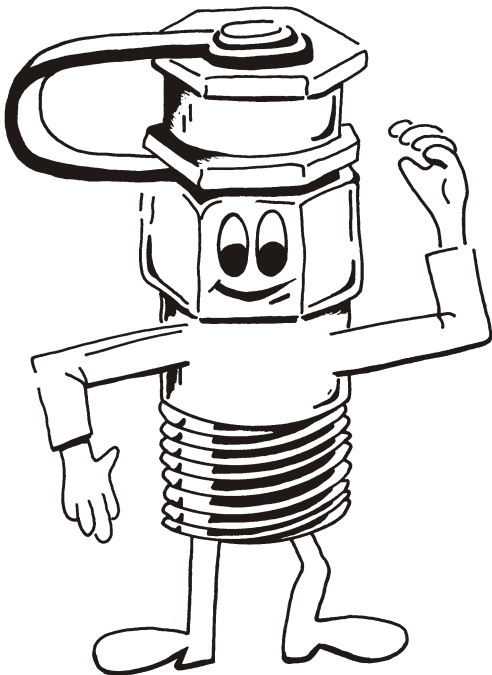

### Standard length Pete's Plug II

#### Cross Section:

1. Cap and Gasket
2. Cap retaining strap
3. Two self closing valves with interaction to speed valve closure
4. Valve body
5. Valve retainer

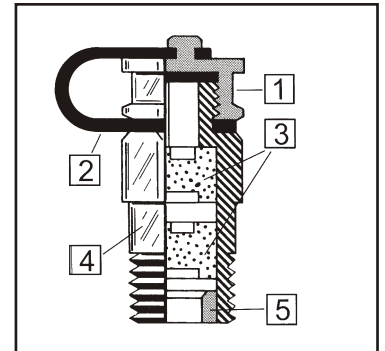

### Suggested specifications

#### Pressure and temperature test stations:

Supply and install where indicated "Pete's Plug II" a 1/4" fitting to receive either a temperature or pressure probe 1/8" OD. Fitting shall be solid brass with two valve cores of Neoprene (Max 200°F) at 500 PSI, or Nordel (Max 275°F) at 500 PSI, fitted with a color coded cap strap with gasket, and shall be rated at 1000 PSI at 140°F. In addition, the installing contractor shall supply the owner with \_\_\_ (number) pressure gauge adapters with 1/8" OD probe and \_\_\_ (number) five inch stem pocket testing thermometers; 25-125°F for chilled water and \_\_\_ (number) 0-220°F or \_\_\_ (number) 50-500°F for hot water.

#### Pressure and temperature test kit:

Supply and present to the owner upon completion of testing a pressure and temperature test kit. It will consist of a 0-100 PSI, 0-230 ft. of water pressure gauge with a Number 500 gauge adapter attached. It will contain one 25-125°F and one 0-220°F pocket testing thermometer, an extra number 500 gauge adapter, and a protective carrying case.

### How to operate

The Pete's Plug II is permanently installed in the line at recommended test points. The cap protects the valve and provides an additional seal. After the cap has been removed, either a test thermometer or a gauge adapter with the proper pressure gauge can be inserted through the two, self-closing valves in the Pete's Plug II. Readings are made, adjustments or tests can be accomplished and when the probes are withdrawn the two valves close. The protective cap is then reinstalled. Tests should be made as quickly as possible since the valve reseal time is dependent upon time of insertion, time and pressure. Slower valve reseal time can be expected at lower temperature and lower pressures.



**#1500XL test kit works with our extended length Pete's Plugs**

## Applications

In general the Pete's Plug is a time and money saving device which is well suited for most plant and pipeline systems and is designed to eliminate gauge cocks and thermometer wells. Hot and chilled water systems, heat exchangers, pumps, differential readings, air, gas lines and numerous other applications are only a few of the areas where the Pete's Plug are presently being used.

## Valve Materials

**Neoprene** is a chloroprene based synthetic rubber and is resistant to deterioration from waxes, fats, oils, greases, petroleum products and most refrigerants.

**Nordel** is an ethylene-propylene based synthetic rubber and gives excellent service in hot and cold water and in some applications of low steam. Nordel is resistant to detergents, phosphate esters, ketone, alcohols, and glycols. It is **not** suitable for petroleum products.

Neoprene and nordel are proprietary materials and the information presented herein is believed to be accurate and reliable. Peterson Equipment Co., Inc. Can assume no liability for results obtained or damages incurred through the application of this information. The information is intended as a guide and if in doubt ask!



## Pressure Tests

The pressure gauge adapter has a probe constructed of 304 stainless steel. The probe is 0.156" in diameter and extends 2 inches on the standard adapter and 3½ inches on the extra long adapter. The 1/8" diameter probe is less likely to become clogged with foreign material and resists bending. Also, the 1/8" diameter probe operates in either the ¼", 3/8", or ½" Pete's Plug. Please note the 500XL gauge adapter will operate in any of the Pete's Plug's. It is intended for use with any of the XL Pete's Plug's.

## Temperature Tests

The test thermometer is constructed of stainless steel, has a 1 3/4" dial and has a bi-metallic sensing element. Accuracy within ½ % over the entire scale can be expected. Pointer adjustment or recalibrations can be made by turning the hex nut on the back of the dial case while firmly holding the dial case. The stem should be immersed in a known, controlled temperature bath. Stem lengths are 5" and diameters of 0.156" or 4mm are maximum diameters that can be inserted onto the Pete's Plug. Digital thermometers have the same specifications but can not be recalibrated in the field.

<u>Valve Core Material</u>	<u>Recommended Maximum Temperature</u>	<u>Maximum Pressure</u>	<u>Strap Color Coded</u>
Neoprene	200°F	500PSIG	Blue Strap-Neoprene
Nordel	275°F	500PSIG	Yellow Strap-Nordel

## ORDERING INFORMATION

<u>Part Number</u>	<u>Valve Core Material</u>	<u>Size</u>	<u>Body and Cap Material</u>	<u>Length</u>
100	Neoprene	¼"NPT	Brass	1½"
110	Nordel	"	Brass	"
100XL	Neoprene	¼"NPT	Brass	3"
110XL	Nordel	"	Brass	"
300	Neoprene	3/8"NPT	Brass	1½"
310	Nordel	"	"	"
400	Neoprene	¼"NPT	316SS	1½"
410	Nordel	"	"	"
700	Neoprene	½"NPT	Brass	1½"
710	Nordel	"	Brass	"
700XL	Neoprene	½"NPT	Brass	3"
710XL	Nordel	"	Brass	"
12500	Neoprene	1/8"NPT	Brass	1¼"

Cap retaining straps are standard on all Pete's Plugs.

### Gauge Adapters (All Connections ¼"NPTF)

- 500 Gauge Adapter with 1/8" Diameter Probe
- 500XL Gauge Adapter with 1/8" Diameter Probe for XL Plugs
- 510 Gauge Adapter with 1/16" Diameter Probe\*\*
- 520 Gauge Adapter with 1/8" Diameter Probe all 316SS

### Test Kits

- 1500 Temperature and Pressure Test Kit
- 1500XL Temperature and Pressure Test Kit-XL

### Bi-Metal Pocket Testing Thermometers 5" Stem With External Calibration

<u>Part Number</u>	<u>Range</u>	<u>Degree Division</u>
600	-40° to 160°F	2
601	25° to 125°F	1
603	0° to 220°F	2

### Digital Pocket Testing Thermometers 5" Stem

<u>Part Number</u>	<u>Range</u>	<u>Degree Division</u>
606	-58° to 571°F	0.1

\*\*510 is the only gauge adapter that will fit part number 12500

U.S. Patent Number 5079962 Canadian Patent Number 981192. Patent pending in United States and other countries. All patents are sole property of the Peterson Equipment Co., Inc.® A trademark of the Peterson Equipment Company, Inc.

Distributed in Your Area By:



IMAC Systems, Inc.  
90 Main Street, PO Box 1605  
Tullyown, PA 19007



1-800-955-4GAS  
Phone: (215) 946-2200  
Fax: (215) 943-2984  
Email: sales@imacsystems.com