

Distributed By
MVC
Meter, Valve & Control
877-566-3837

**TURBINE FLOW METER
Installation and Operation Guide**



SAFETY INFORMATION

This meter was calibrated at the factory before shipment. To ensure correct use of the meter, please read this manual thoroughly.

Regarding this manual:

- This manual should be passed on to the end user.
- Before use, read this manual thoroughly to comprehend its contents.
- The contents of this manual may be changed without prior notice.
- All rights reserved. No part of this manual may be reproduced in any form without ONICON's written permission.
- ONICON makes no warranty of any kind with regard to this material, including, but not limited to, implied warranties of merchantability and suitability for a particular purpose.
- All reasonable effort has been made to ensure the accuracy of the contents of this manual. However, if any errors are found, please inform ONICON.
- ONICON assumes no responsibilities for this product except as stated in the warranty.
- If the customer or any third party is harmed by the use of this product, ONICON assumes no responsibility for any such harm owing to any defects in the product which were not predictable, or for any indirect damages.

Safety Precautions:

The following general safety precautions must be observed during all phases of installation, operation, service, and repair of this product. Failure to comply with these precautions or with specific WARNINGS given elsewhere in this manual violates safety standards of design, manufacture, and intended use of the product. ONICON Incorporated assumes no liability for the customer's failure to comply with these requirements. If this product is used in a manner not specified in this manual, the protection provided by this product may be impaired.

The following symbols are used in this manual:



WARNING

Messages identified as "WARNING" contain information regarding the personal safety of individuals involved in the installation, operation or service of this product.



CAUTION

Messages identified as "CAUTION" contain information regarding potential damage to the product or other ancillary products.



IMPORTANT NOTE

Messages identified as "IMPORTANT NOTE" contain information critical to the proper operation of the product.

TABLE OF CONTENTS

1.0	INTRODUCTION	4
1.1	Purpose of This Guide	4
1.2	Typical Turbine Flow Meters	4
1.3	Standard Features and Specifications	5
1.4	Model Numbering System	6
1.5	Additional Required Hardware	6
1.6	Warranty and Serial Number	6
2.0	UNPACKING	7
2.1	Checking That You Have Received Everything	7
3.0	INSTALLATION, REMOVAL & ADJUSTMENT	8
3.1	Site Selection	8
3.2	Insertion Meter Straight Run Requirements	10
3.3	Insertion Meter Mechanical Installation	12
3.3.1	Insertion Meter Installation Kits	13
3.3.2	ONICON Standard Installation Hardware Kits	13
3.3.3	ONICON Hot Tap Installation Hardware Kits	13
3.3.4	Customer Supplied Installation Hardware	14
3.3.5	Confirming the Stack Height	15
3.4	Installing the Insertion Meter	16
3.4.1	Adjusting of the Meter Insertion Depth	17
3.5	Removal of the Insertion Meter	17
3.6	Inline Flow Meter Straight Run Requirements and Mechanical Installation	19
3.7	Wiring Connections	20
4.0	START-UP & COMMISSIONING	21
4.1	Helpful Hints for Start-up and Commissioning	21
4.2	Insertion Meter Start-up and Commissioning	22
4.3	Insertion Meter Start-up and Commissioning Worksheet	23
4.4	Inline Meter Start-up and Commissioning	24
4.5	Inline Meter Start-up and Commissioning Worksheet	25
4.6	Troubleshooting Guide	26
5.0	ANALOG ADJUSTMENT PROCEDURE	27
5.1	General Discussion	27
5.2	Analog Adjustment Procedure	27
5.2.1	Equipment Required	27
5.2.2	Procedure	28

APPENDIX

A	User Connections and Internal Wiring Diagrams
B	Installation Hardware Instructions
C	Insertion Turbine Assembly Detail Drawings
D	Conditions of Sale

SECTION 1.0: INTRODUCTION

We, at ONICON Incorporated, would like to thank you for purchasing our quality, U.S. made, Turbine Flow Meter. As our valued customer, our commitment to you is to provide fast reliable service and assistance, while continuing to offer you new products to meet your growing flow measurement needs.

1.1 PURPOSE OF THIS GUIDE

We have written this guide to provide the persons responsible for the installation, operation and maintenance of your turbine flow meter with the most specific equipment information they will need. This is NOT an electrical or plumbing trade manual.



WARNING

Please do not permit any persons to install, operate or maintain this equipment unless they have a complete knowledge of their trade skills and are competent to work on high pressure hot and cold water systems, according to their individual trades. Death or permanent injury may result from accidents with these systems.

This guide is the basic reference tool for all ONICON Turbine Flow Meters. If you have not purchased all of the options, there will be references in this manual which are not applicable to your meter(s).

1.2 TYPICAL TURBINE FLOW METERS

ONICON's Turbine Flow Meters measure the velocity of flowing liquids by counting the frequency at which the blades of a rotating turbine pass a fixed electrode. Circuitry within the flow meter electronics enclosure then converts the rotational rate to digital and/or analog signals which are transmitted via a connecting cable to any of ONICON's display devices, BTU meters and/or a data acquisition system.

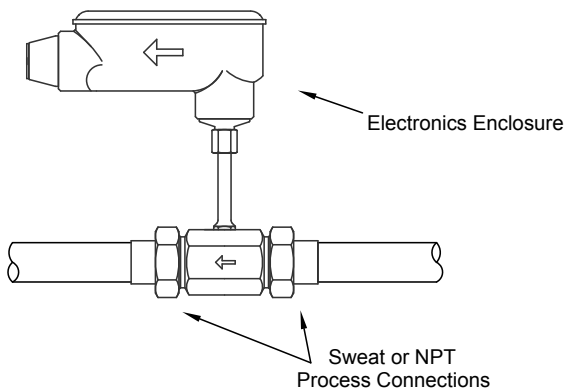

Inline Meter

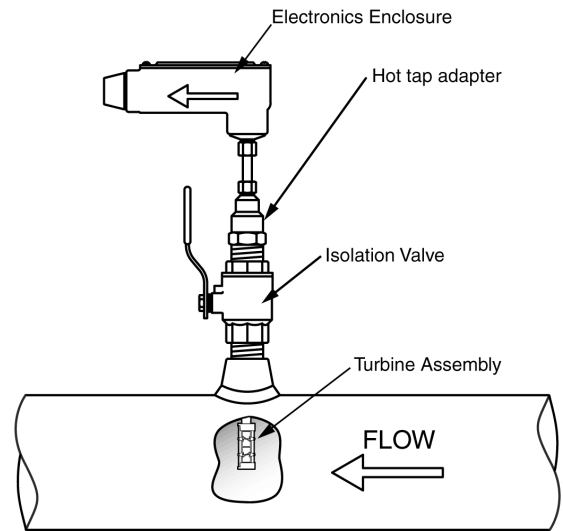

Insertion Meter

1.3 STANDARD FEATURES AND SPECIFICATIONS

(Refer to specification sheet for particular model to obtain additional details)

ACCURACY

F-1100 / F-1200 / FB-1200 Series

- ± 0.5% OF READING at calibrated velocity
- ± 1% OF READING from 3 to 30 ft/s (10:1 range)
- ± 2% OF READING from 0.4 to 20 ft/s (50:1 range)

F-1300 Series

- ± 0.5% OF READING at calibrated velocity
- ± 2% of reading from 0.8 to 38 GPM (50:1 range)

Sensing Method

F-1100 / F-1300 Series

Single turbine electronic impedance sensing (non-magnetic and non-photoelectric)

F-1200 / FB-1200 Series

Dual turbine electronic impedance sensing (non-magnetic and non-photoelectric) and frequency averaging circuitry.

Pipe Size Range

F-1100 Series

1¼" through 72" nominal

F-1200 / FB-1200 Series

2½" through 72" nominal

F-1300 Series

¾" or 1" NPT threaded or copper sweat process connections

Supply Voltage

24±4 V AC/DC at 50 mA

Liquid Temperature Range

Standard: 140° F continuous, 150° F peak

High Temp: 280° F continuous, 300° F peak

Insertion meters operating above 250° F require 316 stainless steel construction option

Ambient Temperature Range

-5 to 160° F (-20 to 70° C)

Operating Pressure

400 PSI maximum

Pressure Drop

F-1100 / F-1200 / FB-1200 Series

Less than 1 PSI at 20 ft/s in 2½" pipe, decreasing in larger pipes and lower velocities

F-1300 Series

3 PSI at maximum flow rate

Material

Wetted metal components

F-1100 / F-1200 / FB-1200 Series

Standard: Electroless nickel plated brass

Optional: 316 stainless steel

F-1300 Series

Brass sensor body

Electronics Enclosure

Standard: Weathertight aluminum enclosure (NEMA4)

Optional: Submersible enclosure (NEMA6)

Electrical Connections

Standard: 10' of PVC jacketed cable with ½" NPT conduit connection

Optional: Indoor DIN connector with 10' of plenum rated cable

Output Signal(s)

F-1100 / F-1200 / F-1300 Series

Standard: Calibrated frequency output (0-15 V pulse, 0-500 Hz)

Optional: Analog and digital outputs also available, based on model

FB-1200 Series

Standard: Calibrated frequency output (0-15 V pulse, 0-500 Hz), contact closure output to report flow direction

Optional: Analog and digital outputs also available, based on model

1.4 MODEL NUMBERING SYSTEM

		F(B)-XX YY
		↑ ↑
SERIES		OUTPUT SIGNAL
F-11	Single Turbine, Insertion Type	00 Frequency Output (15 V pulse) For connection to ONICON display or BTU meter only. Signal is too fast for most building control systems (0-500 Hz).
F-12	Dual Turbine, Insertion Type	10 Analog Output (non-isolated) Provides both 4-20 mA and 0-10 V outputs. Most commonly used output type. (3-wire connection)
FB-12	Bi-Directional, Insertion Type	11 Isolated Analog Output Provides both 4-20 mA and 0-10 V outputs. Signal ground is isolated from power supply and pipe ground. (4-wire connection)
F-13	Inline Turbine Meter	20 Divided Output (Solid state dry contact) Provides an isolated binary/digital output. Signal is divided to limit the maximum frequency. For rate/totalization.
		30 Scaled Output (Solid state dry contact) Provides an isolated binary/digital output scaled to provide one pulse per desired unit volume (e.g.: 1 pulse = 10 gal.). Ideal for totalization applications.

Example: “F-1210” = Dual turbine, analog output

1.5 ADDITIONAL REQUIRED HARDWARE

All ONICON insertion type meters can be installed and removed via a 1” or larger full port ball valve without stopping flow. The terms “Standard” and “Hot Tap” refer to the installation method of the isolation valve kit only.

Standard Installation Hardware: For new construction or scheduled shutdown; once kit is installed, the flow meter can be installed or removed without system shutdown.

Hot Tap Installation Hardware: For applications which require the access hole in the pipe to be drilled through the valve using a wet tap drilling machine, while the hydronic system is pressurized and operating.

NOTE: Installation hardware materials vary greatly based on pipe material, pipe size and standard vs. hot tap versions.

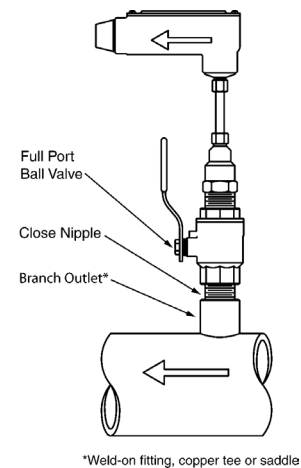

1.6 WARRANTY AND SERIAL NUMBER

Warranty

ONICON’s complete warranty is included in Appendix C of this manual as a part of the “Conditions of Sale.” Meters purchased after November 1, 2000 include a two-year “No fault” warranty which may cover accidental damage caused during installation or start up.

Serial Number

The serial number of your flow meter is located on a label on the side of the electronics enclosure. The model number is also listed on this label. The serial number is a unique identifier that you should refer to, along with the model number, whenever you contact ONICON for assistance regarding your meter.

SECTION 2.0: UNPACKING

Turbine flow meters are generally shipped in one package unless optional hardware or equipment is ordered. This package may contain up to two complete meters along with the optional installation kits. Any display equipment ordered with the meters, will be packed separately. Please open all packages with caution to avoid damaging to their contents. In the event that anything is damaged when you receive it, notify the shipping company immediately and the ONICON customer service department. Most products are shipped insured unless the customer specifically requests otherwise.

2.1 CHECKING THAT YOU HAVE RECEIVED EVERYTHING

The Documentation

Enclosed with each flow meter is a comprehensive documentation package which includes the following items:

- Installation and Operation Guide
- Flow Meter Calibration Certificate

Please notify the ONICON customer service department if any documents are missing.

The Flow Meter

The flow meter was carefully packed prior to shipment and should arrive without any damage. Prior to installation, inspect for physical damage such as broken turbine blades or a damaged stem.

- Test the turbine(s) to see that they rotate freely when you gently blow on them parallel to their shafts.
- Make sure that the threads on the insertion meter hot tap adapter have not been damaged.
- Inspect the insertion meter stem for bends or other damage. The stem forms the seal against liquid leakage as it slides through an 'O' ring inside the hot tap adapter. Deep scratches may cause leakage.
- The serial and model numbers on the laminated wiring connection /calibration data tag attached to the meter should match the numbers on the tag mounted directly on the flow meter. Be sure that the unit was calibrated to the correct pipe size and flow range.

SECTION 3.0: INSTALLATION, REMOVAL & ADJUSTMENT



WARNING

Insertion flow meters may often be installed in pipes which are under high pressure. Accidents with these systems can cause serious injury or death. Only persons experienced with high pressure systems and related knowledge in the heating, cooling and fluid metering fields should attempt to install adjust or remove the flow meter. Carefully read the installation and removal instructions in this manual before performing any work on these meters.

ONICON will be happy to assist with technical recommendations and to provide guidance by telephone or e-mail. On-site field engineering, installation and service is also available at additional cost.

3.1 INSTALLATION SITE SELECTION

Install the flow meter where it will be accessible for personnel to perform necessary periodic maintenance. The clearance required for insertion meter installations is typically 23”-36” from the pipe wall to the nearest obstruction above the valve assembly. This clearance dimension will increase with large diameter pipes. Allow at least 6” of clearance for inline meter installations. The environment should be free of corrosive liquids/fumes, temperature extremes and heavy vibration. The following information should be used as a guide to the proper location for installing the meter.

GENERAL PRACTICES:

1. For best results, install the flow meter in a straight run of pipe, free of bends, tees, valves, transitions, and obstructions.
2. Straight run requirements vary based on the nature of the upstream obstruction. Review the following pages for guidelines in determining minimum upstream straight run requirements based on the nature of the obstruction.

Note: Depending upon specific location details, more or less straight run may be required to produce a satisfactory flow profile.

3. If there is insufficient straight run, allow 80% of the run upstream and 20% of the run downstream. If the total length of straight run is less than 70% of the recommended length, performance may seriously degrade, and consideration should be given to changing to the series F-3000 In-line Electromagnetic Flow Meter.

How To Determine The Available Straight Pipe Diameters:

For each application, locate the longest straight, unobstructed section of pipe (no bends, tees, valves, other insertion probes, size transitions). The longest straight pipe run in inches divided by nominal pipe size in inches equals “diameters of straight pipe.” For closed loop applications, consider both the supply and return lines as possible locations.



IMPORTANT NOTE

Always use the maximum available straight run. When more than the minimum required straight run is available, place the meter such that the excess straight run is upstream of the meter location.

INSERTION AND INLINE FLOW METER SITE SELECTION GENERAL GUIDELINES (Shown with Insertion Meter)

- **Install in vertical or horizontal pipe.**
- For horizontal pipe position meter anywhere in upper 240°.

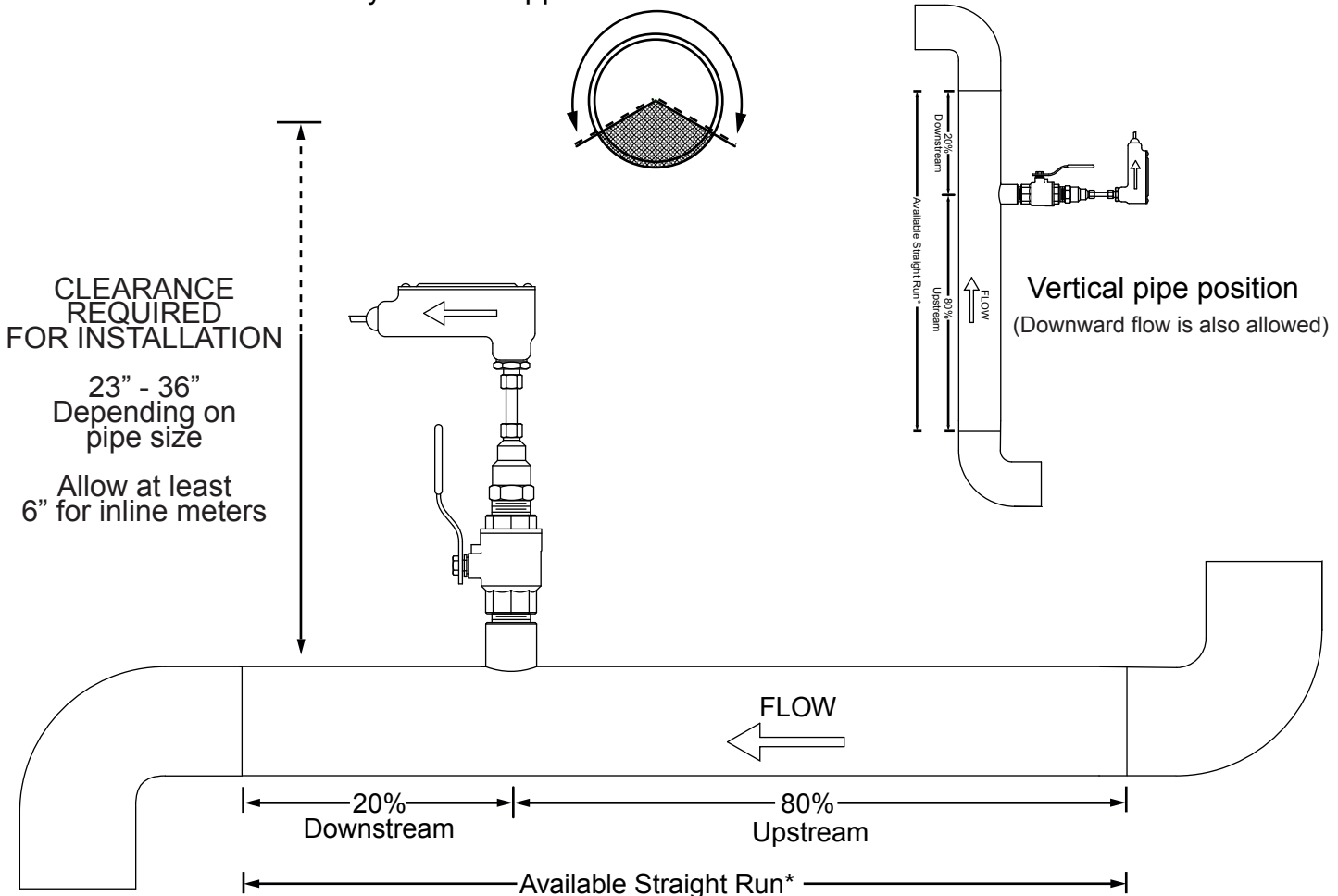

*See following pages for model specific straight run requirements.

EVALUATING UPSTREAM PIPING CONDITIONS

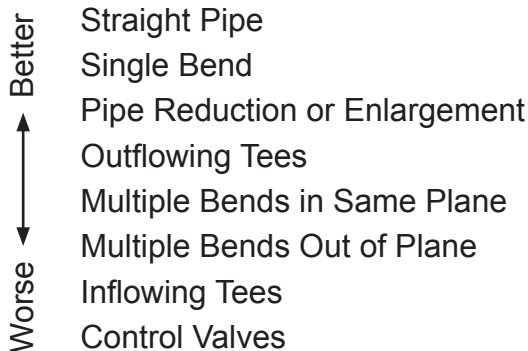

STRAIGHT RUN REQUIREMENTS FOR INSERTION TURBINE FLOW METERS

Series F-1100 Single Turbine Flow Meters

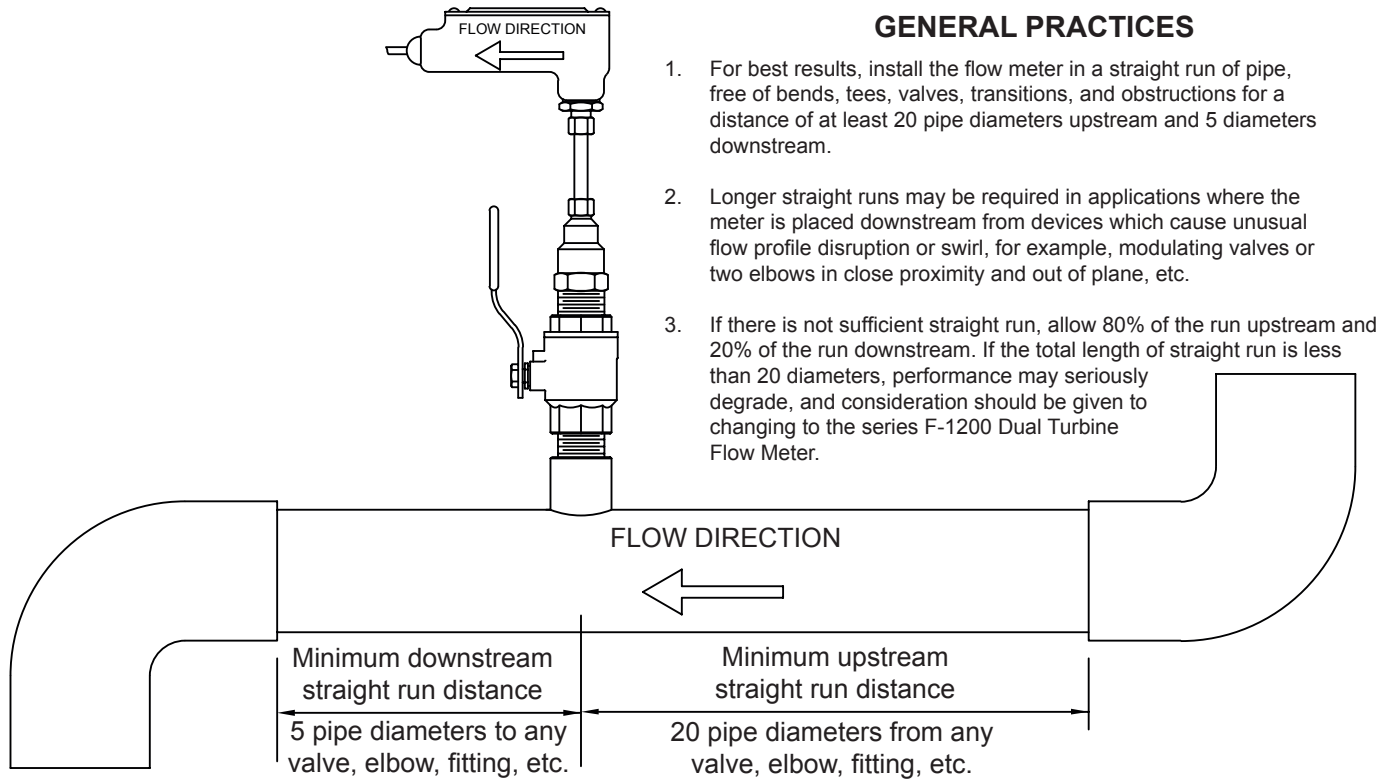

Series F-1200 Dual Turbine Flow Meters

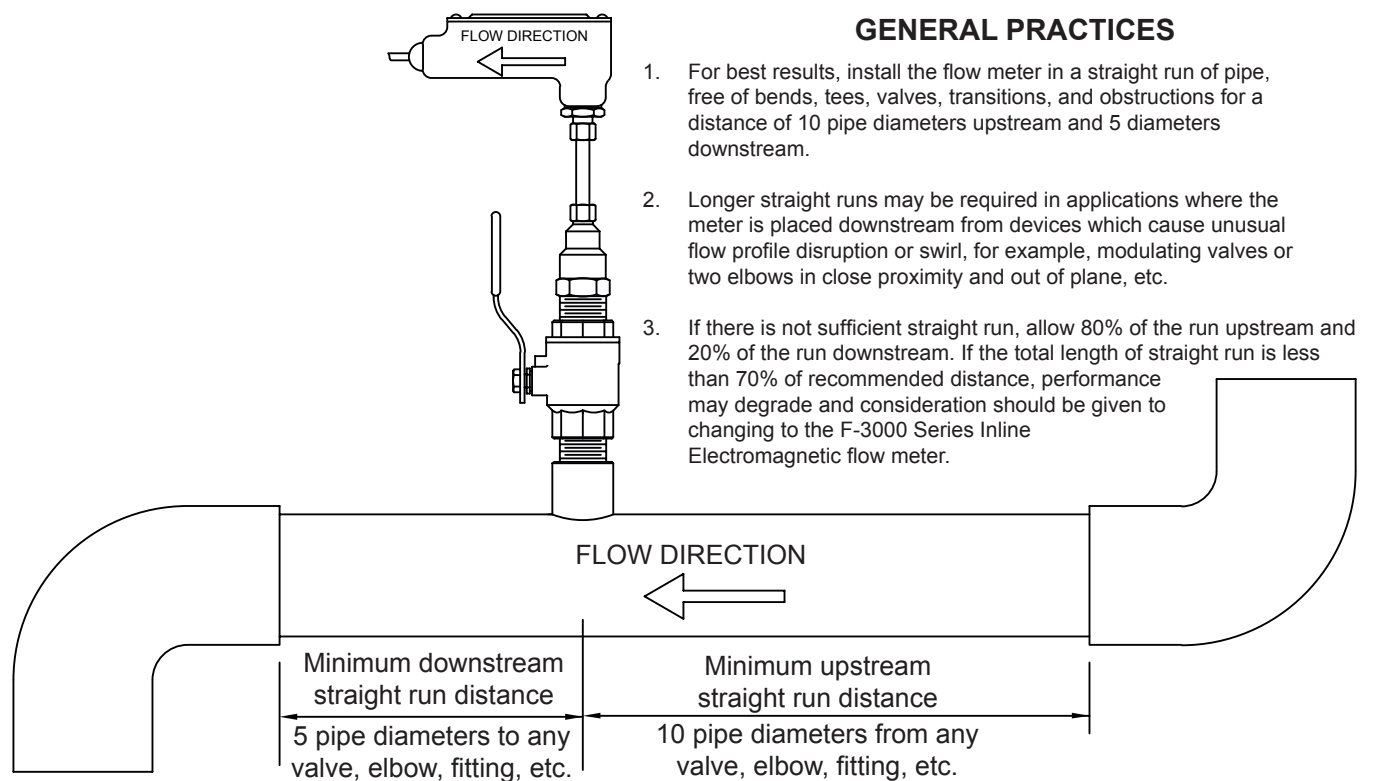

Series FB-1200 Dual Turbine Flow Meters

Bi-Directional Flow Applications

GENERAL PRACTICES

1. For best results, install the flow meter in a straight run of pipe, free of bends, tees, valves, transitions, and obstructions for a distance of at least 10 pipe diameters on each side of the flow meter.
2. Longer straight runs may be required in applications where the meter is placed downstream from devices which cause unusual flow profile disruption or swirl, for example, modulating valves or two elbows in close proximity and out of plane, etc.
3. If there is not sufficient straight run, allow 50% of the run up stream and 50% of the run downstream. If the total length of straight run is less than 70% of the recommended distance, performance may degrade and considerations should be given to changing to the F-3000 Series Inline Electromagnetic flow meter.

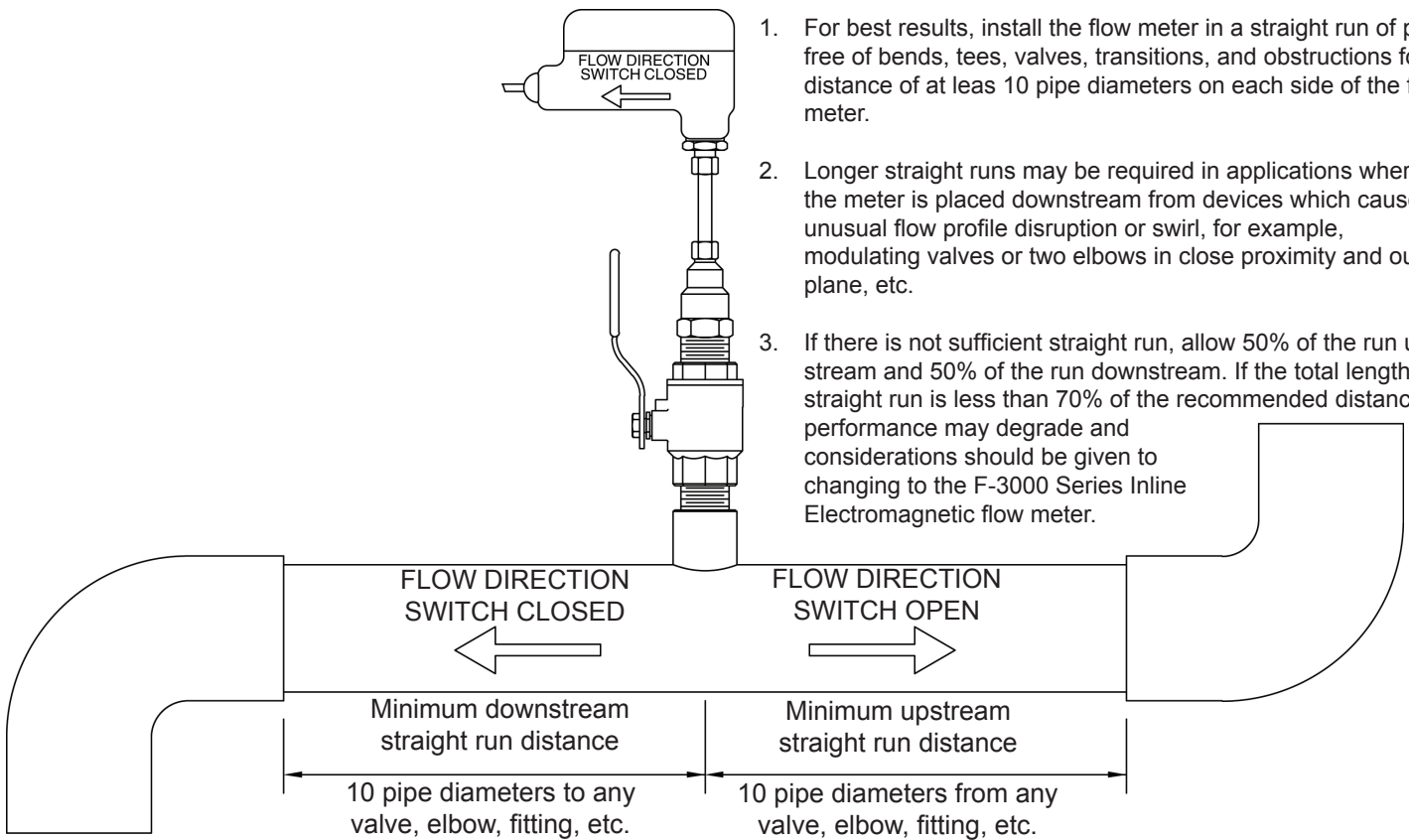

Insufficient Straight Run Guidelines for Bi-directional Flow Applications

If there is insufficient available straight run, allow 50% of the run upstream and 50% of the run downstream. If the total length of straight run is less than 20 diameters, performance may degrade and consideration should be given to changing to the F-3100 or F-3200 In-line Electromagnetic Flow Meters.

Some installations may work better with straight run optimized for flow in one direction. For example, with flow meters installed in the bypass line between de-coupled constant volume primary and variable secondary loops, it may be more important to accurately measure positive flow (from supply to return.) Negative flow measurements (from return to supply) are generally less critical, and it may be enough just to know that any negative flow is present. In this scenario, maximizing straight run for positive flow might be a preferred strategy.



IMPORTANT NOTE

Always use the maximum available straight run. When more than the minimum required straight run is available, place the meter such that the excess straight run is upstream of the meter location.

3.3 INSERTION METER MECHANICAL INSTALLATION

ONICON Insertion Turbine Flow Meters employ a hot tap adapter design that allows for insertion and removal, when necessary, without interrupting flow and draining the pipe. To take advantage of this feature, the flow meter must be installed through an isolation valve. The installation must also allow for sufficient overhead clearance to fully extract the meter, and a full 1" opening in the pipe wall is required to clear the sensor head and allow for insertion. Make sure that your valves and fittings are full port and at least 1" in actual internal diameter.

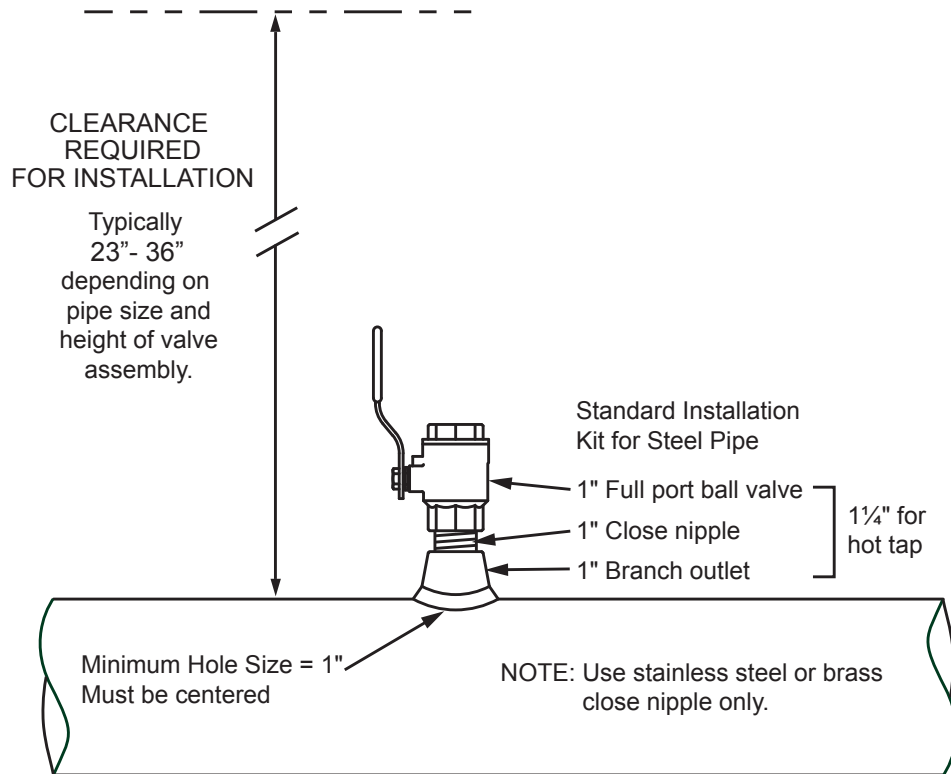

CAUTION



ONICON insertion style flow meters must be installed through a valve assembly. Failure to do so negates the ability to remove the meter without shutting down flow and draining the system. It will also result in an excessive amount of stem protruding from the pipe. Excessive stem lengths unnecessarily expose the meter to incidental damage.

IMPORTANT NOTE



Flow meters installed through oversized access holes will be subjected to undesirable turbulence that may affect the accuracy of the meter.

3.3.1 Insertion Meter Installation Kits

ONICON offers a wide range of installation hardware kits for commonly used pipe materials. The kits are specifically designed for ONICON insertion flow meters, and their use is recommended. Refer to Appendix B of detailed information regarding ONICON installation hardware kits.

The use of ONICON installation hardware kits accomplishes two important objectives. First, it ensures that the proper hardware is used. Second, it simplifies order processing by standardizing the dimensions of the installation hardware. ONICON must have an accurate measurement of the overall height of the installation hardware as measured from the outside wall of the pipe to the top of the valve in order to determine the correct stem length when assembling insertion meters in our factory. ONICON documents refer to this dimension as the stack height.

ONICON installation hardware kits consist of three separate component parts:

Some type of threaded branch outlet,



An interconnecting close nipple,

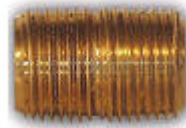

And a full port isolation valve.



Different pipe materials require different branch outlets and may include additional bushings to properly size the opening.



3.3.2 Onicon Standard Installation Hardware Kits

Standard installation hardware kits are designed to be installed on piping systems that are drained and at atmospheric pressure. The access hole is drilled (1" minimum) prior to installation of the branch outlet with 1" NPT threads, the close nipple and full port ball valve. Once the isolation valve is installed, the piping system can be flushed, filled and pressurized. The flow meter may now be inserted or removed by hand without having to stop flow or drain the system. Please read all instructions before proceeding with meter insertion.

3.3.3 Onicon Hot Tap Installation Hardware Kits

ONICON offers an alternative installation hardware kit when it is not practical to relieve pressure and drain the system. In this case, a 1¼" branch outlet, a close nipple and a 1¼" full port ball valve are installed first. Then, a hot tap drilling apparatus is used to drill a 1" diameter hole through the valve. This eliminates the need to stop flow and drain the pipe. Please read all instructions before proceeding with meter insertion.

3.3.4 Customer Supplied Installation Hardware

There are occasions where circumstances require that the customer provide the installation hardware or that the flow meter be installed through existing hardware. In these cases, it is important to confirm that the installation hardware is suitable for use with the flow meter provided by ONICON before it is installed. The installation must allow for sufficient overhead clearance to fully extract the meter and a full 1" opening in the pipe wall is required to clear the sensor head and allow for insertion. Make sure that your valves and fittings are full port and at least 1" in actual internal diameter.

Installation hardware generally consists of three separate component parts:

Some type of threaded branch outlet,



An interconnecting close nipple,



And a full port isolation valve.

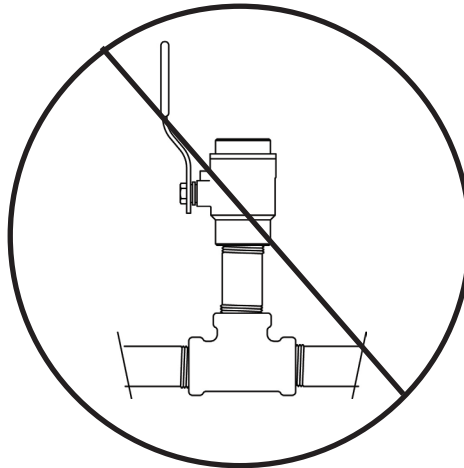

IMPORTANT NOTE

Do not use threaded steel or slip PVC tees to provide the 1" opening in the pipe. Tees of this type will cause significant errors in the flow measurement.



CAUTION

In order to provide the flow meter with the correct stem length, ONICON must know the overall height of the installation hardware as measured from the outside wall of the pipe to the top of the valve where the meter is installed.



CAUTION

Use stainless steel or brass nipple only.

3.3.5 Confirming the Stack Height

ONICON insertion flow meter stem lengths vary according to the pipe diameter and the height of the installation hardware stack. ONICON records the stack height dimension provided by the customer at the time of order entry, and the information is used to size the stem. This dimension is shown on the laminated insertion depth gage tag attached to the meter.

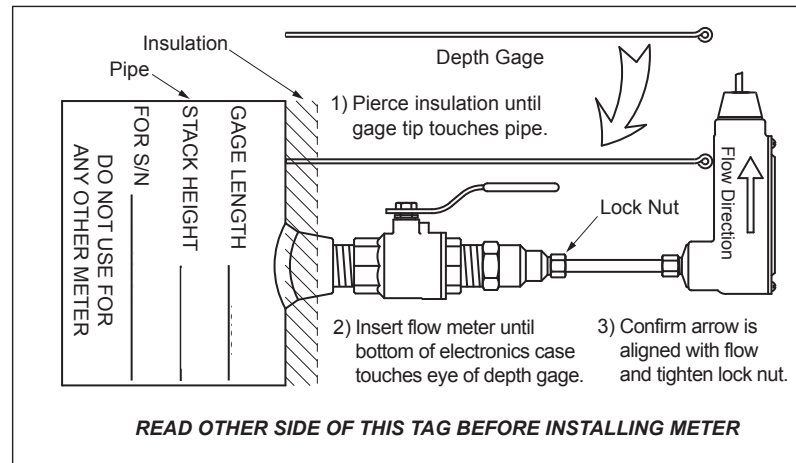

Prior to installing the meter, confirm that the stack height recorded on the tag is close to the actual stack height. Flow meter stems are intentionally over sized to allow for variations of at least 2" in the stack height. Contact ONICON prior to installation if there is any question regarding stack height or stem length. This will allow ONICON to offer you credit for your meter if you decide to exchange the meter for one with a different stem length. Returns may be subject to a restocking fee.

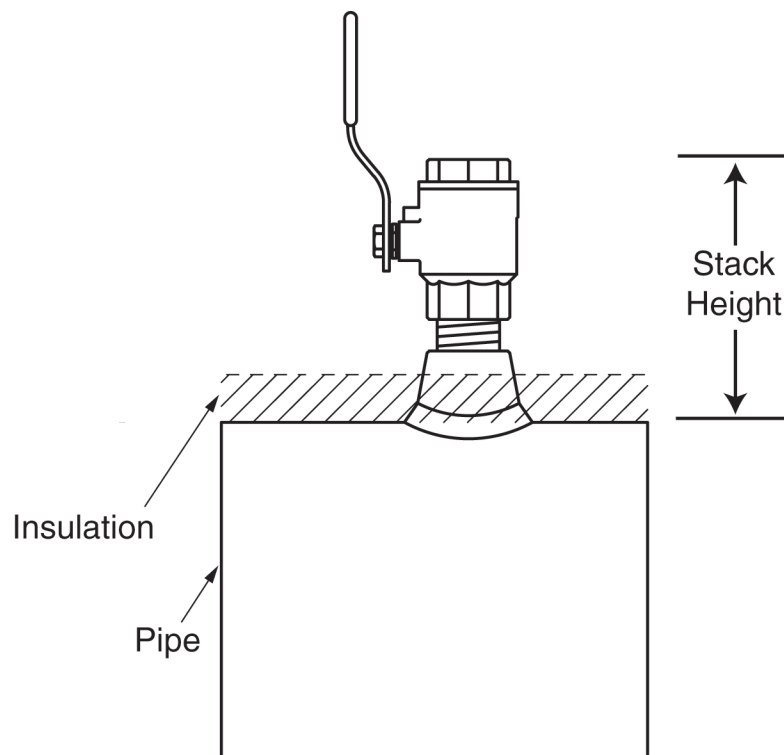

3.4 INSTALLING THE INSERTION METER



WARNING

SYSTEM MAY BE UNDER HIGH PRESSURE. When installing the meter, adjusting its position or removing the meter, be sure to hold the electronics enclosure firmly by hand before SLOWLY loosening the positioning clamping nut. Failure to do this will allow the pressure to suddenly and rapidly force the meter from the pipe causing serious injury. The meter could also be damaged or break apart causing a break in the water seal with the resultant loss of large amounts of water. The hand effort required to hold the meter will be 0.11 times the pipe pressure.

Begin by calculating the effort that will be required to hold the meter. Establish adequate footing for this task, taking extra caution when working from a ladder or platform. Use the following formula:

$$E=0.11 \times P$$

Where: **E** = effort in pounds

P = system pressure in pounds per square inch

Example: In a 300 PSI system, 33 pounds of effort is required to insert the meter into the pipe.

Installing the meter with a factory supplied depth gage:



WARNING

When you are ready to refill the system, make sure that all lines are filled with water before inserting the turbine assembly into the stream. If the lines are not filled, air may interrupt the flowing stream and damage the turbine assembly. A greater danger is that if this is a hot water system, some water may flash into steam and exceed the high temperature limit for the turbine and its mechanical assembly. This flash over could exceed the pressure ratings of the meter and the assembly could fail allowing steam and hot water to escape causing serious injury.

After fitting the necessary plumbing hardware, flush the entire system so that it is free of flux, solder and slag. Prepare to install the flow meter by loosening the clamping nut and withdrawing the turbine assembly fully into the hot tap adapter. Next, thread the adapter on to the ball valve using a paste type thread sealant. Do not use Teflon tape as torn strands of the tape may wind around the turbine, slowing down or even stopping the turbine.

Check the installation for leaks by slightly opening the ball valve. An 'O' ring in the adapter seals the meter stem against leakage. If there are any leaks around the clamping nut or stem, **DO NOT ATTEMPT TO STOP THE LEAKAGE BY OVERTIGHTENING THE CLAMPING NUT. Damage to this nut or the clamping ring under the nut may prevent the assembly from properly holding the meter in the pipe.** The clamping nut is not part of the sealing mechanism. Any leaks in this area indicate that the 'O' ring is not sealing properly and you must contact the factory for assistance.

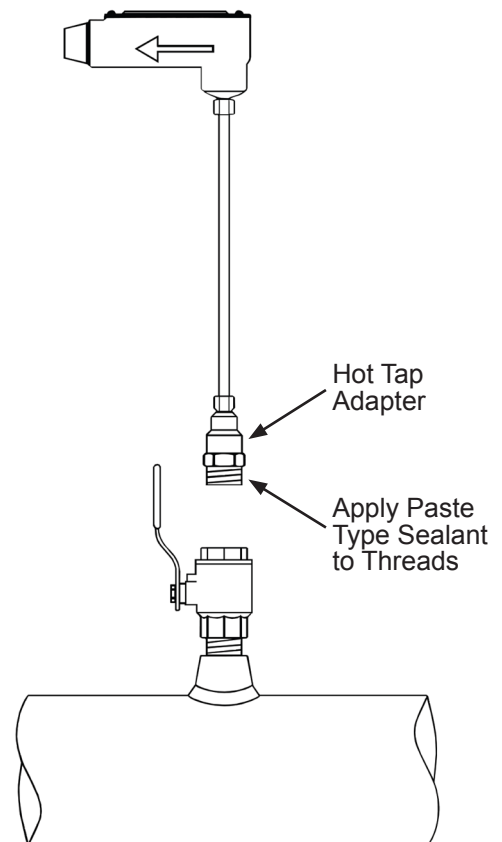

1. Open valve completely, loosen the position clamping nut, and insert the meter until the bottom of the electronics case touches the eye of the depth gage. (Pierce insulation with gage until the tip touches the pipe.)
2. Position the electronics enclosure parallel to the pipe in the proper direction relative to the flow. This will position the turbine with its axis in line with the flow and in the correct direction.
3. Tighten the position clamping nut. **Contact ONICON for assistance when installing a meter without a depth gage.**

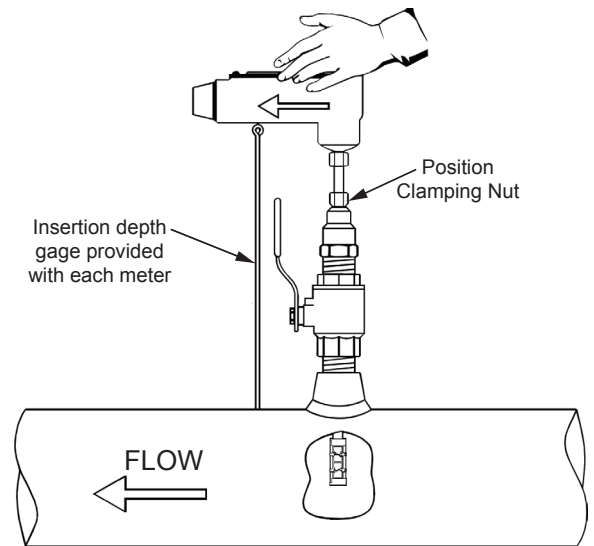

CAUTION

Do not release the flow meter until you have tightened the position clamping nut enough to hold the flow meter in the desired position. This will require less torque than you might think, so be careful not to overtighten it and risk damaging the adapter, nut or stem.

NOTE: For installations with a limited straight run of pipe (less than the recommended distances shown on pages 10 and 11), adjustments in insertion depth may be needed to compensate for velocity flow profile variations. Please contact the factory for information on velocity flow profiling for determining the average velocity location in undeveloped flow locations.

3.4.1 Adjustment of the Meter Insertion Depth



WARNING

If adjustment of the meter depth is required, the same procedure must be followed as if the meter were being removed. Please carefully read the section below on removal of the meter. Remember, the meter may be under high pressure and failure to follow the procedure may result in serious injury.

3.5 REMOVAL OF THE INSERTION METER



WARNING

Remember, the meter may be under high pressure. And while removal of the meter is basically the reverse of the insertion procedure detailed above, care must be taken to ensure that the meter is supported against the pipe pressure before the position clamping nut is loosened. Failure to do this will allow the pressure to suddenly and rapidly force the meter from the pipe causing serious injury.



WARNING

Prior to removal of the meter, make sure that you are standing on a secure platform and have both hands available to manipulate the flow meter.

First support the flow meter against the pipe pressure by holding the electronics enclosure firmly in hand BEFORE loosening the position clamping nut. The effort required is the same as that required for insertion of the meter and should be calculated according to the formula in section 3.4 covering insertion of the meter. This effort will be 0.11 times the pipe pressure. **If your footing is not secure, or if your ability to hold the meter is limited for any reason, DO NOT loosen the clamping nut.**

SLOWLY loosen the position clamping nut and **carefully and slowly** allow the pressure to force the meter out of the pipe. This is not at all difficult, but you must not let go of the meter until it is fully withdrawn into the hot tap adapter. Do not attempt to close the ball valve until you are certain that the turbine assembly is fully withdrawn into the hot tap adapter.

A common cause of damage to meters comes from accidentally closing the valve and crushing the turbine assembly. To avoid this, gently rotate the meter by swinging the electronics enclosure back and forth (twist the stem, do not bend it) while you slowly close the valve. If the valve touches any part of the meter, you will feel it as you are moving the meter. If the valve touches anything, it means the meter is not fully withdrawn. Usually a gentle twisting motion while withdrawing the meter will clear any obstruction and permit the meter to withdraw completely. (Excessive build-up on the stem may require the hot tap 'O' ring to be lubricated with silicone.)

Continue to hold the meter in place after the valve is completely closed to prevent the turbine assembly from slipping back into the valve body. Slowly unscrew the hot tap adapter from the valve. Once the adapter is loosened, allow pressure to vent from inside the hot tap adapter before removing it from the valve. There will be a small amount of water inside the hot tap adapter. A small container can be held under the valve to catch any spilled water. Once the meter has been moved to its new depth, tighten the position clamping nut. Next, place several turns of electrical tape around the stem just above the clamping nut so that at a later time, when the meter is removed for service, it can be easily replaced at the same depth.

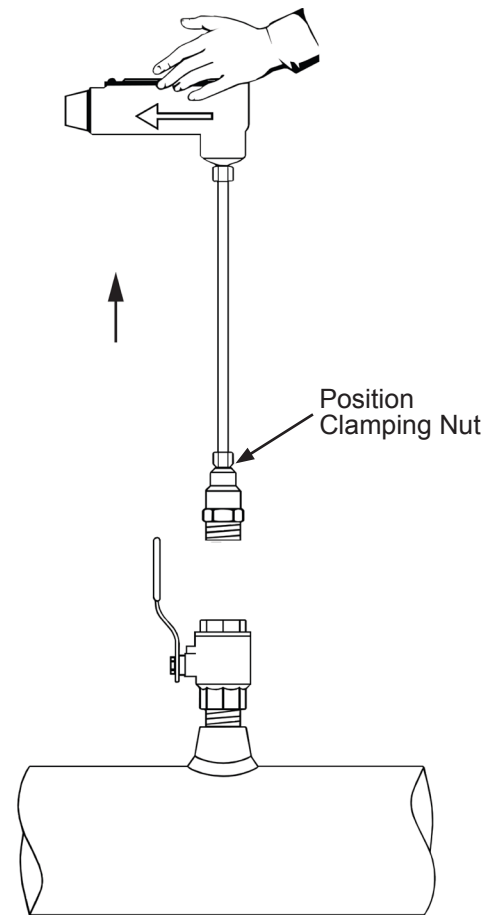

WARNING

In hot water systems, even a small amount of water can cause serious personal injury. Use extra caution when working with hot water meters.

3.6 INLINE METER STRAIGHT RUN REQUIREMENTS AND MECHANICAL INSTALLATION

Locating the meter

1. Install process connections (sweat or threaded end pieces) making certain to leave adequate straight unobstructed pipe runs upstream and downstream of the meter location.
 - a. The minimum upstream straight run should be at least 20 diameters and the downstream straight run should be at least 5 diameters in length.
 - b. If more than 25 diameters of straight run are available at the installation site the excess straight run should be upstream of the meter location.
 - c. Please note that ONICON strongly recommends the use of strainers upstream of the meter location.
 - d. ONICON also recommends the installation of isolation valves and a bypass loop to accommodate servicing the meter.

TYPICAL INLINE METER INSTALLATION

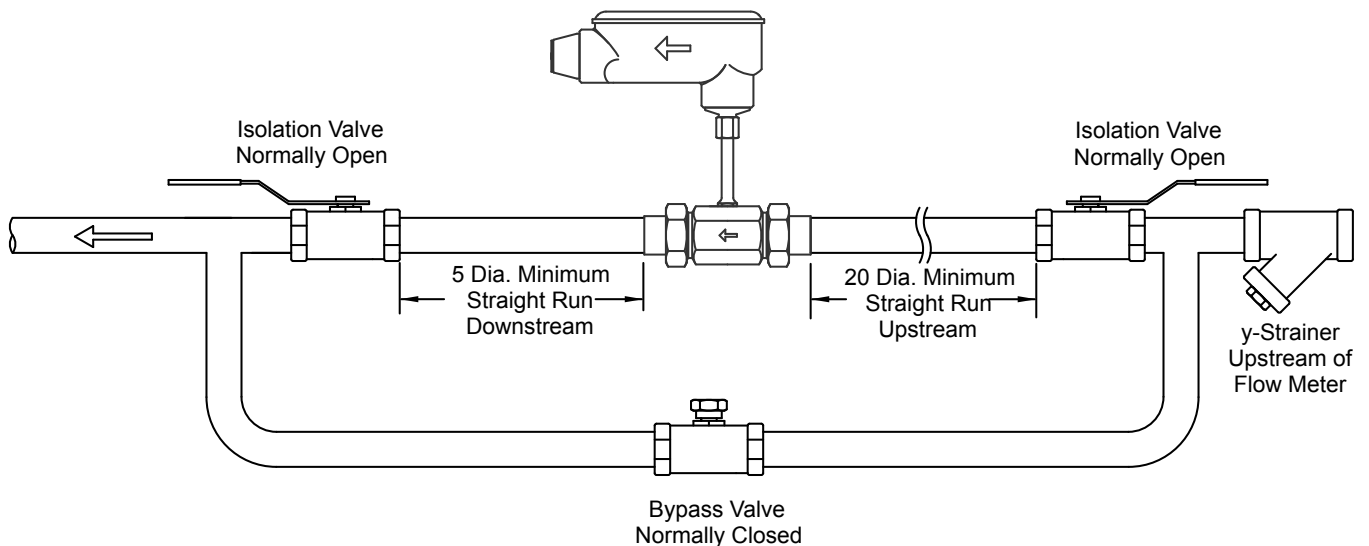

Installing the meter body

1. Make sure the unions are free of nicks or scratches on either end of the flow meter body and on the process connections.
2. Spray the union faces with a silicone spray or apply a thin coat of beeswax to enhance seating. Do not use paste thread sealant on union faces.
3. Recommended torques for union seal: 70 ft/lbs minimum
4. Make sure alignment of pipe does not put lateral stress on either joint.

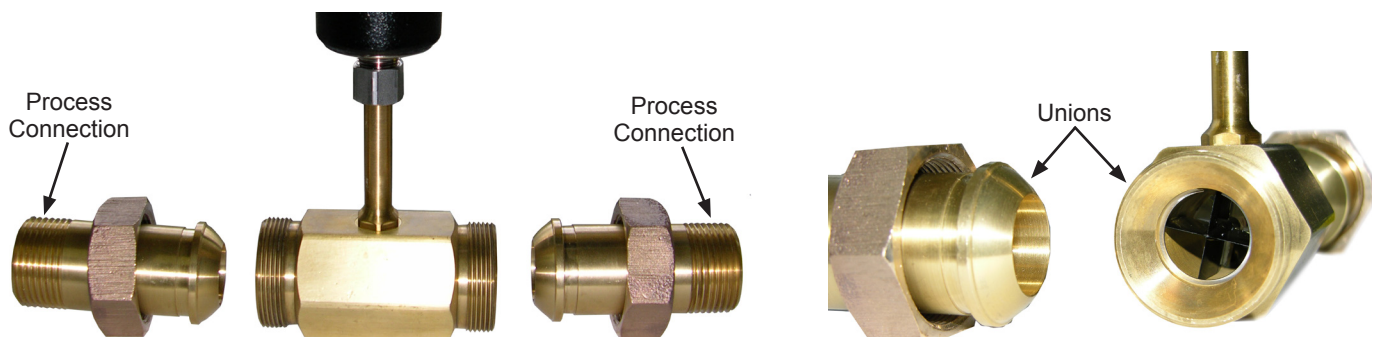

3.7 WIRING CONNECTIONS

Make connections to the 10' cable, which is supplied by ONICON and is pre-wired to the circuit board.



CAUTION

Do not attempt to make any connections inside the electronics enclosure, or to remove factory installed cable, strain relief or conduit fitting. Damage resulting from these actions will not be covered under warranty.

The most common cause of electronic failures are miswired connections. If you are adding additional cable, please record any substitution of wire colors. If additional cable is purchased from ONICON, the color code can be maintained. Cable from other sources will most likely have a different set of colors. Please refer to Appendix A for wiring diagrams and factory color codes.

Only qualified service personnel should make connections between the flow meter and the user's external equipment. Any misapplication of power and/or ground can result in improper operation or damage to the flow meter circuitry, and to any externally connected equipment.

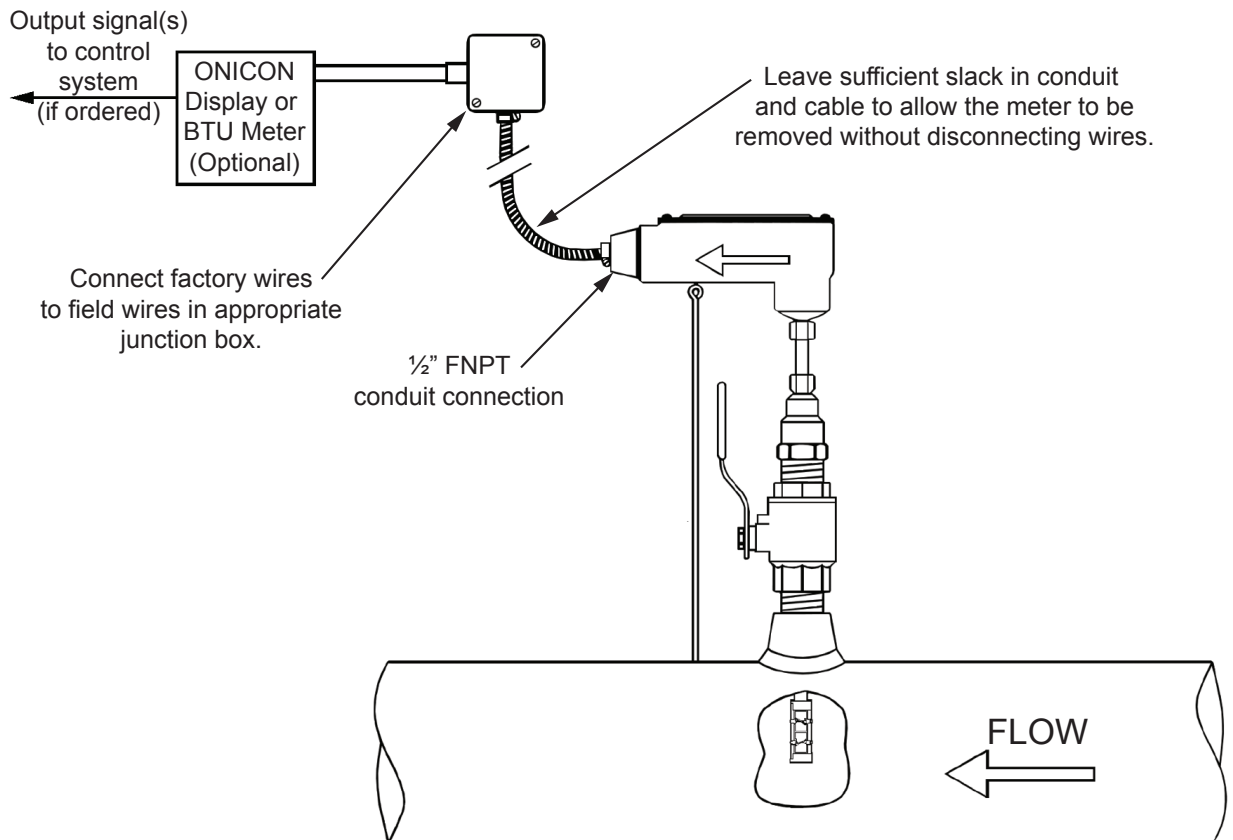

SECTION 4.0: STARTUP & COMMISSIONING FOR ONICON TURBINE FLOW METERS

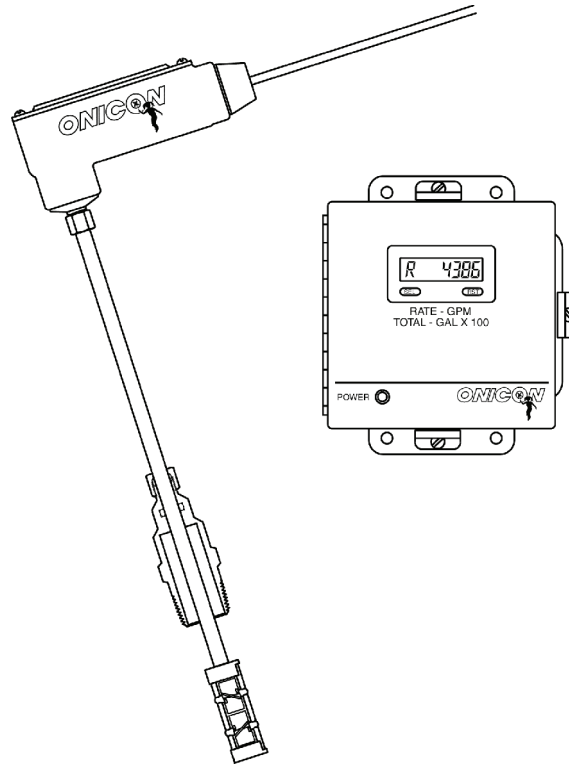

4.1 HELPFUL HINTS FOR START-UP AND COMMISSIONING

Step-by-step procedures and companion worksheets are located on the next four pages. Please read all installation instructions carefully before proceeding with start-up and commissioning.

Please read these helpful hints before proceeding with the start-up and commissioning procedure on the next page.

1. ONICON flow meters are individually calibrated for a particular application. Be sure to verify the pipe size and location.
2. The electronic sensing systems will not work in air. Blowing on the turbine(s) will not produce a signal. You can test the meter by holding the turbines under a faucet or carefully moving it back and forth in a bucket of water.
3. When measuring analog output signals, remember that current (mA) must be measured in series, while voltage is measured in parallel. If the 4-20 mA signal is already connected to a control system, you must break the connection and measure the signal in series.
4. When measuring frequency outputs in Hertz, take your multimeter out of “autorange mode” and manually set the range for a voltage level above 15 VDC. This will prevent false readings when no turbine signal is present.
5. All wiring connections should be made at the end of the factory cable. Do not attempt to remove the factory installed cable or change the orientation of the electronics enclosure.
6. Never connect power to analog or frequency output signal wires. ONICON turbine flow meters are not “loop-powered” devices.
7. Allow up to 45 seconds for signals to stabilize following power up.

4.2 INSERTION METER START-UP AND COMMISSIONING

Please read the entire procedure carefully before proceeding. Wiring diagrams are located in the appendix A. A worksheet for checking off the following steps and recording measured values is located on the following page.

1	Confirm meter location and adequate straight pipe run to achieve desired results.	Is the meter located in the correct location as required by the plans? Compare actual straight pipe upstream and downstream of the meter location to recommended distances identified in the installation manual. Note that the manual is very conservative, assuming worst-case pipe obstructions. Contact ONICON to discuss specifics of your application. If straight pipe run is very short, consult factory PRIOR to installing a single turbine meter to discuss possibility of upgrade to a dual turbine meter.
2	Confirm pipe size.	Confirm that the meter is tagged for the pipe size in which it is installed. When in doubt, measure the circumference of the pipe. Pipe O.D. = (circumference / 3.14) – (insulation thickness x 2)
3	Confirm insertion depth and orientation.	Each flow meter comes with an attached insertion gage and instruction tag. Ensure the meter is inserted to the correct depth and that the electronics enclosure is parallel with the pipe, with the arrow in the direction of flow.
4	Confirm control system programming.	Confirm that the control system input point is properly configured for the analog range (or digital pulse factor) identified on the flow meter calibration tag & certificate
5	Confirm connection to correct ONICON display or BTU Meter (if ordered).	Confirm that the flow meter serial number matches the ONICON display or BTU meter serial number (when ordered together).
6	Verify wiring before connecting power.	Prior to connecting the power, verify that the wiring is correct as shown in this manual (and/or with the additional wiring diagram provided with ONICON display or BTU meter.) If in doubt, call ONICON for assistance before proceeding further.
7	Confirm correct supply voltage.	Verify that 24 (+/- 4) V is available. Serial Numbers 115692 and later can accept 24 V DC or AC, but earlier meters required 24 VDC. Note: ONICON display module or BTU meter provide 24 VDC to the flow meter. ONICON display modules and BTU meters are typically powered by 120 VAC; however, low voltage versions are also available.
8	Connect power.	Wait approximately 45 seconds after power-on before proceeding further.
The following steps require flow in the pipe. Flow signal readings should be taken while holding the flow rate constant if possible; otherwise, take the various output readings as quickly as possible.		
9	Measure and record frequency output(s):	The average frequency output signal is a 0-15 VDC pulsed output ranging up to 500 Hz and must be measured with a frequency counter or oscilloscope. Measure DC frequency (Hz) from GREEN(+) to BLACK(-). Also measure DC volts on same wires. Five to seven VDC is normal for a spinning turbine, 0 or 14+ VDC indicates a stopped turbine. (A reading of 1 to 4 VDC could indicate a problem) $\text{GPM} = \frac{\text{Frequency in Hz} \times 60}{\text{Meter Factor in ppg}}$ (refer to calibration tag for meter factor) For dual turbine models, also measure and record the top and bottom turbine signals. TOP: WHITE(+) to BLACK(-) BOTTOM: ORANGE(+) to BLACK(-)
10	Measure and record analog or digital outputs. Current Output: Voltage (0-10V) Output: Divided Output: Scaled Output:	Refer to flow meter wiring diagram for wire colors for the various outputs available based on your particular flow meter model. Use the following formulas to calculate flow rate from measured analog signals: $\text{GPM} = \frac{(\text{measured current in mA} - 4) \times \text{Full Scale Analog Flow Rate}}{16}$ $\text{GPM} = \frac{\text{measured DC volts} \times \text{Full Scale Analog Flow Rate}}{10}$ Same calculation as step 9, except use “divided meter factor” (measure and record frequency) Each contact closure = unit volume identified as “Scale Factor” (measure and record time interval between contact closures.)
11	Compare various output signals to each other and to the flow rate displayed by the control system.	The top and bottom turbine frequencies (dual) should ideally be within about 20% of each other and their average should equal the average frequency output. Compare the flow rates calculated in STEPS 9 and 10 to each other and to the flow rate indicated by the control system. Refer to troubleshooting guide when readings are inconsistent.
End of standard start-up and commissioning. Please contact ONICON at (727) 447-6140 with any questions.		

4.3 INSERTION METER START-UP AND COMMISSIONING WORKSHEET

Please read all installation instructions carefully prior to proceeding with these steps. Wiring diagrams are located in the appendix. Use the following worksheet for checking off the commissioning steps and recording measured values:

STEP	TEST / MEASUREMENT	S/N: _____	S/N: _____	S/N: _____	S/N: _____
1	Meter location				
2	Confirm pipe size				
3	Insertion depth and orientation				
4	Control system programming				
5	Match display or BTU meter serial# (if ordered)				
6	Signal connections verified				
7	Supply voltage verified				
8	Connect power				
The following steps require flow in the pipe. Flow signal readings should be taken while holding the flow rate constant if possible; otherwise, take the various output readings as quickly as possible.					
9	Frequency output(s): Avg = green, Top = white Bottom = orange				
	Avg Freq. (HZ): _____ Hz	_____ Hz	_____ Hz	_____ Hz	_____ Hz
	Avg Freq. (VDC): _____ VDC	_____ VDC	_____ VDC	_____ VDC	_____ VDC
	Top Turbine (HZ): _____ Hz	_____ Hz	_____ Hz	_____ Hz	_____ Hz
	Top Turbine (VDC): _____ VDC	_____ VDC	_____ VDC	_____ VDC	_____ VDC
	Bottom Turbine (HZ): _____ Hz	_____ Hz	_____ Hz	_____ Hz	_____ Hz
	Bottom Turbine (VDC): _____ VDC	_____ VDC	_____ VDC	_____ VDC	_____ VDC
	Calculated Flow Rate: _____ GPM	_____ GPM	_____ GPM	_____ GPM	_____ GPM
10	Analog or digital outputs				
	4-20 mA signal: _____ MA	_____ MA	_____ MA	_____ MA	_____ MA
	0-10 V signal: _____ VDC	_____ VDC	_____ VDC	_____ VDC	_____ VDC
	Scaled output time interval or divided output frequency	_____	_____	_____	_____
	Calculated Flow Rate: _____ GPM	_____ GPM	_____ GPM	_____ GPM	_____ GPM
11	Flow rate displayed by control system	_____ GPM	_____ GPM	_____ GPM	_____ GPM

4.4 INLINE METER START-UP AND COMMISSIONING

Please read the entire procedure carefully before proceeding. Wiring diagrams are located in the appendix. A worksheet for checking off the following steps and recording measured values is located on the following pages.

1	Confirm meter location and adequate straight pipe run to achieve desired results.	Is the meter located in the correct location as required by the plans? Compare actual straight pipe upstream and downstream of the meter location to recommended distances identified in the installation manual. If straight pipe run is very short, consult ONICON PRIOR to installing the meter.
2	Confirm control system programming.	Confirm that the control system input point is properly configured for the analog range (or digital pulse factor) identified on the flow meter calibration tag & certificate
3	Confirm connection to correct ONICON display or BTU Meter (if ordered).	Confirm that the flow meter serial number matches the ONICON display or BTU meter serial number (when ordered together).
4	Verify wiring before connecting power.	Prior to connecting the power, verify that the wiring is correct as shown in this manual (and/or with the additional wiring diagram provided with ONICON display or BTU meter.) If in doubt, call ONICON for assistance before proceeding further.
5	Confirm correct supply voltage.	Verify that 24 (+/- 4) V is available. Serial Numbers 115692 and later can accept 24 V DC or AC, but earlier meters required 24 VDC. Note: ONICON display module or BTU meter provide 24 VDC to the flow meter. ONICON display modules and BTU meters are typically powered by 120 VAC; however, low voltage versions are also available.
6	Connect power.	Wait approximately 45 seconds after power-on before proceeding further.
The following steps require flow in the pipe. Flow signal readings should be taken while holding the flow rate constant if possible; otherwise, take the various output readings as quickly as possible.		
7	Measure and record frequency output(s):	The frequency output signal is a 0-15 VDC pulsed output ranging up to 500 Hz and must be measured with a frequency counter or oscilloscope. Measure DC frequency (Hz) from GREEN(+) to BLACK(-). Also measure DC volts on same wires. Five to seven VDC is normal for a spinning turbine, 0 or 14+ VDC indicates a stopped turbine. (1 to 4 VDC could indicate a problem) $\text{GPM} = \frac{\text{Frequency in Hz} \times 60}{\text{Meter Factor in ppg}} \quad (\text{refer to calibration tag for meter factor})$
8	Measure and record analog or digital outputs. Current Output: Voltage Output: Divided Output: Scaled Output:	Refer to flow meter wiring diagram for wire colors for the various outputs available based on your particular flow meter model. Use the following formulas to calculate flow rate from measured analog signals: $\text{GPM} = \frac{(\text{measured current in mA} - 4)}{16} \times \text{Full Scale Analog Flow Rate}$ $\text{GPM} = \frac{\text{measured DC volts}}{10} \times \text{Full Scale Analog Flow Rate}$ Same calculation as step 9, except use "divided meter factor" (measure and record frequency) Each contact closure = unit volume identified as "Scale Factor" (measure and record time interval between contact closures.)
9	Compare various output signals to each other and to the flow rate displayed by the control system.	Compare the flow rates calculated in STEPS 7 and 8 to each other and to the flow rate indicated by the control system. Refer to troubleshooting guide when readings are inconsistent.
End of standard start-up and commissioning. Please contact ONICON at (727) 447-6140 with any questions.		

4.5 INLINE METER START-UP AND COMMISSIONING WORKSHEET

Please read all installation instructions carefully prior to proceeding with these steps. Wiring diagrams are located in the appendix. Use the following worksheet for checking off the commissioning steps and recording measured values:

STEP	TEST / MEASUREMENT	S/N: _____	S/N: _____	S/N: _____	S/N: _____
1	Meter location				
2	Control system programming				
3	Match display or BTU meter serial# (if ordered)				
4	Signal connections verified				
5	Supply voltage verified				
6	Connect power				
The following steps require flow in the pipe. Flow signal readings should be taken while holding the flow rate constant if possible; otherwise, take the various output readings as quickly as possible.					
7	Frequency output(s): <small>Avg = green, Top = white Bottom = orange</small>				
	Avg Freq. (HZ):	_____ Hz	_____ Hz	_____ Hz	_____ Hz
	Avg Freq. (VDC):	_____ VDC	_____ VDC	_____ VDC	_____ VDC
	Calculated Flow Rate:	_____ GPM	_____ GPM	_____ GPM	_____ GPM
8	Analog or digital outputs				
	4-20 mA signal:	_____ MA	_____ MA	_____ MA	_____ MA
	0-10 V signal:	_____ VDC	_____ VDC	_____ VDC	_____ VDC
	Scaled output time interval or divided output frequency	_____	_____	_____	_____
	Calculated Flow Rate:	_____ GPM	_____ GPM	_____ GPM	_____ GPM
9	Flow rate displayed by control system	_____ GPM	_____ GPM	_____ GPM	_____ GPM

4.6 TROUBLESHOOTING GUIDE

NOTE: Also refer to the START-UP and COMMISSIONING GUIDE located on the preceding pages.

REPORTED PROBLEM	POSSIBLE SOLUTIONS
No signal	Verify that meter is inserted correctly into the pipe. <ul style="list-style-type: none"> • Verify that the electronics enclosure is parallel with the pipe. • Verify 24 V supply voltage. • Verify correct wiring to control system (see wiring diagram). • Check turbine(s) for debris.
Reading is too high or too low	<ul style="list-style-type: none"> • Confirm that there is adequate straight pipe run upstream of the meter. Verify pipe size. Contact factory if pipe size is different from calibration tag. • Verify that meter is inserted correctly into the pipe. • Verify that the electronics enclosure is parallel with the pipe. • Verify correct wiring to control system (see wiring diagram). • Confirm that output signals agree with each other (frequency vs. analog, etc.) • Confirm that control system is programmed for correct flow range or scale factor. • Check turbine(s) for debris.
Analog signal seems high or low and does not correspond to frequency output	Check for ground loop or offset voltage: <ul style="list-style-type: none"> • Disconnect analog signal input to control system and measure analog outputs directly from the flow meter. • Re-connect signal input to control system and measure the analog signals again. • Any difference between these readings indicates a potential ground loop or offset voltage. • Please contact ONICON for further assistance.
Control system displays flow rate, but no flow rate indication on local display module or BTU Meter	<ul style="list-style-type: none"> • Verify that all wires from flow meter were connected to the display module or BTU meter. • The frequency output wire (green) must be connected for any ONICON display or BTU meter.

For technical assistance, contact ONICON at (727) 447-6140.

SECTION 5.0: ANALOG ADJUSTMENT PROCEDURE

ONICON electronic circuits are designed and tested to ensure long life with minimal drift. It should not be necessary to make field adjustments or calibrations. It may, however, be necessary to rescale the analog output under the following conditions:

- The turbine was replaced with a new one that has a significantly different meter factor.
- It is necessary change the full scale flow rate for the analog output.
- An analog output meter is being moved to a different size pipe.

ONICON will clean, test and recalibrate the meter for a small fee. One or two day turnaround service is available when required. The information in this section is provided only for those instances where you cannot return the meter service and factory calibration. ONICON will provide assistance when performing this procedure via the telephone, if necessary.

While these adjustments are not complicated, they are crucial to the accuracy of the flow meter. Adjustments should only be made by qualified personnel having an understanding of flow equations and experience with control systems.

5.1 GENERAL DISCUSSION

ONICON insertion turbine flow meters measure the velocity of the fluid flowing in the pipe. Proprietary electronic impedance sensing circuitry detects the rotation of a freely spinning axial turbine, which is immersed in the flow stream. As each turbine blade passes a fixed electrode, an electronic pulse is produced by the circuitry. In the case of single turbine meters, the pulse rate is then calibrated in terms of the number of pulses per gallon for whatever size pipe the user has selected. This number is referred to as the METER FACTOR. For example an insertion flow meter might have a meter factor of 31.3 PPG (Pulses per Gallon) in 3" pipe. The meter factor is the calibration factor used to define the calibrated frequency output signal provided by all ONICON turbine meters. This frequency output signal can be used directly by some data acquisition systems. Other systems will require additional signal conditioning. In those cases, ONICON uses this signal to drive our analog and digital outputs.

Dual turbine meters provide the same calibrated frequency output except that the pulse rates from the upper and lower turbines are electronically averaged and the calibration is done using this average output signal.

5.2 ANALOG ADJUSTMENT PROCEDURE

This procedure adjusts both 4-20 mA & 0-10 V output signals. It is limited to meters with serial numbers 115692 and higher. Contact ONICON for assistance if your meter's serial number is below 115692.

5.2.1 Equipment Required

- **Multimeter: Capable of measuring voltage and current (mA)**
(4½ digit true RMS meter recommended)
- **Pulse Generator: 0-15 volt square pulse (0-10 volt minimum)**
0-500Hz minimum operating range
Recommended resolution 0.01Hz (0.1 Hz minimum)
- **Power Supply: 24 VAC or VDC ±4V**

5.2.2 Procedure

1. Determine the input frequency required to simulate the desired maximum flow rate using the equation below:

Where:
 F = Input Frequency (Hz)
 R = Maximum Flow Rate
 MF = Meter Factor*

*The meter factor is written on a calibration tag attached to each meter and is also recorded on the calibration data sheet. Use one of the three formulas provided based on the engineering units for the meter factor. Please contact ONICON if you cannot locate the meter factor, or if you wish to use the meter in a different pipe size.

For GPM	For l/s	For M3/hr
MF in pulses per gallon (ppg)	MF in pulses per liter (ppl)	MF in pulses per meter ³ (ppm ³)
$F = \frac{R \times MF}{60}$	$F = R \times MF$	$F = \frac{R \times MF}{3600}$

2. Remove the flow meter from the pipe and make sure the electrode and the surrounding area are dry.
3. Choose the input frequency range (Hz) from the table on the next page and set the appropriate range selection jumper. Refer to Appendix A for the internal wiring diagram of your model.
4. Connect the pulse generator output lead to the test signal input lead on the analog card, and connect the pulse generator ground lead to the black ground wire in the flow meter cable. Set the output to a 15 V P-P square wave at the frequency determined in step #1.
5. Set the DC voltmeter to the 0-10 V scale and connect the (+) lead to the brown wire in the flow meter cable. Connect the (-) lead from the voltmeter to the black ground wire in the flow meter cable.
6. Connect the red and black wires in the flow meter cable to the (+) and (-) terminals of the 24 V power supply respectively. Apply power.
7. Adjust the span potentiometer on the analog card to produce a 10 V reading on the voltmeter.

NOTE: The frequency ranges in the table below are a starting point, and since they vary with electronic component tolerance, it may be necessary to change the jumper position once rescaling is started. If the range of adjustment of the span potentiometer is not sufficient to produce the desired 10 VDC, change the jumper position as follows:

VOLTAGE READING TOO HIGH: Choose the next lower jumper position.

VOLTAGE READING TOO LOW: Choose the next higher jumper position.

8. The flow meter is now rescaled. Disconnect all equipment, replace the cover and reinstall the flow meter.

Analog Range Jumper Settings		
INPUT FREQUENCY (Hz) AT MAXIMUM FLOW RATE	SWITCH POSITION SINGLE/DUAL TURBINE	
Over 248	Hz	1
124 – 248	Hz	2
62 – 123	Hz	3
31 – 61	Hz	4
15 – 30	Hz	5
Under 15	Hz	6

APPENDIX A

User Connections and Internal Wiring Diagrams

FLOW METER WIRING INFORMATION

User Connections for Models with Frequency Output

Models: F-1100, F-1200, FB-1200 & F-1300



				Wiring Information		
F-1100 Single Turbine	F-1300 Inline	F-1200 Dual Turbine	FB-1200 Bi-Directional	WIRE COLOR CODE		NOTES
√	√	√	√	RED*	(+) 24 ± 4 V AC/DC supply voltage	Connect to power supply positive
√	√	√	√	BLACK	(-) Common ground (Common with pipe ground)	Connect to power supply negative
√	√	√	√	GREEN	(+) Frequency output signal: 0-15 V peak pulse	Output frequency is typically below 200 Hz, but can be up to 300 Hz
			√	GRAY	Dry contact directional output - indicates flow direction	Contact closed when flow is in direction of arrow on meter
			√	VIOLET		
DIAGNOSTIC SIGNALS						
		√	√	ORANGE	Bottom turbine frequency	These signals are for diagnostic purposes - connect to local display or BTU meter
		√	√	WHITE	Top turbine frequency	

F-1100 / F-1200 / F-1300 Wiring Diagram

Flow Meter Connections to ONICON Display or BTU Meter

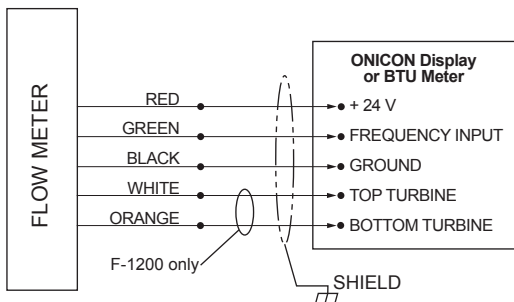

FB-1200 Wiring Diagram

Connections to ONICON Display or BTU Meter

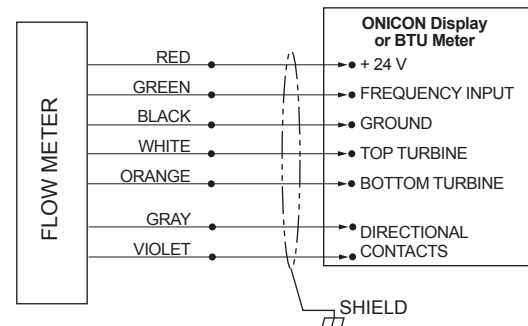

- NOTES:
- * 1. Serial Numbers 115691 and earlier require 24 VDC. Serial Numbers 115692 and higher can accept 24 V AC/DC.
 2. Black wire is common with the pipe (typically earth ground).
 3. For ONICON display module or BTU meter, connect all wires provided. Refer to wiring diagram provided with display or BTU meter.

WIRING DIAGRAM
INTERNAL CONNECTIONS FOR FREQUENCY
OUTPUT FLOW METERS
MODELS F-1100 / F-1200 / F-1300
 For use with serial numbers 115692 and later

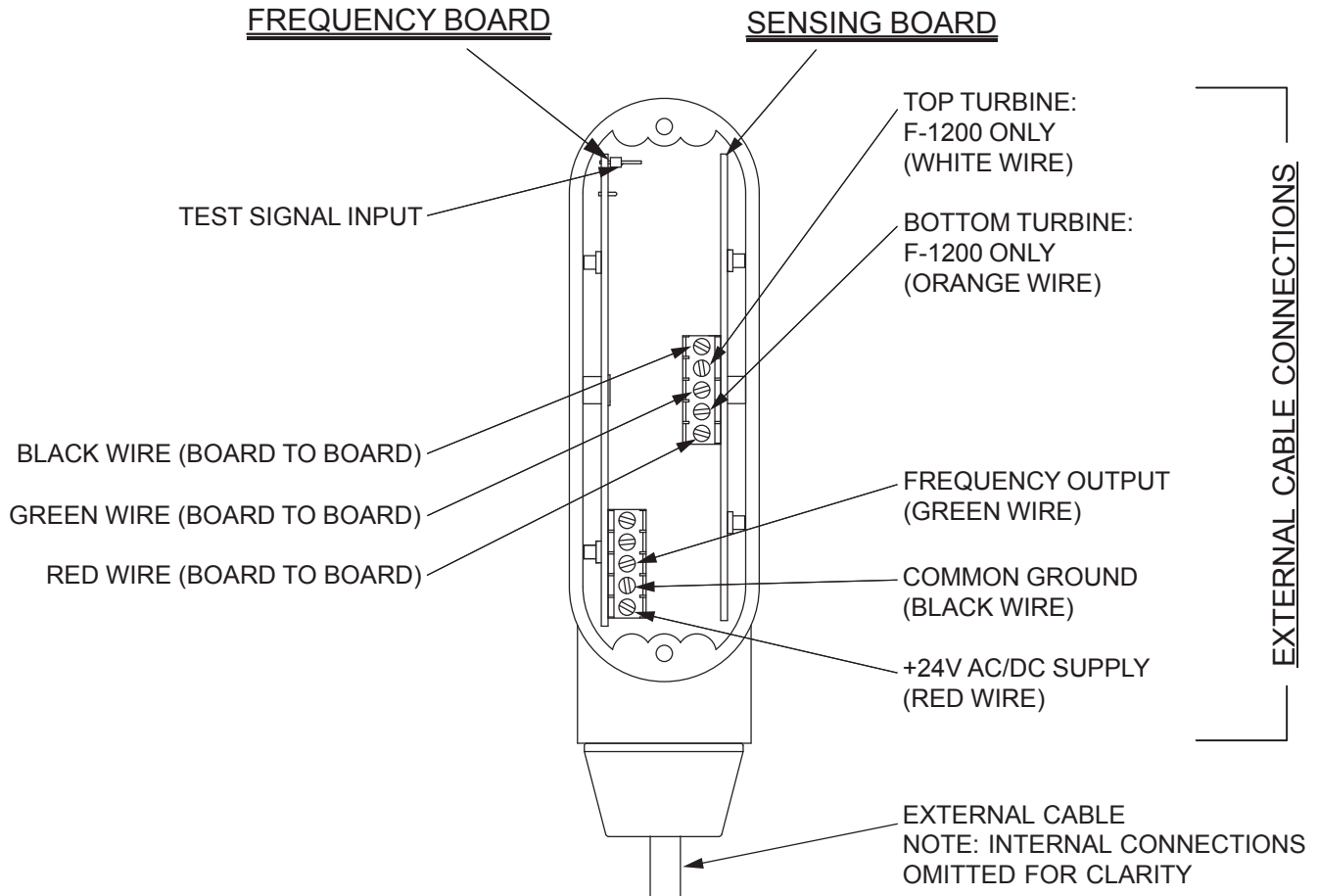

NOTES:

FLOW METER WIRING INFORMATION

User Connections for Models with Non-Isolated Analog Outputs

Models: F-1110, F-1210, FB-1210 & F-1310

				Wiring Information		
F-1110 Single Turbine	F-1310 Inline	F-1210 Dual Turbine	FB-1210 Bi-Directional	WIRE COLOR CODE		NOTES
✓	✓	✓	✓	RED*	(+) 24 ± 4 V AC/DC supply voltage	Connect to power supply positive
✓	✓	✓	✓	BLACK	(-) Common ground (Common with pipe ground)	Connect to power supply negative & analog input ground
✓	✓	✓	✓	GREEN	(+) Frequency output signal: 0-15 V peak pulse	Required when meter is connected to local display or BTU meter
✓	✓	✓	✓	BLUE	(+) Analog signal: 4-20 mA (non-isolated)	Both signals may be used independently (unless 0-5 V output is ordered)
✓	✓	✓	✓	BROWN	(+) Analog signal: 0-10 V (non-isolated) (Can also be ordered as 0-5 V)	
			✓	GRAY	Dry contact directional output - indicates flow direction	Contact closed when flow is in direction of arrow on meter
			✓	VIOLET		
DIAGNOSTIC SIGNALS						
		✓	✓	ORANGE	Bottom turbine frequency	These signals are for diagnostic purposes - connect to local display or BTU meter
		✓	✓	WHITE	Top turbine frequency	

F-1110 / F-1210 / F-1310 Wiring Diagram

Connections to a Control System (No Display or BTU Meter)

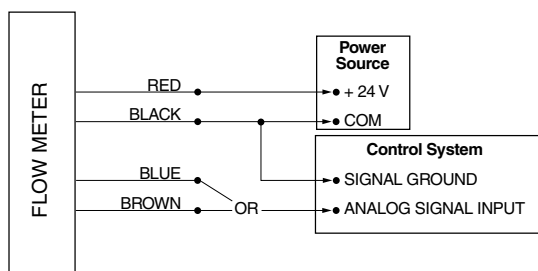

FB-1210 Wiring Diagram

Connections to a Control System (No Display or BTU Meter)

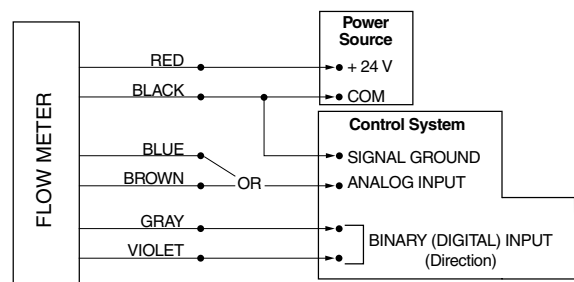

- NOTES:
- * 1. Serial Numbers 115691 and earlier require 24 VDC. Serial Numbers 115692 and higher can accept 24 V AC/DC.
 2. Black wire is common with the pipe (typically earth ground).
 3. For ONICON display module or BTU meter, connect all wires provided. Refer to wiring diagram provided with display or BTU meter.



CAUTION

This is NOT a “loop-powered” instrument. DO NOT connect power to any of the signal output wires (blue, brown, green, orange or white)

**WIRING DIAGRAM
INTERNAL CONNECTIONS FOR
NON-ISOLATED ANALOG OUTPUT
FLOW METERS
MODELS F-1110 / F-1210 / F-1310**

For use with serial numbers
115692 and later

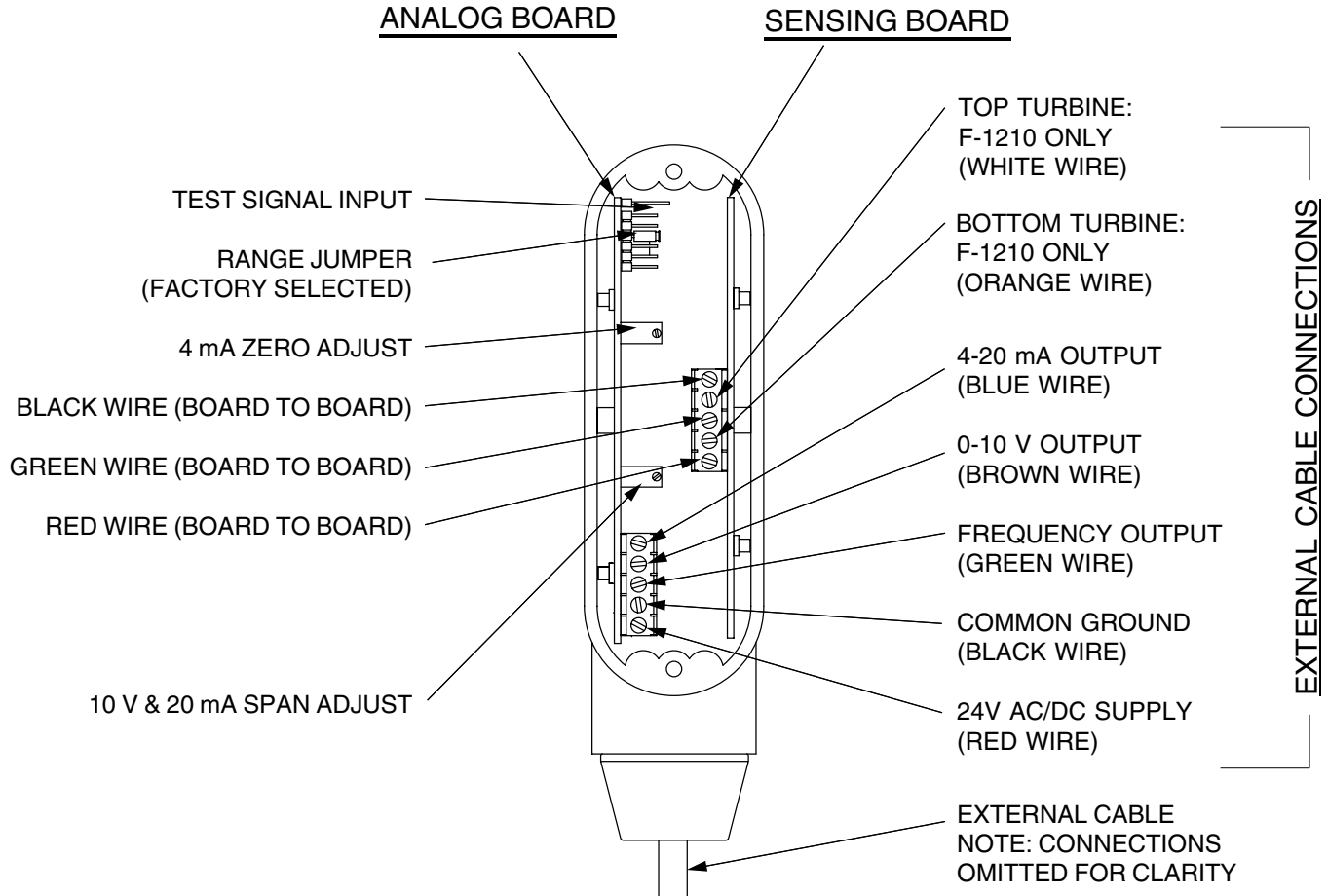

NOTES:

FLOW METER WIRING INFORMATION

User Connections for Models with Isolated Analog Outputs

Models: F-1111, F-1211, FB-1211 & F-1311

				Wiring Information		
F-1111 Single Turbine	F-1311 Inline	F-1211 Dual Turbine	FB-1211 Bi-Directional	WIRE COLOR CODE	NOTES	
√	√	√	√	RED*	(+) 24 ± 4 V AC/DC supply voltage Connect to power supply positive	
√	√	√	√	BLACK	(-) Common ground (Common with pipe ground) Connect to power supply negative	
√	√	√	√	GREEN	(+) Frequency output signal: 0-15 V peak pulse Required when meter is connected to local display or BTU meter	
√	√	√	√	BLUE	(+) Analog signal: 4-20 mA (isolated)	
√	√	√	√	BROWN	(+) Analog signal: 0-10 V (isolated) (Can also be ordered as 0-5 V) Both signals may be used independently (unless 0-5 V output is ordered)	
√	√	√	√	YELLOW	(-) Isolated ground Use for analog signals only	
			√	GRAY	Dry contact directional output - indicates flow direction Contact closed when flow is in direction of arrow on meter	
			√	VIOLET		
DIAGNOSTIC SIGNALS						
		√	√	ORANGE	Bottom turbine frequency These signals are for diagnostic purposes - connect to local display or BTU meter	
		√	√	WHITE	Top turbine frequency	

F-1111 / F-1211 / F-1311 Wiring Diagram

Connections to a Control System (No Display or BTU Meter)

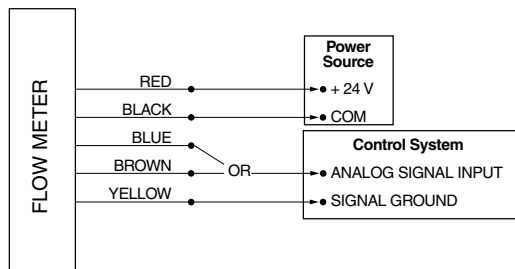

FB-1211 Wiring Diagram

Connections to a Control System (No Display or BTU Meter)

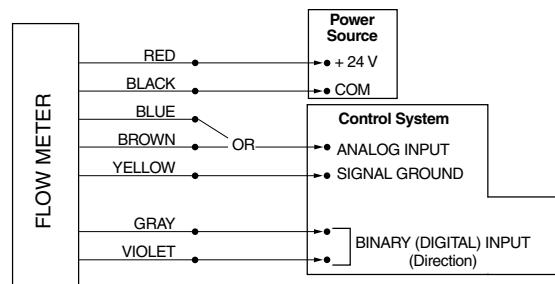

- NOTES: * 1. Serial Numbers 115691 and earlier require 24 VDC. Serial Numbers 115692 and higher can accept 24 V AC/DC.
2. Black wire is common with the pipe (typically earth ground).
3. For ONICON display module or BTU meter, connect all wires provided. Refer to wiring diagram provided with display or BTU meter.

CAUTION

This is NOT a "loop-powered" instrument. DO NOT connect power to any of the signal output wires (blue, brown, green, orange or white)



**WIRING DIAGRAM
INTERNAL CONNECTIONS FOR
ISOLATED ANALOG OUTPUT
FLOW METERS
MODELS F-1111 / F-1211 / F-1311**

For use with serial numbers
115692 and later

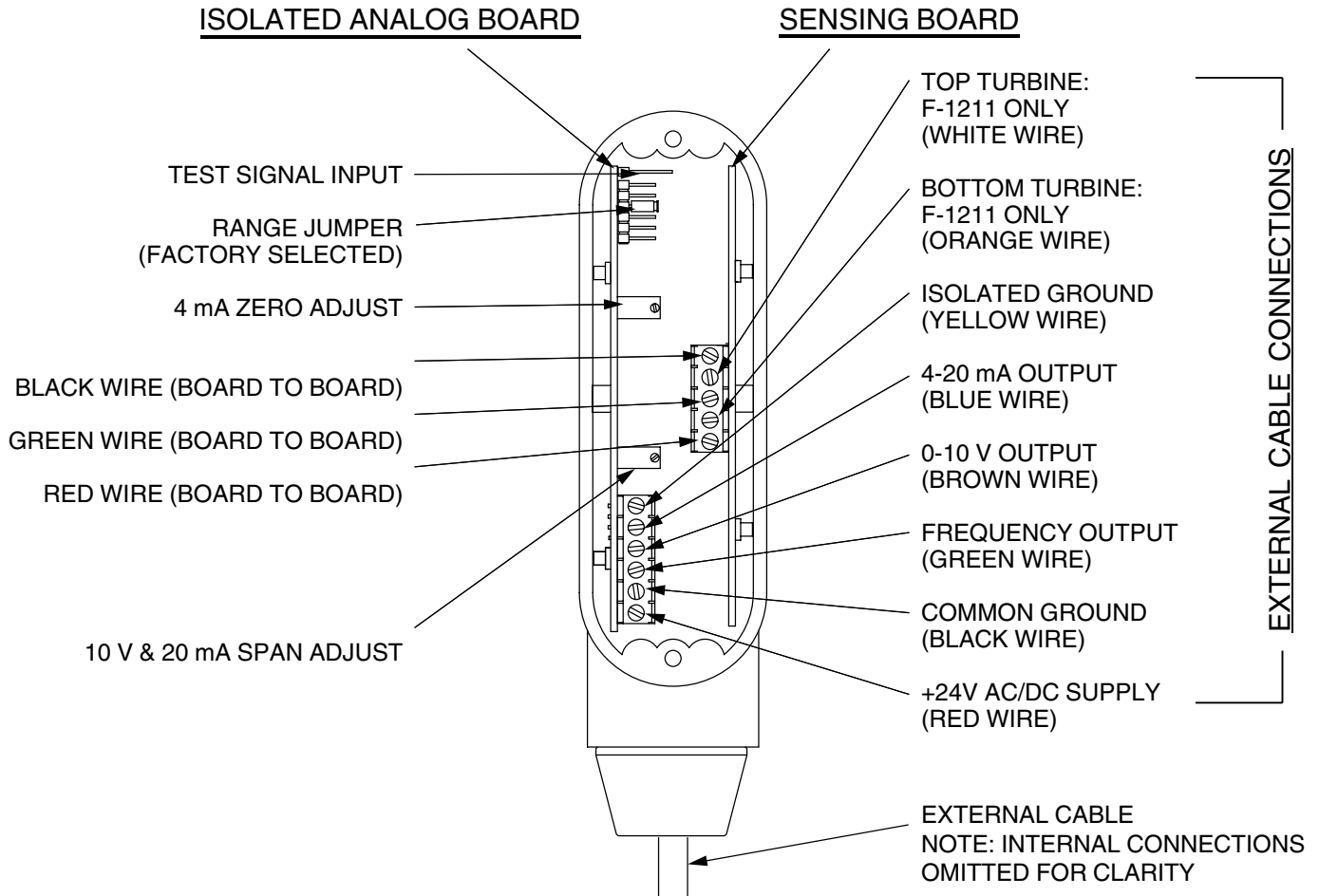

NOTES:

FLOW METER WIRING INFORMATION

User Connections for Models with Divided Output

Models: F-1120, F-1220, FB-1220 & F-1320

				Wiring Information		
F-1120 Single Turbine	F-1320 Inline	F-1220 Dual Turbine	FB-1220 Bi-Directional	WIRE COLOR CODE		NOTES
✓	✓	✓	✓	RED*	(+) 24 ± 4 V AC/DC supply voltage	Connect to power supply positive
✓	✓	✓	✓	BLACK	(-) Common ground (Common with pipe ground)	Connect to power supply negative
✓	✓	✓	✓	GREEN	(+) Frequency output signal: 0-15 V peak pulse	Required when meter is connected to local display or BTU meter
✓	✓	✓	✓	BLUE	Dry contact divided output - indicates flow rate	Output can be divided by any binary number up to 4096 to meet frequency limitations of control system
✓	✓	✓	✓	BROWN		
			✓	GRAY	Dry contact directional output - indicates flow direction	Contact closed when flow is in direction of arrow on meter
			✓	VIOLET		
DIAGNOSTIC SIGNALS						
		✓	✓	ORANGE	Bottom turbine frequency	These signals are for diagnostic purposes - connect to local display or BTU meter
		✓	✓	WHITE	Top turbine frequency	

F-1120 / F-1220 / F-1320 Wiring Diagram

Connections to a Control System (No Display or BTU Meter)

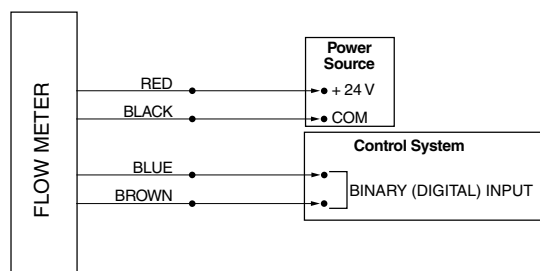

FB-1220 Wiring Diagram

Connections to a Control System (No Display or BTU Meter)

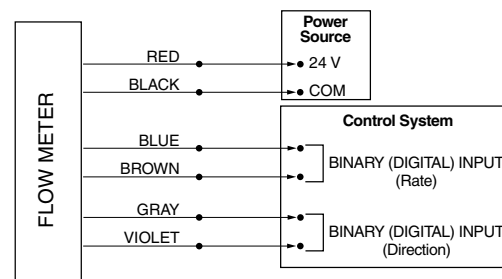

- NOTES:
- * 1. Serial Numbers 115691 and earlier require 24 VDC. Serial Numbers 115692 and higher can accept 24 V AC/DC.
 2. Black wire is common with the pipe (typically earth ground).
 3. For ONICON display module or BTU meter, connect all wires provided. Refer to wiring diagram provided with display or BTU meter.

WIRING DIAGRAM INTERNAL CONNECTIONS FOR DIVIDED OUTPUT FLOW METERS MODELS F-1120 / F-1220 / F-1320



For use with serial numbers
115692 and later

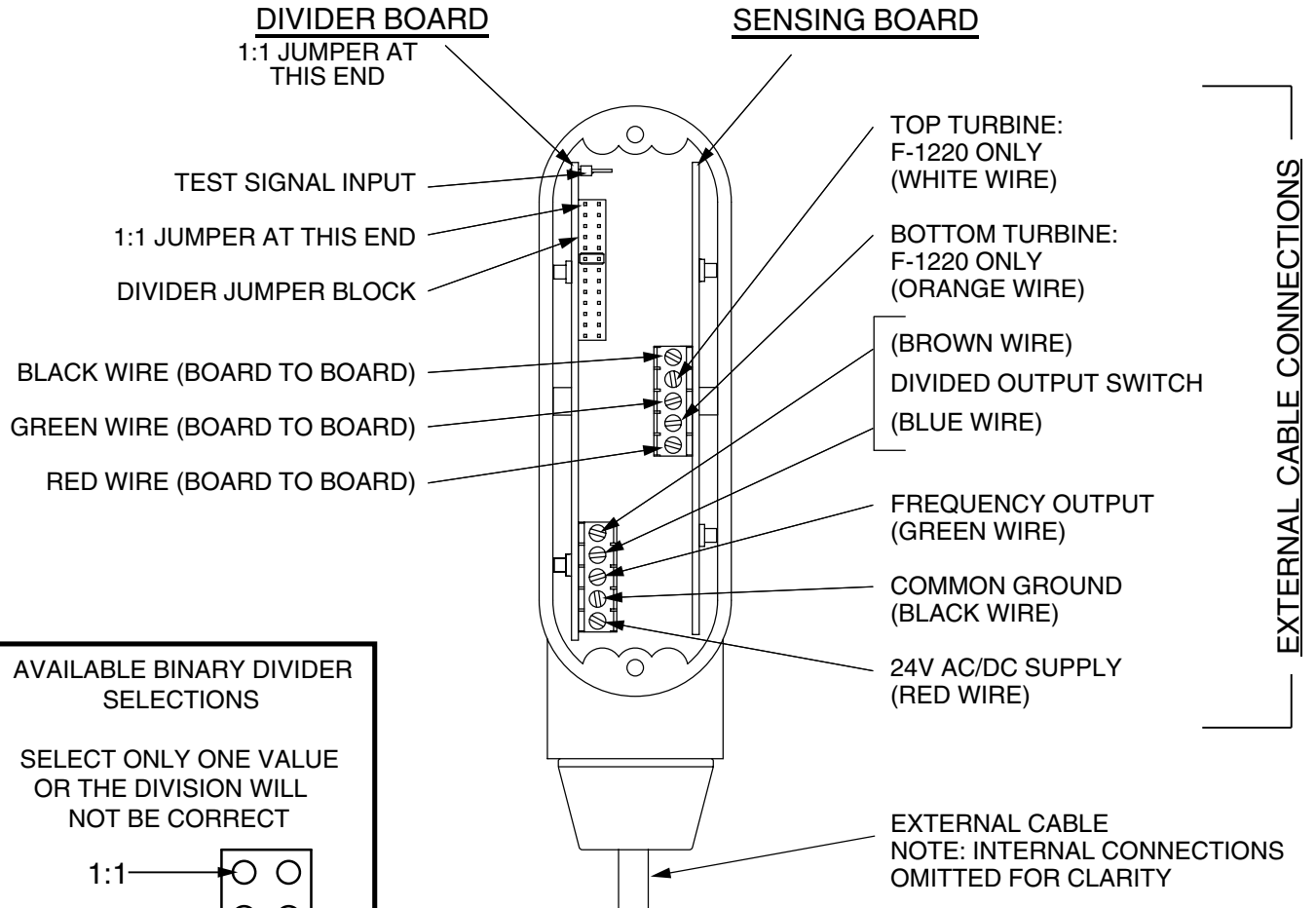

AVAILABLE BINARY DIVIDER SELECTIONS

SELECT ONLY ONE VALUE
OR THE DIVISION WILL
NOT BE CORRECT

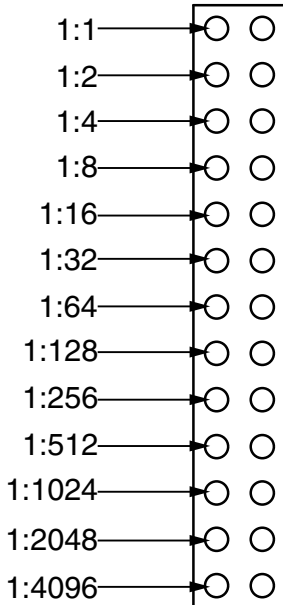

NOTES:

EXTERNAL CABLE
NOTE: INTERNAL CONNECTIONS
OMITTED FOR CLARITY

FLOW METER WIRING INFORMATION

User Connections for Models with Scaled Output

Models: F-1130, F-1230, FB-1230 & F-1330

				Wiring Information		
F-1130 Single Turbine	F-1330 Inline	F-1230 Dual Turbine	FB-1230 Bi-Directional	WIRE COLOR CODE		NOTES
√	√	√	√	RED*	(+) 24 ± 4 V AC/DC supply voltage	Connect to power supply positive
√	√	√	√	BLACK	(-) Common ground (Common with pipe ground)	Connect to power supply negative
√	√	√	√	GREEN	(+) Frequency output signal: 0-15 V peak pulse	Required when meter is connected to local display or BTU meter
√	√	√	√	BLUE	Dry contact scaled output	Scaled to provide one pulse per volumetric unit Examples: 1 pulse per 10 gal. 1 pulse per 100 gal.
√	√	√	√	BROWN		
			√	GRAY	Dry contact directional output - indicates flow direction	Contact closed when flow is in direction of arrow on meter
			√	VIOLET		
				DIAGNOSTIC SIGNALS		
		√	√	ORANGE	Bottom turbine frequency	These signals are for diagnostic purposes - connect to local display or BTU meter
		√	√	WHITE	Top turbine frequency	

F-1130 / F-1230 / F-1330 Wiring Diagram

Connections to a Control System (No Display or BTU Meter)

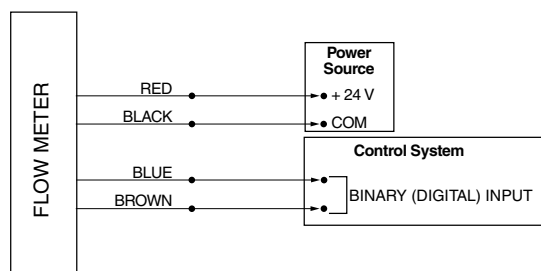

FB-1230 Wiring Diagram

Connections to a Control System (No Display or BTU Meter)

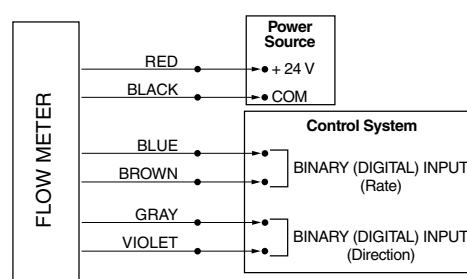

- NOTES:
- * 1. Serial Numbers 115691 and earlier require 24 VDC. Serial Numbers 115692 and higher can accept 24 V AC/DC.
 2. Black wire is common with the pipe (typically earth ground).
 3. For ONICON display module or BTU meter, connect all wires provided. Refer to wiring diagram provided with display or BTU meter.

WIRING DIAGRAM INTERNAL CONNECTIONS FOR SCALED OUTPUT FLOW METERS MODELS F-1130 / F-1230 / F-1330

For use with serial numbers
115692 and later

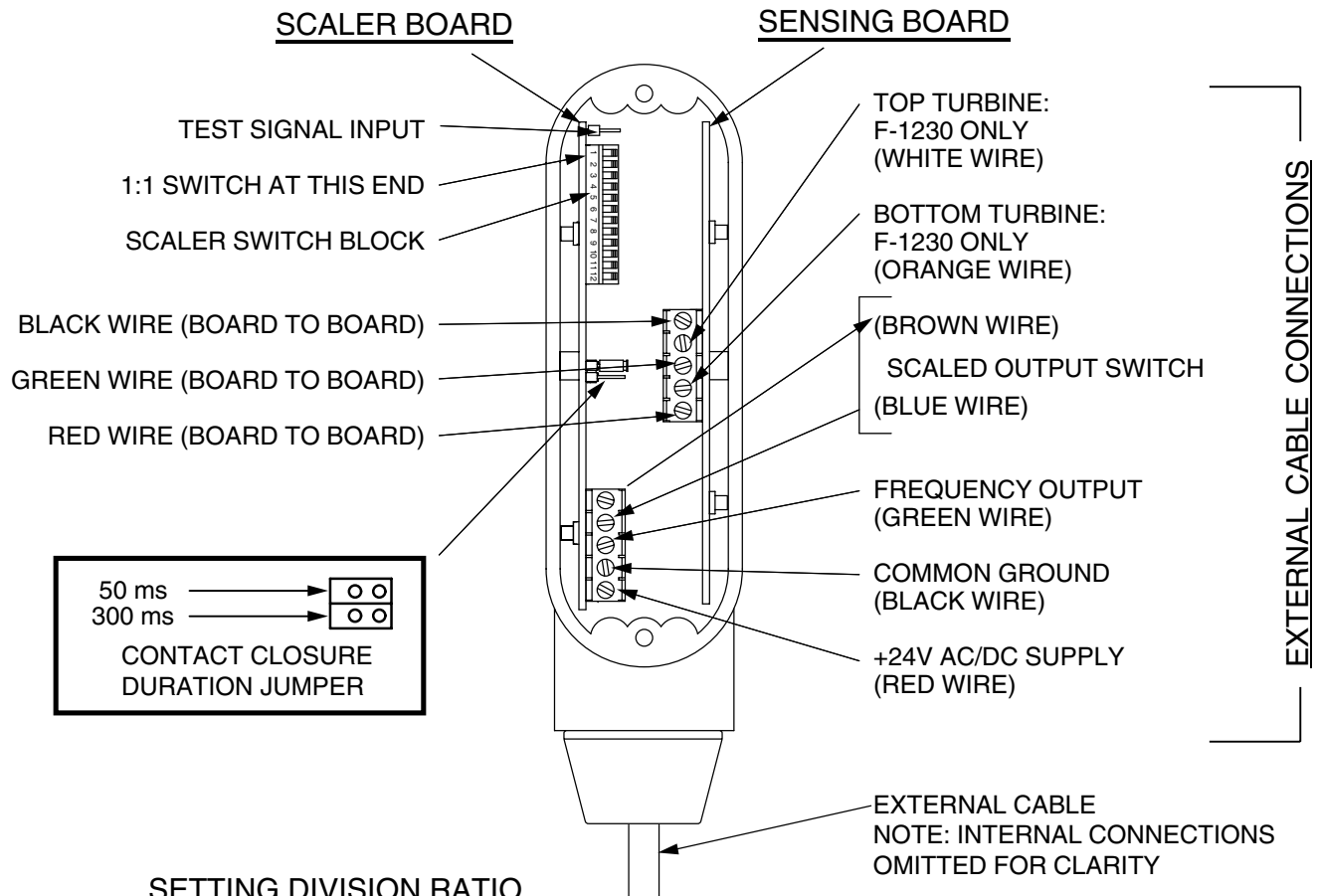

SETTING DIVISION RATIO

Available binary
scaler selections

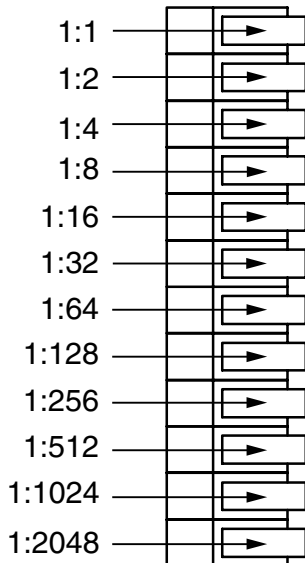

To set division ratio, turn ON each switch that is required to produce an arithmetic sum equal to the desired ratio. For example:

SW	VAL
1	1
2	2
3	4
4	8
5	16
6	32
7	64
8	128
9	256
10	512
11	1024
12	2048

DESIRED RATIO = 629

Subtract the largest possible switch value.

$$629 - 512 = 117$$

$$117 - 64 = 53$$

$$53 - 32 = 21$$

$$21 - 16 = 5$$

$$5 - 4 = 1$$

$$1 - 1 = 0$$

$$512 + 64 + 32 + 16 + 4 + 1 = 629$$

SET SWITCHES

10, 7, 6, 5, 3, & 1
TO "ON"

NOTES:

APPENDIX B

Installation Hardware Instructions

Installation Hardware Instructions

Standard Installation Kit for Welded Steel Pipe

For F-1100, F-1200 & FB-1200 Series Insertion Turbine Flow Meters



For Use With Kits: INSTL1, INSTL5, INSTL18

This kit must be installed prior to filling the system, or into a section of pipe that is isolated from pressure and flow. Once installed, this kit allows for insertion and removal of the flow meter without a system shutdown.

Directions:

1. Identify an appropriate location for the flow meter (see Sections 3.1 and 3.2).
2. Weld the branch outlet onto the pipe.
3. Drill a one inch (minimum) access hole, centered in the branch outlet.
4. Install the close nipple and ball valve as shown below. Use a paste type thread sealant. DO NOT use Teflon® tape.
5. Flush and fill the system prior to installing the flow meter.

IMPORTANT NOTE

ONICON insertion flow meters are precision measuring devices that must be installed according to the instructions contained in this document in order to maintain their accuracy and reliability. Failure to follow these instructions will result in erratic operation and reduced accuracy.

NOTE: Before installing the flow meter, read the entire installation manual.

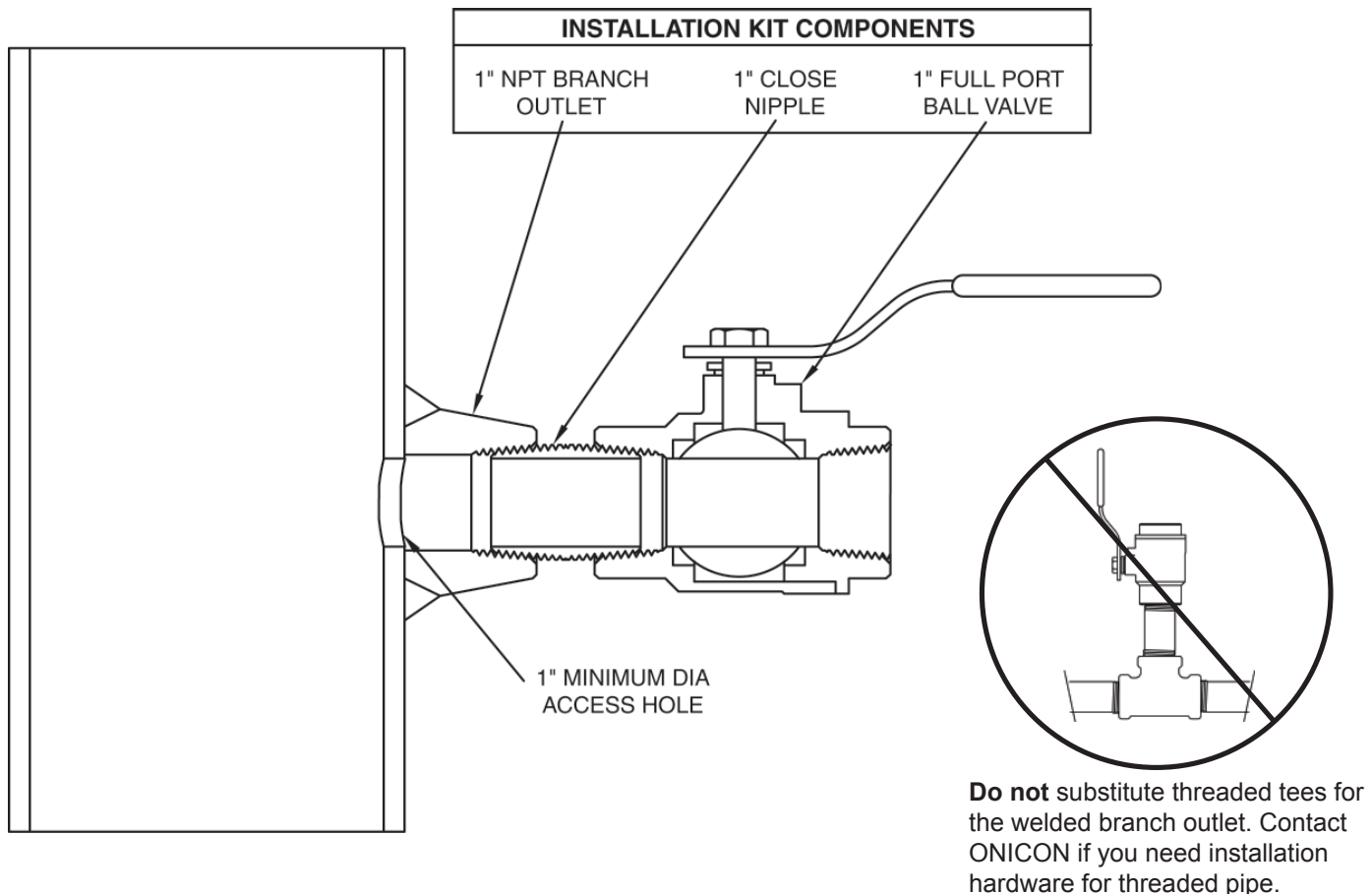

Installation Hardware Instructions

Hot Tap Installation Kit for Welded Steel Pipe

For F-1100, F-1200 & FB-1200 Series Insertion Turbine Flow Meters



For Use With Kits: INSTL2, INSTL6, INSTL31

This kit can be installed on a pressurized pipe. A hot tap drilling machine is used to create a one inch opening in the pipe wall. Once installed, this kit allows for insertion and removal of the flow meter without a system shutdown.

Directions:

1. Identify an appropriate location for the flow meter (see Sections 3.1 and 3.2).
2. Weld the branch outlet onto the pipe.
3. Install the close nipple and ball valve as shown below. Use a paste type thread sealant. **DO NOT** use Teflon® tape.
4. Use a hot tap drilling machine with a 1" hole saw to drill the access hole.
5. Remove the drill; then flush all debris out of the valve.
6. Use the 1" reducer provided in this kit when installing the flow meter

Important Note

ONICON insertion flow meters are precision measuring devices that must be installed according to the instructions contained in this document in order to maintain their accuracy and reliability. Failure to follow these instructions will result in erratic operation and reduced accuracy.

NOTE: Before installing the flow meter, read the entire installation manual.

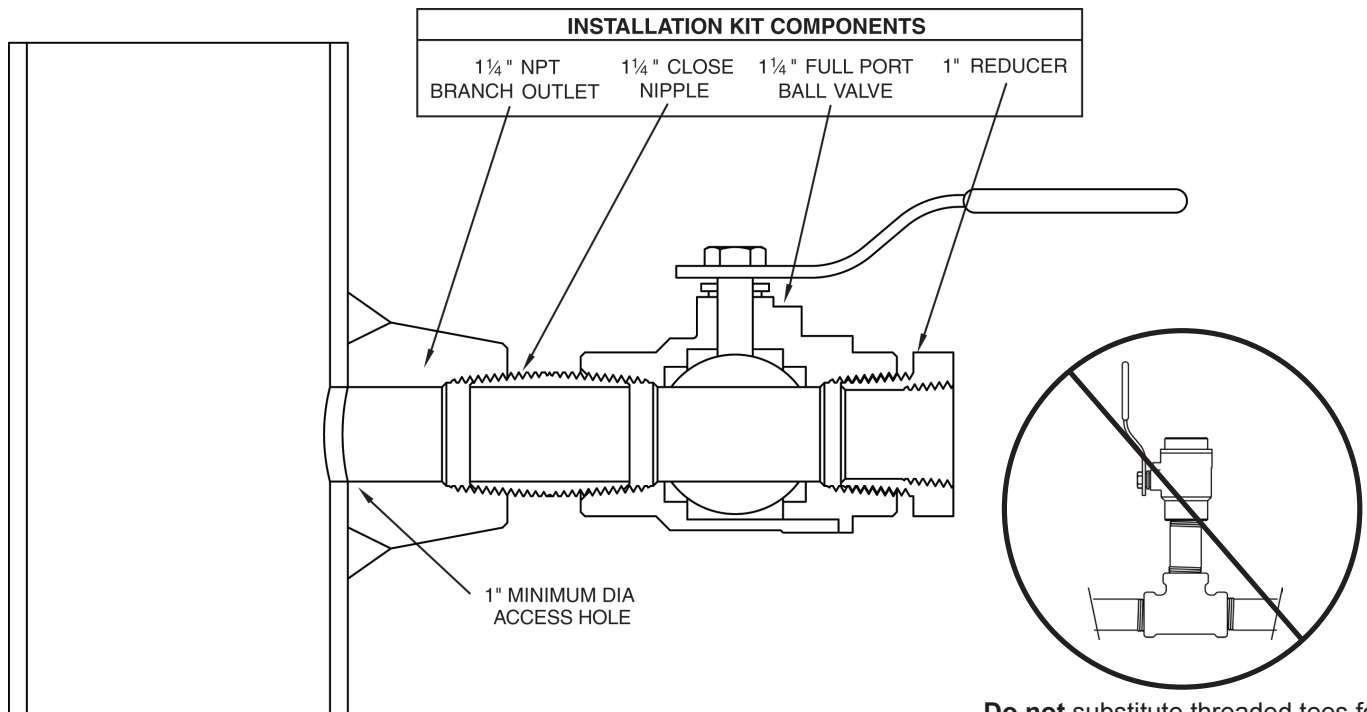

Do not substitute threaded tees for the welded branch outlet. Contact ONICON if you need installation hardware for threaded pipe.

Installation Hardware Instructions

Standard Installation Kit For Copper Tube

(Components Comply with NSF61)



For F-1100, F-1200 & FB-1200 Series Insertion Turbine Flow Meters

For Use With Kits: INSTL3 (>1") INSTL4 & INSTL9

This kit must be installed prior to filling the system, or into a section of pipe that is isolated from pressure and flow. Once installed, this kit allows for insertion and removal of the flow meter without a system shutdown.

Directions:

1. Identify an appropriate location for the flow meter (see Sections 3.1 and 3.2).
2. Solder or braze the copper tee and adapter provided.
3. Install the ball valve as shown below. Use a paste type thread sealant. DO NOT use Teflon[®] tape.
4. Flush and fill the system prior to installing the meter.

Important Note
ONICON insertion flow meters are precision measuring devices that must be installed according to the instructions contained in this document in order to maintain their accuracy and reliability. Failure to follow these instructions will result in erratic operation and reduced accuracy.

NOTE: Before installing the flow meter, read the entire installation manual.

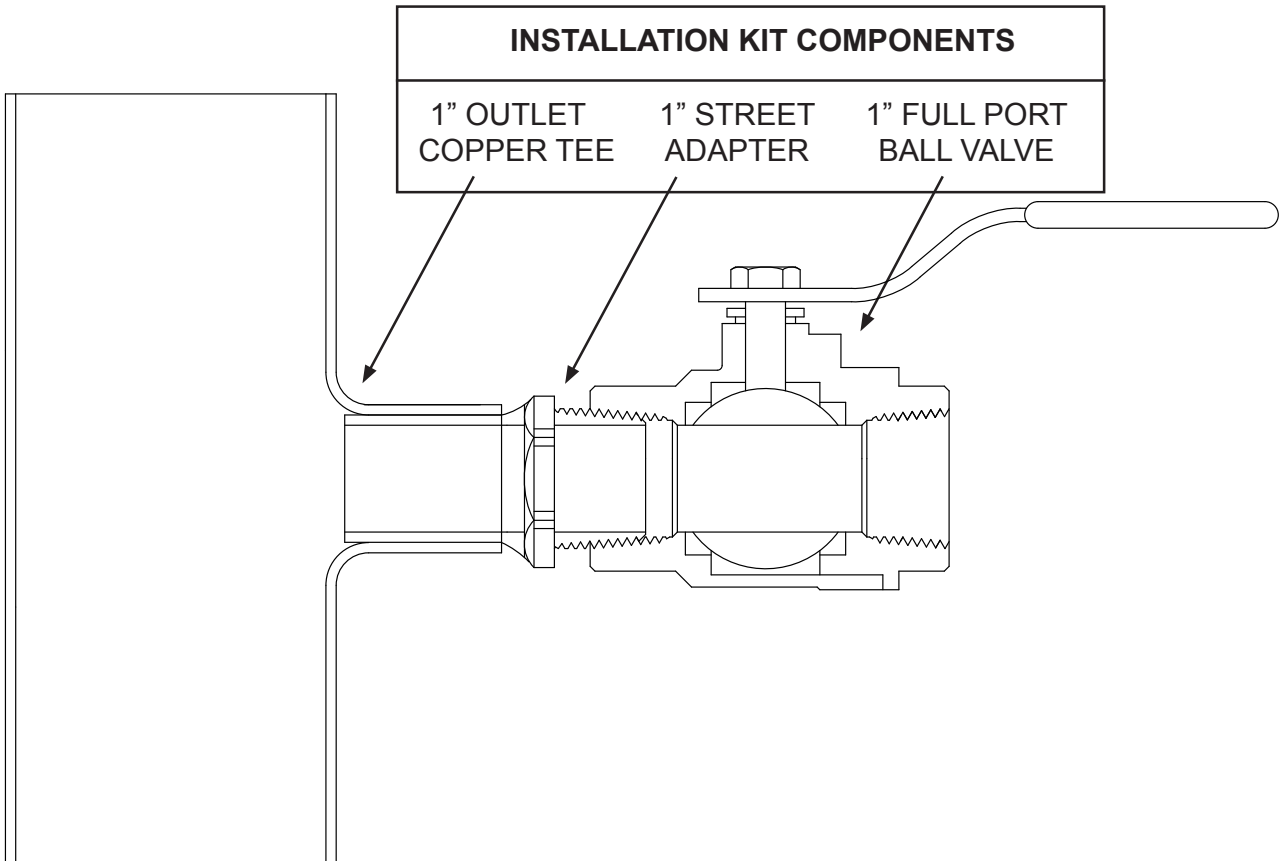

Installation Hardware Instructions

Standard Installation Kit For 1" Copper Tube

(Complies with NSF61)

For F-1100 Series Insertion Turbine Flow Meters



For Use With Kit INSTL3 (1")

This kit must be installed prior to filling the system, or into a section of pipe that is isolated from pressure and flow. Once installed, this kit allows for insertion and removal of the flow meter without a system shutdown.

Directions:

1. Identify an appropriate location for the flow meter (see Sections 3.1 and 3.2).
2. Solder or braze the copper tee and adapters provided.
3. Install the ball valve as shown below. Use a paste type thread sealant. DO NOT use Teflon[®] tape.
4. Flush and fill the system prior to installing the meter.

NOTE: Before installing the flow meter, read the entire installation manual.

Important Note

ONICON insertion flow meters are precision measuring devices that must be installed according to the instructions contained in this document in order to maintain their accuracy and reliability. Failure to follow these instructions will result in erratic operation and reduced accuracy.

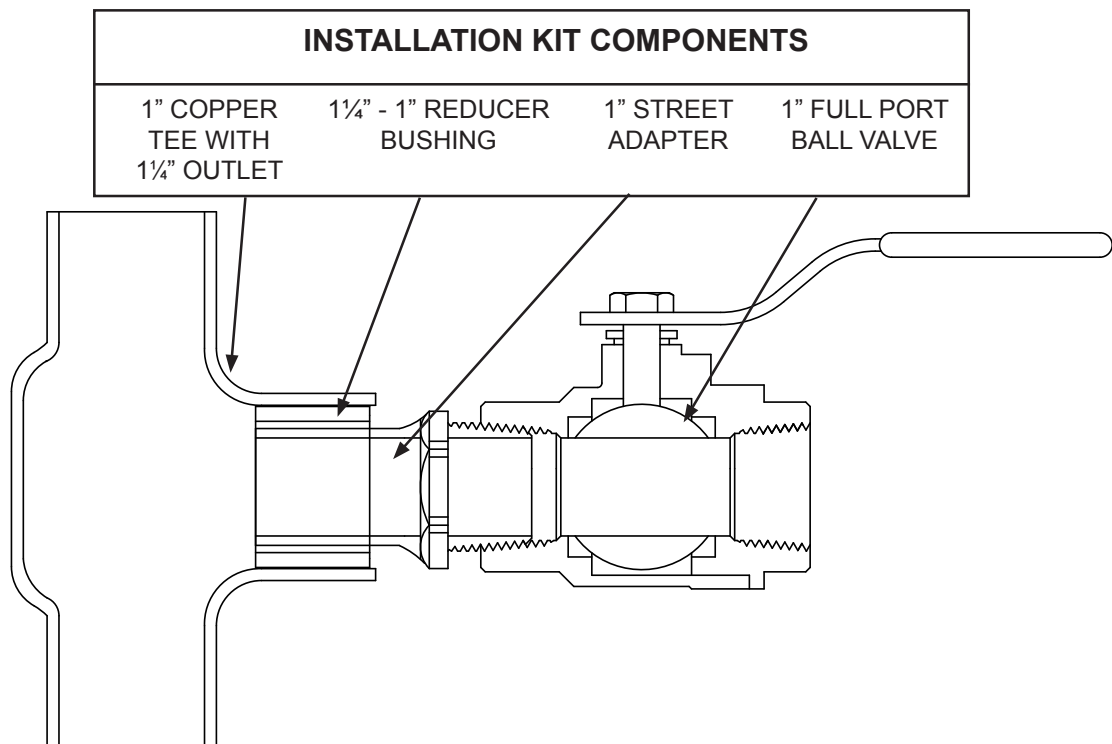

Installation Hardware Instructions
Standard Installation Kit for Applications Requiring Pipe Saddles
 For F-1100, F-1200 & FB-1200 Series Insertion Turbine Flow Meters



**For Use With Kits: INSTL10, INSTL11, INSTL12, INSTL13,
 INSTL14, INSTL15, INSTL16, INSTL17**

This kit must be installed prior to filling the system, or into a section of pipe that is isolated from pressure and flow. Once installed, this kit allows for insertion and removal of the flow meter without a system shutdown.

Directions:

1. Identify an appropriate location for the flow meter (see Sections 3.1 and 3.2).
2. Clamp the saddle onto the pipe; refer to manufacturer's instructions.
3. Drill a 1" (minimum) access hole in the pipe, centered in the outlet.
4. Install the reducer, close nipple and ball valve as shown below. Use a paste type thread sealant. **DO NOT** use Teflon® tape.
5. Flush and fill the system prior to installing the meter.

Important Note

ONICON insertion flow meters are precision measuring devices that must be installed according to the instructions contained in this document in order to maintain their accuracy and reliability. Failure to follow these instructions will result in erratic operation and reduced accuracy.

NOTE: Before installing the flow meter, read the entire installation manual.

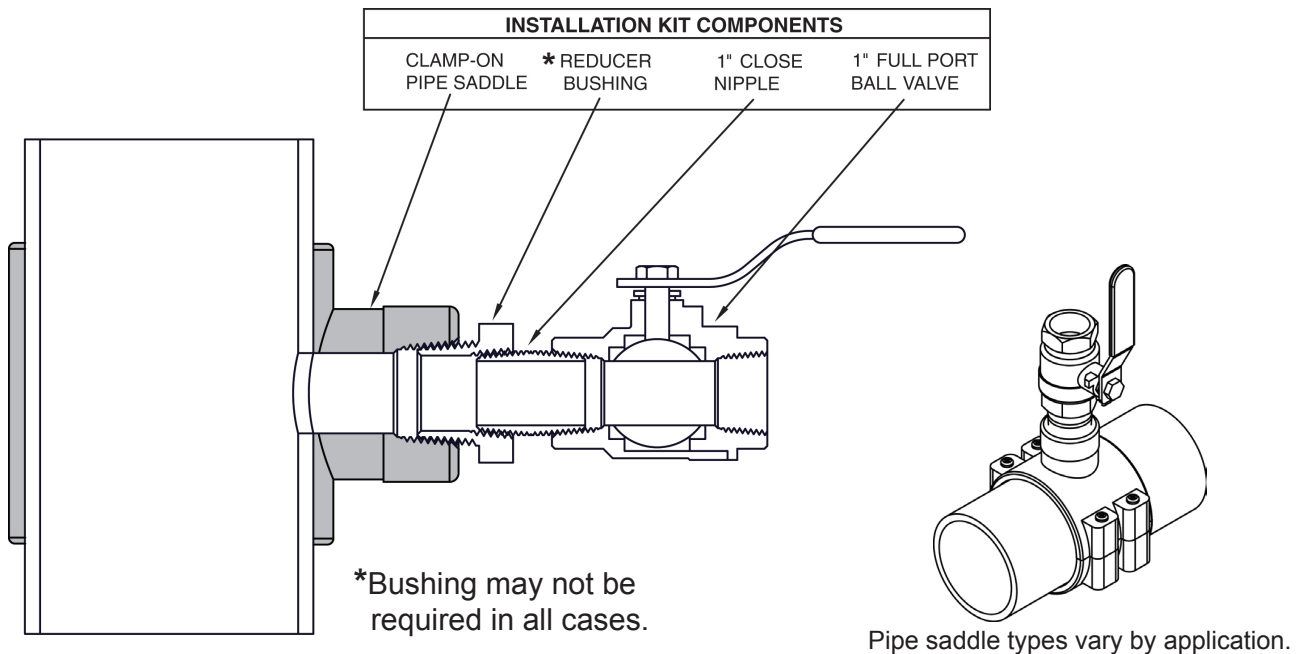

Important Note

ONICON provides pipe saddles to facilitate the installation of our flow meters. Separate installation instructions accompany the saddle. Please follow these instructions when installing the saddle. Pay particular attention to bolt torque specifications and temperature/pressure limits.

Installation Hardware Instructions

Hot Tap Installation Kit for Applications Requiring Pipe Saddles

For F-1100, F-1200 & FB-1200 Series Insertion Turbine Flow Meters



For Use With Kits: INSTL19, INSTL20, INSTL21, INSTL22, INSTL23, INSTL24, INSTL25, INSTL26, INSTL27, INSTL28, INSTL29, INSTL30, INSTL75

This kit can be installed on a pressurized pipe. A hot tap drilling machine is used to create a one inch opening in the pipe wall. Once installed, this kit allows for insertion and removal of the flow meter without a system shutdown.

Directions:

1. Identify an appropriate location for the flow meter (see Sections 3.1 and 3.2).
2. Clamp the saddle onto the pipe; refer to manufacturer's instructions.
3. Install the close nipple and ball valve as shown below. Use a paste type thread sealant. DO NOT use Teflon® tape.
4. Use a hot tap drilling machine with a 1" hole saw to drill the access hole.
5. Remove the drill; then flush all debris out of the valve.
6. Use the 1" reducer provided in this kit when installing the flow meter.

Important Note

ONICON insertion flow meters are precision measuring devices that must be installed according to the instructions contained in this document in order to maintain their accuracy and reliability. Failure to follow these instructions will result in erratic operation and reduced accuracy.

NOTE: Before installing the flow meter, read the entire installation manual.

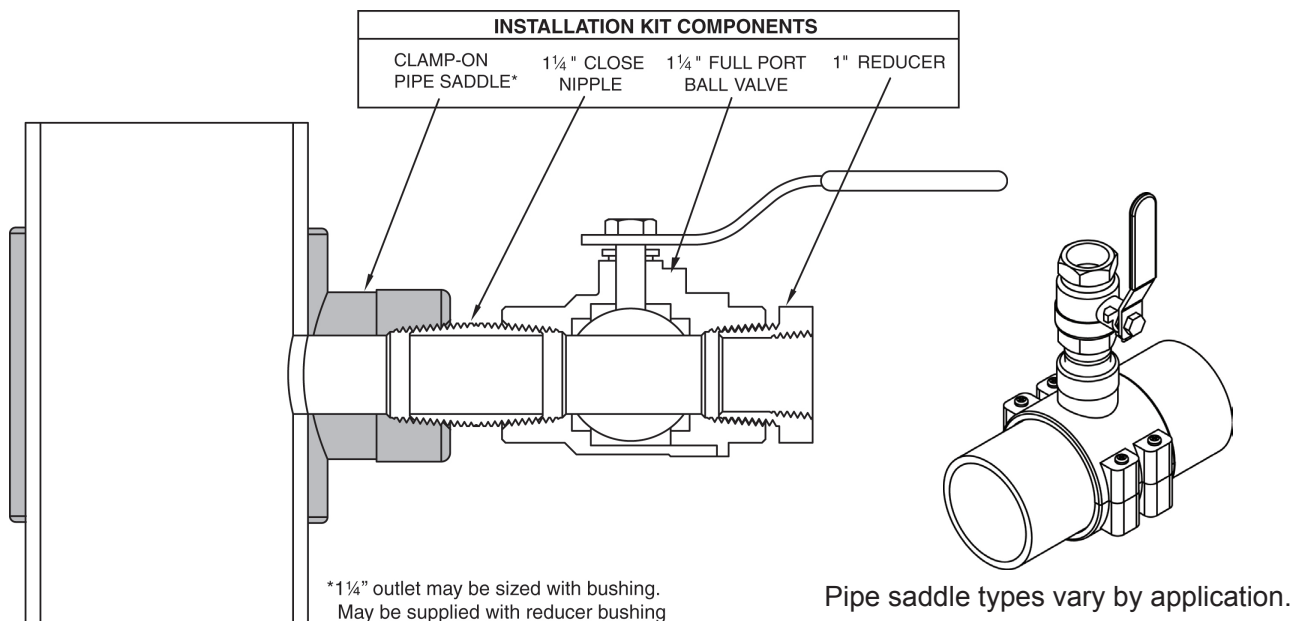

Important Note

ONICON provides pipe saddles to facilitate the installation of our flow meters. These saddles are purchased from leading manufacturers who provide quality products. Separate installation instructions accompany the saddle. Please follow these instructions when installing the saddle. Pay particular attention to bolt torque specifications and temperature/pressure limits.

Installation Hardware Instructions

Standard Installation Kit for 1¼” – 2½” Threaded Pipe

For F-1100, F-1200 & FB-1200 Series Insertion Turbine Flow Meters



For Use With Kits: INSTL7, INSTL8

This kit must be installed prior to filling the system, or into a section of pipe that is isolated from pressure and flow. Once installed, this kit allows for insertion and removal of the flow meter without a system shutdown.

Directions:

1. Identify an appropriate location for the flow meter (see Sections 3.1 and 3.2).
2. Install the threaded pipe nipple, close nipple and ball valve as shown below. Use a paste type thread sealant. **DO NOT** use Teflon® tape.
3. Flush and fill the system prior to installing the meter.

NOTE: Before installing the flow meter, read the entire installation manual.

Important Note

ONICON insertion flow meters are precision measuring devices that must be installed according to the instructions contained in this document in order to maintain their accuracy and reliability. Failure to follow these instructions will result in erratic operation and reduced accuracy.

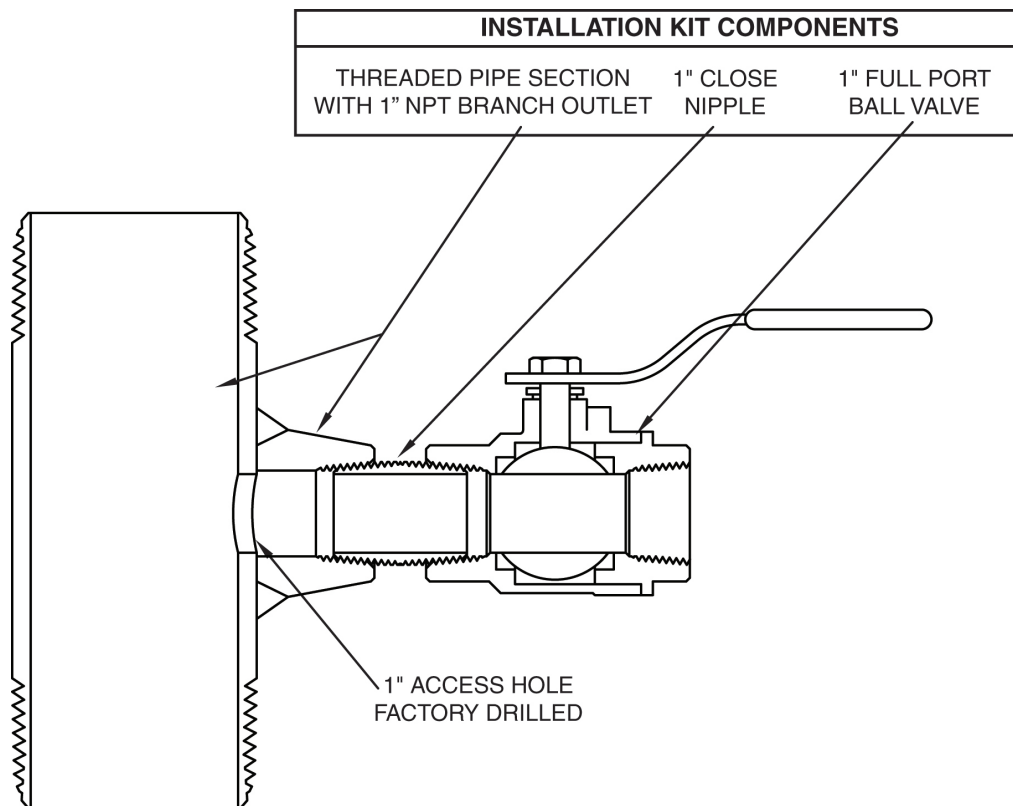

APPENDIX C

Turbine Assembly Detail Drawings



TURBINE ASSEMBLY DETAILS
for
ALL MODELS IN F-1100 SERIES

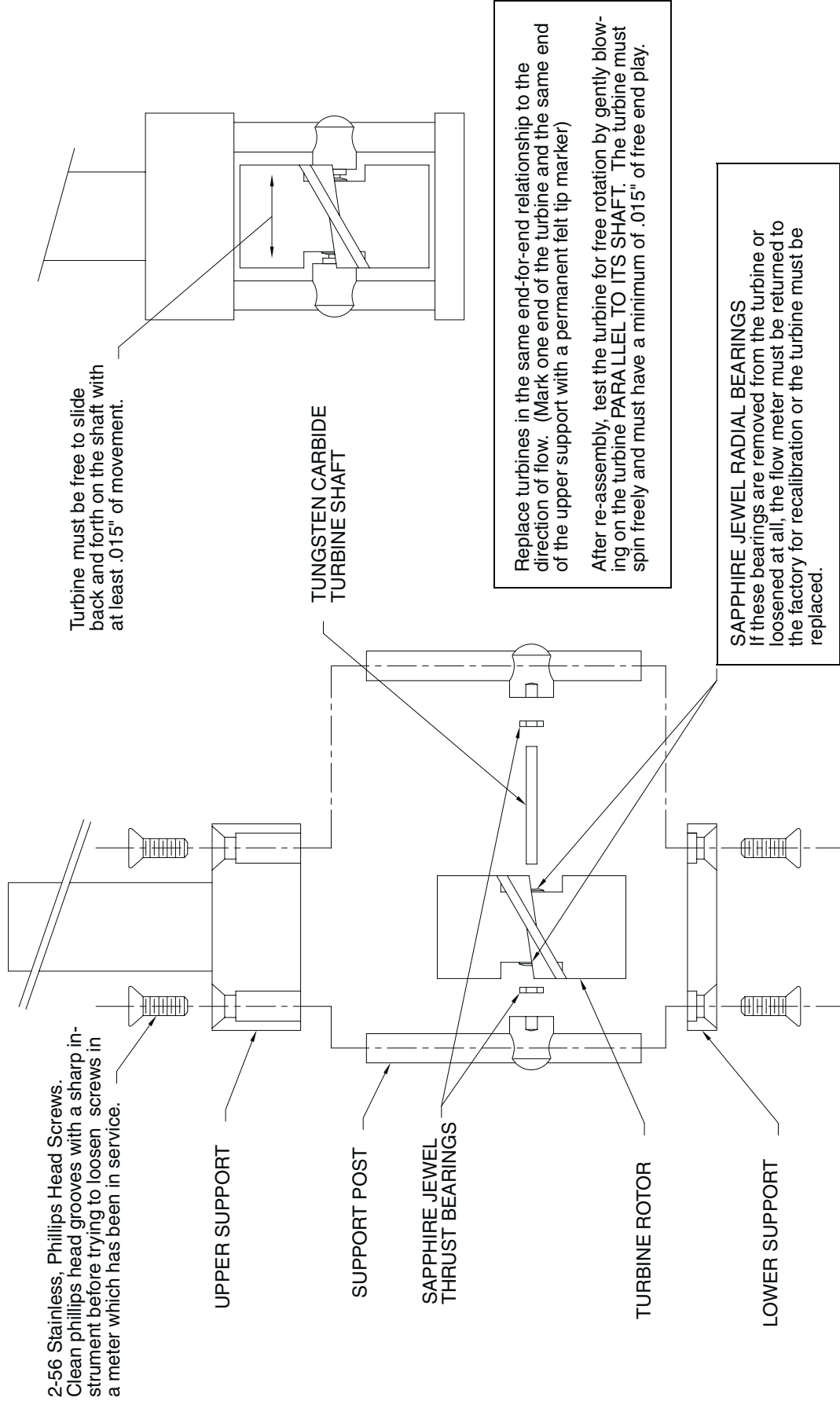



TURBINE ASSEMBLY DETAILS
for
ALL MODELS IN F-1200 SERIES

2-56 STAINLESS, PHILLIPS HEAD SCREWS.
Clean phillips head grooves with a sharp instrument
before trying to loosen screws in a meter which has
been in service.

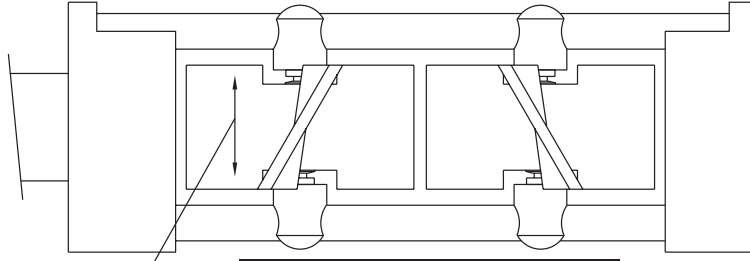

Turbines must be free to slide
back and forth on the shaft with
at least .015" of movement.

Replace turbines in the same upper or
lower location and in the same end-for-
end relationship to the direction of flow.
(Mark one end of each turbine and the
same end of the upper support with a per-
manent felt tip marker)

After re-assembly, test the turbines for
free rotation by gently blowing on the tur-
bines **PARALLEL TO THEIR SHAFTS**.
The turbines must spin freely and must
have a minimum of .015" of free end play.

SAPPHIRE JEWEL RADIAL BEARINGS
If these bearings are removed from the turbines or
loosened at all, the flow meter must be returned to
the factory for recalibration or the turbines must be
replaced.

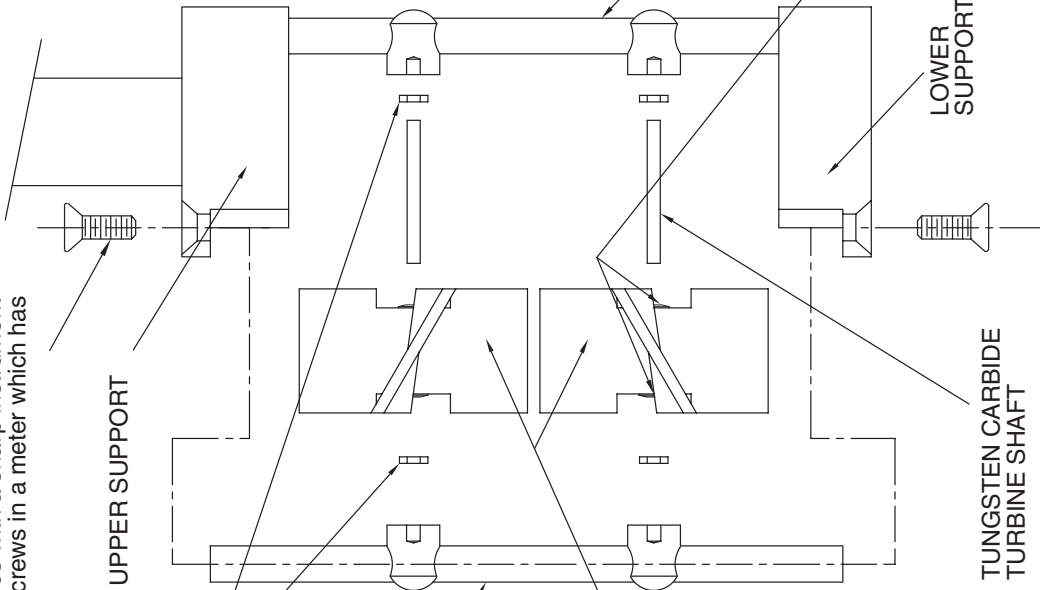

SAPPHIRE JEWEL
THRUST BEARINGS

REMOVABLE
SUPPORT POST

TURBINE
ROTORS

NON-REMOVABLE
SUPPORT POST

LOWER
SUPPORT

TUNGSTEN CARBIDE
TURBINE SHAFT

APPENDIX D

Conditions of Sale

CONDITIONS OF SALE

- 1. ACCEPTANCE:** The following Conditions of Sale apply to all sales of ONICON's products. These provisions shall apply even if ONICON fails to object to provisions appearing on, incorporated by, referenced in, or attached to Buyer's purchase order form. Buyer's acceptance of delivery of ONICON's products constitutes its acceptance of these Conditions of Sale.
- 2. DELIVERY AND TITLE:** All product shipments are F.O.B. shipping point and title passes to the Buyer at the time ONICON delivers the merchandise to the carrier. Risk of loss or damage to the product passes to the Buyer at the time ONICON delivers the product to the carrier. The Buyer immediately upon receipt should inspect all shipments, and should there be any evidence of damage or loss in transit, Buyer must file claims or tracers upon carrier. ONICON will assist in tracing shipments upon request.
- 3. LIMITED WARRANTY:** ONICON warrants that for a period of two (2) years following the date of original shipment of an ONICON product: (i) the product will conform to ONICON's standard written specifications applicable to such product in effect on the date of Buyer's order, or as modified by ONICON's quotation or Buyer's purchase order accepted by ONICON, (ii) the product will be free from defects in workmanship, and (iii) that ONICON has title to the product prior to shipment to the Buyer; provided, however, that the warranties provided herein shall be void and may not apply in the event Buyer misuses or damages a product, including, but not limited to, any use by the Buyer of a product for an application other than one of a type approved by ONICON. ONICON's sole liability and Buyer's sole remedy for any breach of the foregoing warranty is for ONICON to repair or replace, at ONICON's option, any defective product that is returned to ONICON during the warranty period. EXCEPT AS MAY BE SPECIFICALLY AGREED BY ONICON IN WRITING IN RELATION TO EACH SALE, NO OTHER WARRANTIES SHALL APPLY, WHETHER EXPRESSED, IMPLIED OR STATUTORY, AND THERE SHALL BE NO IMPLIED WARRANTIES OF MERCHANTABILITY AND FITNESS FOR A PARTICULAR PURPOSE.
- 4. REMEDIES:** ONICON's OBLIGATION UNDER THE FOREGOING WARRANTIES IS LIMITED SOLELY TO REPAIR OR REPLACEMENT, AT ONICON'S OPTION, OF DEFECTIVE OR NONCONFORMING PRODUCTS. ONICON SHALL NOT BE LIABLE FOR CONSEQUENTIAL, INDIRECT, PUNITIVE, INCIDENTAL, OR SPECIAL DAMAGES WHETHER FOUND ON CONTRACT, TORT OR ANY OTHER THEORY OF LAW. No products shall be returned to ONICON without its prior consent and transportation and insurance costs shall be prepaid. Any repair or replacement of ONICON's products under the foregoing warranty will be at no charge to the Buyer provided such repair is done at the ONICON factory or authorized service center. ONICON products that are repaired or replaced under this warranty will be returned to Buyer via the same method of shipment use to return the product to ONICON. Repair or replacement of ONICON products is conditioned upon ONICON's acknowledgement of any alleged defect or nonconformance during the warranty period and issuance of a Return Authorization number. All product returns must reference the Return Authorization number on the outside of the shipping carton and on any paperwork referencing the return.
- 5. PRICES AND PAYMENT TERMS:** The prices set forth in the most recent quote or acknowledgement as applicable, supersede all previous prices or quotations. All quotations are subject to change or withdrawal without notice except as may be specifically noted on the face of the quotation. The prices shown do not include sales, excise or government charges payable by ONICON to Federal, State, or local authority. Any such tax or charge now or hereafter imposed upon the sale or shipment of the products under this contract will be added to the purchase price. Buyer agrees to reimburse ONICON for such tax or charge or provide ONICON with an acceptable exemption certificate. Payment of invoices will be due 30 days from the date of shipment of the products contained therein. In the event that payment of an invoice is not received by the invoice due date, ONICON will assess a late fee not to exceed 1.5% per month or 18% per year, or the maximum allowable by law whichever is lower.
- 6. CANCELLATION:** Buyer may cancel its order, or any part of it, by sending written notice of cancellation to ONICON and paying a reasonable cancellation fee as determined by ONICON. The reasonable cancellation fee will reflect, among other factors, the expenses already incurred and commitments made by ONICON, sales and administrative costs and profit as determined by ONICON. If Buyer received a reduced price based on the quantity of products ordered, but has not purchased the applicable quantity at the time of cancellation, Buyer will pay the price it would have paid had ONICON's sale price been based on the quantity actually purchased.
- 7. CHANGES:** If Buyer makes any changes in its drawings, designs, or specifications applicable in any contract with ONICON that cause an increase or decrease in the cost of performance of the contract, or if such changes result in rework or obsolescence, an equitable adjustment shall be made to the contract. Such changes are subject to ONICON's prior written consent.
- 8. EXCUSABLE DELAY:** ONICON shall under no circumstance be responsible for failure to fill any order or orders when due to: fires, floods, riots, strikes, freight embargoes or transportation delays, shortage of labor, inability to secure fuel, material supplies, or power at current price or on account of shortages thereof, acts of God or of the public enemy, any existing or future laws or acts of the Federal or State Government (including specifically, but not exclusively, and orders, rules or regulations issued by any official or agency of any such government) affecting the conduct of ONICON's business with which ONICON in its judgment and discretion deems it advisable to comply as a legal or patriotic duty, or due to any cause beyond ONICON's reasonable control.
- 9. PATENTS:** ONICON shall defend all suits or proceedings brought against Buyer or its customers arising from claimed infringements of any patent, trademark, service mark or copyright for any product furnished by ONICON and shall indemnify it against all costs, fees, and damages on the condition Buyer promptly notifies ONICON in writing and provides information and assistance to enable ONICON to conduct the defense, provided that ONICON shall have no such obligation in case of infringement resulting from ONICON's conformance to special requirements of Buyer. If ONICON is not able to settle any such suit or proceeding on acceptable terms, ONICON may, at its option, require return of the infringing product and refund the purchase price to Buyer less a reasonable allowance for depreciation or use.
- 10. FAIR LABOR STANDARDS ACT:** ONICON represents that all products delivered under this contract are furnished in accordance with the applicable provisions of the Fair Labor Standards Act as amended.
- 11. APPLICABLE LAW:** This document and any resulting contract shall be governed by and construed in accordance with the laws of the State of Florida. The courts of the State of Florida and the federal courts located in Florida shall have jurisdiction and venue with respect to litigation to this contract. In the event of litigation, the prevailing party shall be entitled to recover attorney's fees and costs from the non-prevailing party, including appellate attorney's fees.
- 12. MODIFICATIONS:** These Conditions of Sale along with the prices, quantities delivery schedules and other provisions and instructions in applicable quotations by shall constitute the entire agreement between ONICON and Buyer pertaining to any resulting contract. They can be modified only in writing.

