

# Tee Strainers

**Applications:** These strainers are designed to protect downstream equipment from loose scale, weld slag, grit and other foreign material. They are ideal for insertion upstream of gas meters and regulators. Screens are stainless steel and available in 20, 40, 60, 80, 100 and 120 mesh.

**Tee Strainers** have a removable Screen Cylinder.

- Removable cap permits element to be easily inspected and cleaned.
- Seal gaskets constructed of resilient polyvinyl.
- Available in 1" to 4" NPT and 2" – 4" ANSI 150 Flanged
- Pete's plug can also be installed for easy pressure verification.



### Construction

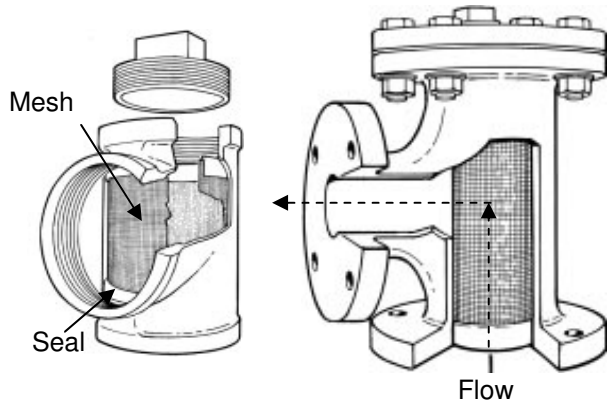

### Dimensions

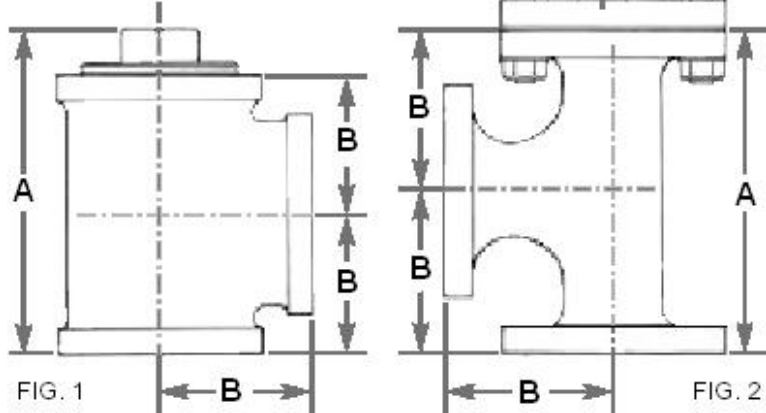

### Typical Installation

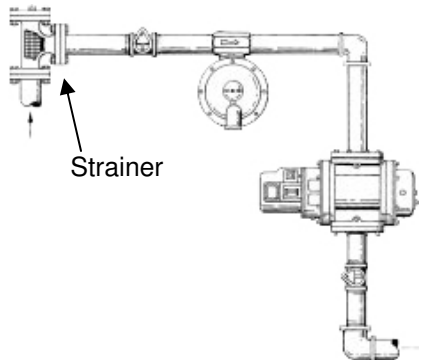

FIG 1	A	B
1"	3 5/8"	1 1/2"
1 1/2"	4 3/4"	1 7/8"
2"	5 1/2"	2 1/4"
3"	7 1/8"	3 3/16"
4"	9 1/2"	3 15/16"

FIG 2.	A	B
2" FL	9 7/16"	4 1/2"
3" FL	11 13/16"	5 1/2"
4" FL	13 7/8"	6 1/2"

Install the T-strainer upstream of the regulator to protect both devices.

For Sales & Service Contact:  
 Meter, Valve & Control  
 1499 Sunnybrook Road  
 Alamo, CA 94507  
 Phone: (877)566-3837  
 Fax: (925) 407-2903

**Meter, Valve & Control**  
 www.metervalveandcontrol.com  
[sales@metervalveandcontrol.com](mailto:sales@metervalveandcontrol.com)

Doc. Ref: F02A\_T\_Strainer\_FFC\_v. 1

Distributed By



**Meter, Valve & Control**  
**877-566-3837**