



B35 Series Regulator

R, N, and M Field Service Regulator

The B35 is specially designed for safe, accurate first stage pressure reduction on high pressure gas systems. It is a versatile pounds to pounds unit which is ideal for high pressure industrial, rural, and suburban taps.

DESCRIPTION

With a malleable iron body, the B35 will handle inlet pressures up to 1000 PSIG. Outlet pressures range from 5 to 150 PSIG. Seven different orifices are available from 1/16" through 1/2" in either brass or stainless steel. They are interchangeable in all valve body sizes.

» B35N

The B35N is a spring loaded field service regulator with no internal relief. Used primarily where internal relief is not required, but has a 1/4" NPT breather vent in the upper diaphragm case. This regulator has inlet pressure capabilities up to 1000 PSIG

» B35R

The B35R can be used for multi-regulator cuts with complete safety on installations up to 1000 PSIG inlet with reductions up to 150 PSIG and ultimately to down to 7 inches of water column outlet without an external relief valve and will conform to the ANSI B31.8 standard

» B35M

Special B35M unit with sealed throat and downstream control tap. This regulator perfectly suited to be used in monitoring installations in series with an operating regulator when a failure is sensed by the downstream control line

BENEFITS

- » Economical
- » Heavy duty construction with a malleable iron body
- » Corrosion Resistant
- » Inlet pressure capabilities up to 1000 PSIG
- » No special start up procedures
- » Polyurethane seat ensures reliable "lockup" (up to 1000 PSIG inlet pressure)
- » Outlet pressure capabilities of 5 to 150 PSIG

- » Seven different orifices from 1/16" to 1/2" in either brass or stainless steel
- » Controlled breather orifice size eliminates pulsation and provides normal actuation at low flows
- » Relief indicator visible from long distance
- » Conforms with B31.8 standard

FEATURES

- » Interchangeable brass or stainless steel orifice
- » Spring-loaded internal relief valve assembly
- » Field interchangeable adjustment spring
- » 3/4" NPT and 1" NPT valve bodies available
- » 14 different assembly positions
- » External indicator when the regulator has relieved

SHIPPING WEIGHT

Six regulators per box Box weight: 80 lbs.

B35 DIMENSIONS (INCHES)

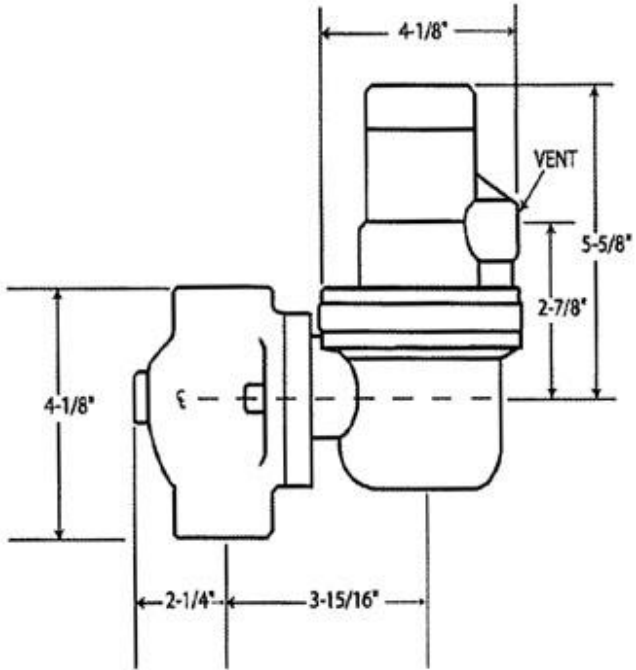

OPERATIONAL SCHEMATIC

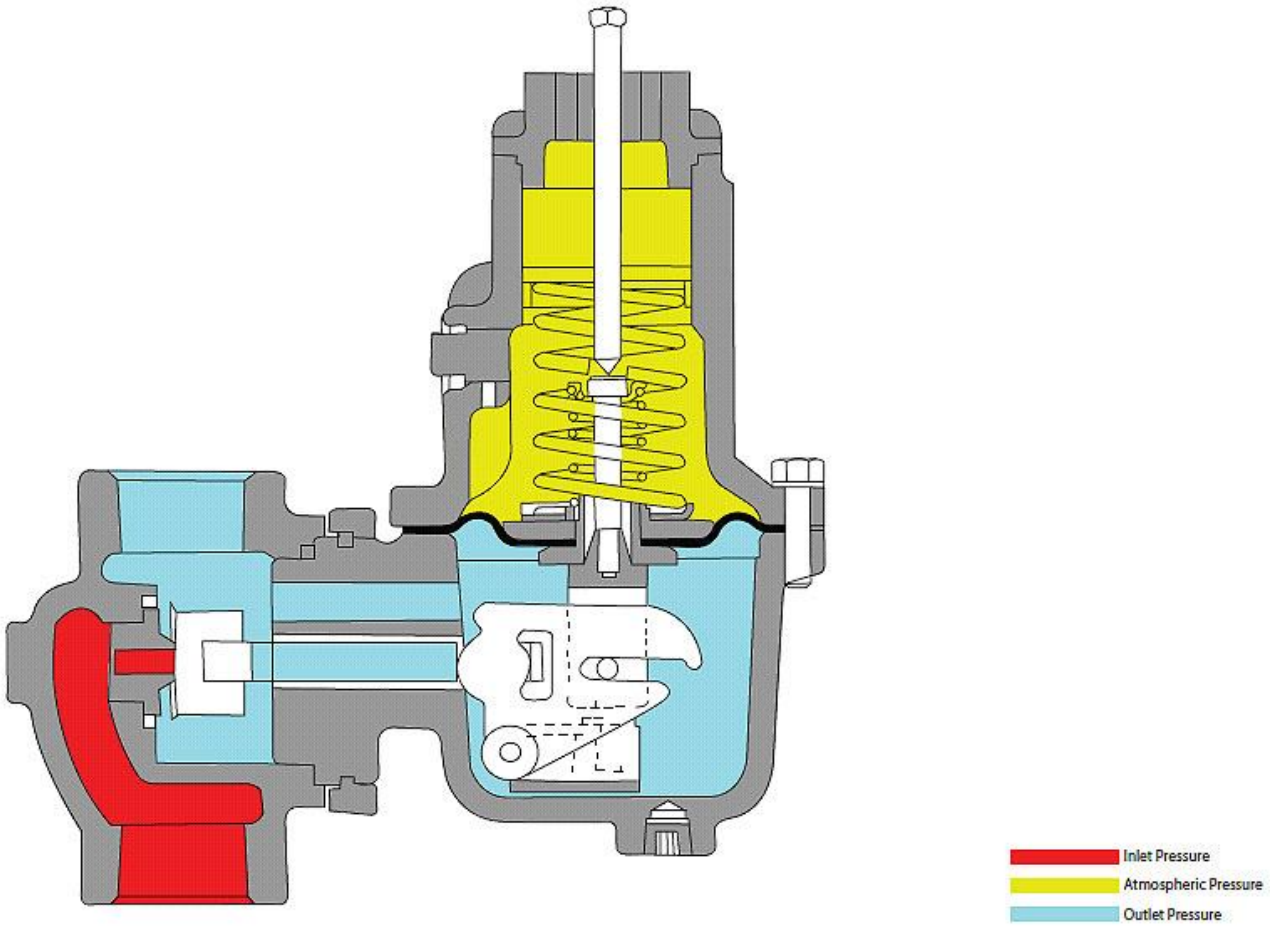

Note: valve shown in closed position.

SPRING DATA, SPRING COLOR OUTLET PRESSURE RANGE*

Color	PSIG
Green	5 - 8
Orange	8 - 15
Green/white	15 - 25
Blue/white	25 - 45
Silver	40 - 75
Yellow	70 - 100

*Note: Ranges are approximations, please contact manufacturer to obtain the best spring for application.

ORIFICE DATA, WIDE OPEN FLOW COEFFICIENTS AND MAXIMUM PRESSURES

Orifice Size (inches)	K-Factor	Maximum Operating Inlet Pressure (PSIG)	Maximum Emergency Inlet Pressure (PSIG)	Maximum Emergency Outlet Pressure (PSIG) (No Damage)	Maximum Emergency Outlet Pressure (PSIG) (Gas Containment)
1/16 x 3/32	8.9	1000 (DI Body)	1200 (DI Body)	150 PSIG + Outlet Pressure Set Point	1000
3/32	17.5				
1/8	30.0				
3/16	71.0				
1/4	127.0	600 (DI Body)			
3/8	290.0	300 (DI Body)			

INLET PRESSURE EFFECT*

Spring Color	Orifice Size (inches)					
	3/32	1/8	3/16	1/4	3/8	1/2
Green	400	220	140	70	50	20
Orange	380	220	130	70	40	20
Green/white	380	220	130	70	40	20
Blue/white	340	170	100	60	30	20
Silver	250	160	100	60	30	20
Yellow	220	140	90	60	30	20
Red	140	100	70	40	30	20

*Change in inlet pressure to change outlet Pressure by 1 PSIG.

OPERATING TEMPERATURE RANGE

-20°F to 150°F

ADDITIONAL SPECIFICATIONS

Available Pilot Vent Sizes	R Models: 3/4" (threaded NPT optional) N, M Models: 1/4" NPT
Maximum Capacity	35,000 scfh (see capacity tables)
Other Available Options	Seal wire to indicate unapproved tampering
	1/8" pipe plug tap on upstream side of valve body
	1/4" or 1/8" NPT tap on diaphragm case (for outlet pressure measurement)

CONSTRUCTION

Itron takes pride in delivering American made products with the utmost concern for safety, quality, and customer satisfaction.

Construction material

Valve body	Ductile iron or steel
Orifice	Brass (standard), Stainless steel (optional)
Valve seat	Polyurethane or nylon
Valve stem	Plated steel
Valve stem bushing	Brass
Lever pin	Stainless steel (Type 303)
Lever	Zinc and dichromate plated steel
Upper diaphragm plate	Zinc and dichromate plated steel
Lower diaphragm plate	Zinc and dichromate plated steel
Diaphragm	Buna-N and nylon reinforcing fabric
Pilot vent screen	Stainless steel
Adjustment ferrule	Plated steel
Seal cap	Cast iron
Diaphragm case	Ductile iron
Diaphragm case screws	Steel (Torx head), optional stainless steel with socket head

VALVE BODY SIZES

Body Size (inches)	Connection Type
Ductile Iron Body	
3/4" or 1"	NPT threaded

CORRECTION FACTORS FOR NON-NATURAL GAS APPLICATIONS

The B35 may be used to control gases other than natural gas. To determine the capacity for gases other than natural gas, multiply the values within the capacity tables by a correction factor. The table below lists the correction factors for some of the more common gases:

Gas Type	Specific Gravity	Correction Factor (CF)
Air	1.00	0.77
Butane	2.01	0.55
Carbon Dioxide (Dry)	1.52	0.63
Carbon Monoxide (Dry)	0.97	0.79
Natural Gas	0.60	1.00
Nitrogen	0.97	0.79
Propane	1.53	0.63
Propane-Air-Mix	1.20	0.71

To calculate the correction factor for gases not listed in the table above, use the gases' specific gravity and insert it in the formula listed below:

$$\text{Correction Factor (CF)} = \sqrt{\frac{SG_1}{SG_2}}$$

Where:

SG₁ = Specific gravity of the gas in which the capacity is published.

SG₂ = Specific gravity of the gas to be controlled.

Wide Open Flow Calculations

For wide-open orifice flow calculations use the following equations:

$$\text{For } \frac{P_1}{P_2} < 1.89 \text{ use: } Q = K\sqrt{P_2(P_1 - P_2)} \quad \text{For } \frac{P_1}{P_2} > 1.89 \text{ use: } Q = \frac{KP_1}{2}$$

Where: P₁ = Absolute Inlet Pressure (PSIA)

P₂ = Absolute Outlet Pressure (PSIA)

Q = Flow Rate (SCFH)

K = Orifice Coefficient (SCFH/PSI)

SPRING RANGES*

Use spring data table to obtain actual spring ranges for inlet pressures not listed.

Adjusted Outlet Pressure Range				
Spring Adjustment Ferrule at Minimum and Maximum Depths				
Spring Color	Orifice Size (inches)	Inlet Pressure (PSI)	Outlet Pressure	
			Minimum	Maximum
Green	3/32	200	1	6
	1/8	200	1	7
	3/16	200	2	8
	1/4	200	3	9
	3/8	200	5	11
	1/2	200	10	17
Orange	3/32	200	7	14
	1/8	200	7	14
	3/16	200	8	16
	1/4	200	9	16
	3/8	200	12	20
	1/2	200	18	24
Green/white	3/32	200	12	23
	1/8	200	12	23
	3/16	200	13	24
	1/4	200	14	24
	3/8	200	16	27
	1/2	200	22	31
Blue/white	3/32	500	22	42
	1/8	500	23	44
	3/16	500	25	46
	1/4	500	28	48
	3/8	300	28	48
	1/2	200	29	49
Silver	3/32	500	15	74
	1/8	500	16	76
	3/16	500	18	78
	1/4	500	20	80
	3/8	300	21	79
	1/2	200	23	79
Yellow	3/32	500	13	99
	1/8	500	14	100
	3/16	500	17	103
	1/4	500	19	104
	3/8	300	19	102
	1/2	200	20	102
Red	3/32	500	5	153
	1/8	500	7	155
	3/16	500	9	158
	1/4	500	12	158
	3/8	300	12	154
	1/2	200	13	152

*Minimum ferrule depth = 0.350, maximum ferrule depth = 1.065

B35 SERIES COMMERCIAL REGULATOR, MODELS M, N, AND R

Capacity Table (20% Gauge Droop*)

Capacities in SCFH of 0.6 S.G. gas; base conditions of 14.7 PSIA and 60° F.

Typical Capacity Info.	
Manufacturer	Itron
Type and model	B35
Regulator	
Spring color	Varies

Inlet Pressure (PSIG)	Outlet Pressure (PSIG)	Orifice Size (inches)						
		1/16" x 3/32"	3/32"	1/8"	3/16"	1/4"	3/8"	1/2"
15	10	95	190	330	780	1350	3500	3400
20	10	140	270	470	1100	1900	3400	4800
	15	105	210	360	850	1450	2700	3700
30	11 or less	200	390	670	1550	2700	4900	6900
	15	185	360	630	1450	2500	4600	6600
	20	165	320	550	1300	2200	4100	5700
50	22 or less	285	565	970	2300	3900	7000	10000
	25	275	550	930	2220	3700	6900	9700
	40	205	410	700	1650	2800	5100	7100
75	37 or less	395	780	1300	3100	5300	9800	14000
	50	360	710	1200	2800	4800	9000	12500
	60	295	580	1000	2300	4000	7600	10200
100	50 or less	500	1000	1700	4000	6900	12700	17800
	60	485	950	1600	3800	6500	12000	17000
	75	420	820	1400	3300	5700	10500	14500
150	68 or less	730	1400	2400	5800	10000	18300	25000
	75	700	1400	2400	5700	9800	18000	24500
	100	670	1300	2200	5300	9100	20000	23000
200	90 or less	950	1850	3200	7500	13000	23000	33000
	100	900	1800	3100	7400	12000	22000	32000
	150	800	1550	2700	6400	11000	20000	28000
300	140 or less	1350	2700	4700	11200	19000	35000	
	150	1300	2600	4600	11000	18500	34000	
400	150 or less	1800	3600	6200	14500	25000		
500	150 or less	2250	4300	7700	18200	31000		
600	150 or less	2700	5300	9200	21800	37000		
700	150 or less	3150	6200	10500	25000			
800	150 or less	3600	7200	12000	28600			
1000	150 or less	4500	8800	15000	36000			

*Individual regulator performance may vary from data shown.

 Inlet pressure exceeds orifice rating.

RELIEF PRESSURE DATA, SPRING COLOR OUTLET PRESSURE RANGE*

Spring Color	Outlet Pressure Set Point	Maximum Outlet Pressure	Maximum Inlet Pressure to stay below Maximum Outlet Pressure					
			Orifice Size (inches)					
			1/16 x 3/32	3/32	1/8	3/16	1/4	3/8
Green	5-10	60	1000	770	435	190	100	63
	5-10	125	1000	1000	1000	490	285	175
Orange	15	60	1000	690	400	180	100	63
	15	125	1000	1000	1000	490	280	175
Green/White	20	60	1000	590	345	150	95	62
	20	125	1000	1000	1000	490	280	175
Blue/White	30	60	1000	570	310	130	90	62
	40	75	1000	610	360	160	110	90
	40	125	1000	1000	890	420	270	160
Silver	30	60	1000	550	300	120	75	62
	40	60	770	385	215	90	70	62
	40	75	1000	610	360	140	95	80
	50	90	1000	800	460	195	115	105
	60	100	1000	840	485	200	120	110
	75	125	1000	1000	580	225	145	132
	30-60	125	1000	1000	820	340	180	133
Yellow	50	100	1000	840	485	197	115	110
	50	150	1000	1000	970	400	231	166
	60	100	1000	830	475	193	115	110
	60	150	1000	1000	920	380	220	160
	75	125	1000	1000	580	225	145	132
	75	185	1000	1000	1000	490	285	200
	100	150	1000	1000	650	270	185	157
	100	225	1000	1000	1000	500	320	240
Red	75	175	1000	1000	800	300	220	184
	100	200	1000	1000	900	350	250	210
	120	250	1000	1000	1000	480	315	263
	150	285	1000	1000	1000	500	350	300

*Note: Table body is the maximum inlet pressure that will allow the outlet pressure to stay below the value in the maximum outlet pressure during a wide-open failure situation.

POINT OF RELIEF DIFFERENTIAL PRESSURE DATA

Orifice Diff. Pressure PSIG	Outlet Pressure PSIG without Spring					
	Orifice Size (inches)					
	3/32*	1/8	3/16	1/4	3/8	1/2
50	0.5	1.0	1.5	1.5	2.0	4.0
100	0.5	1.0	1.5	2.0	2.5	7.5
200	1.0	1.5	2.5	3.5	5.0	12.5
300	2.0	2.5	4.0	5.5	8.0	20.0
400	3.0	3.5	5.5	7.5	11.5	-
500	3.5	4.5	7.5	9.5	15.0	-
600	4.0	5.5	9.5	12.0	19.0	-
700	4.5	6.5	11.5	14.5	-	-
800	5.0	7.5	14.0	17.0	-	-
900	5.5	8.0	16.0	19.5	-	-
1000	6.0	9.0	18.0	-	-	-

*Use the 3/32" orifice data for the 1/16" x 3/32" orifice.

B35R recommended maximum differential pressure above heavy line.

B35N recommended maximum differential pressure, as listed.

Relief Valve Spring = 14 PSIG less outlet pressure without adjusting spring. Add the remaining relief valve spring power to the adjusted outlet pressure. (For example, 400 PSI inlet to 100 PSI outlet, 1/4" orifice. $400 - 100 = 300$ PSI differential pressure from above chart, 300 PSI 1/4" orifice gives 5.5 PSI outlet. $14 - 5.5 = 8.5$ PSI when added to 100 PSI outlet pressure, point of relief is 108.5 PSIG.)

OPERATOR AND MONITOR INSTALLATION

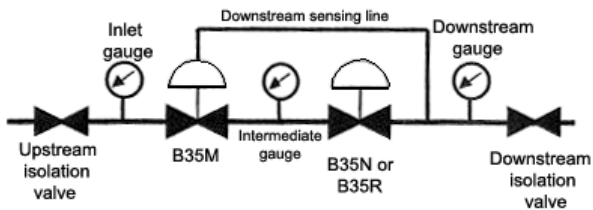

REGULATOR FIELD RELIEF VALVE TEST, CAP ASSEMBLY

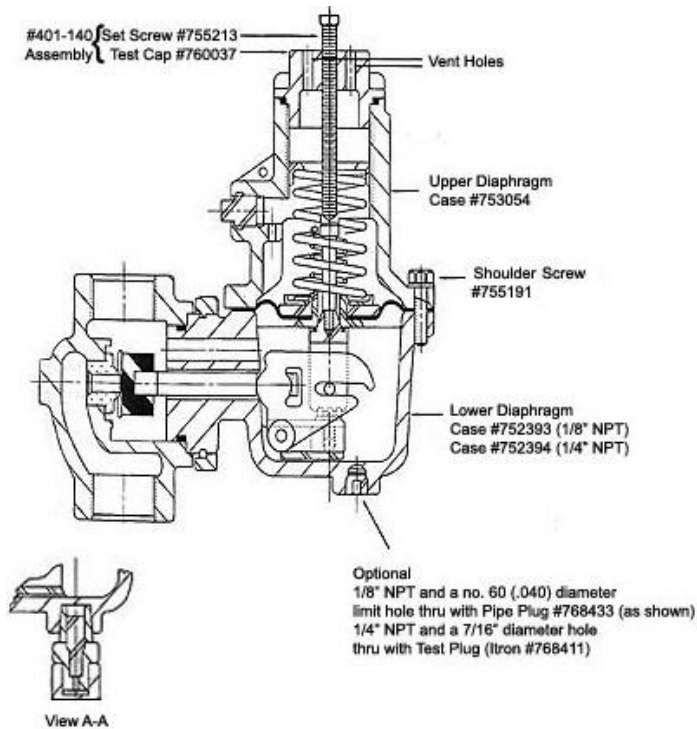

INSTRUCTIONS

1. Lower Diaphragm Case
 - a. Supplied with a 1/8" pipe plug. Remove the pipe plug and fasten the pressure gauge to the boss.
 - b. Supplied with a 1/4" universal seal test plug. Remove the closing cap on plug. Insert a gauge with the needle exposed. Fasten the pressure gauge to the plug.
2. Remove the vent cap from the upper diaphragm case and insert a special test cap (assembly number 799073).
3. Turn the adjustment set screw clockwise until the screw makes contact with the relief valve shoulder screw.
4. Continue to turn the adjustment set screw clockwise until a small volume of gas relieves from the vent holes.
5. Read the pressure gauge for the point of relief.
6. Turn the adjustment set screw counterclockwise until it reseals.
7. Check the vent holes with soapy water to verify there are no leaks.

ASSEMBLY POSITIONS

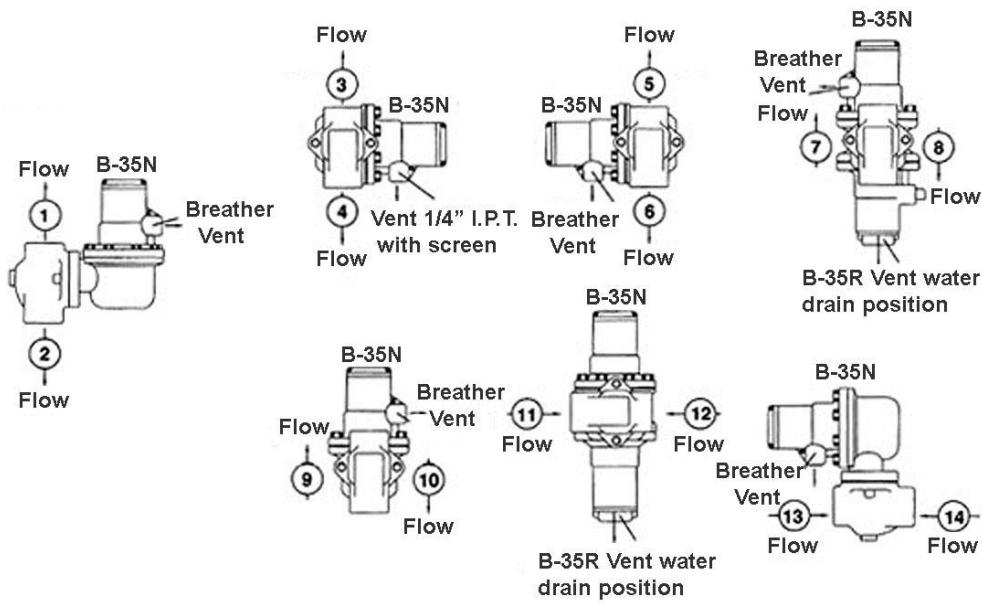

Shown: 14 basic B35 assembly positions.

Please specify the assembly position by number when ordering.

B35 REGULATORS R, N AND M MODELS PARTS DIAGRAM SCHEMATIC

B35N

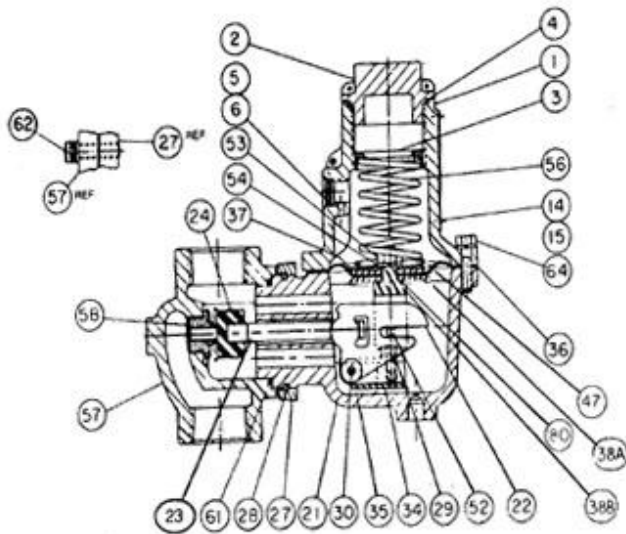

B35M

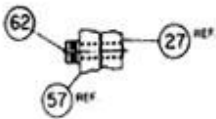

B35R

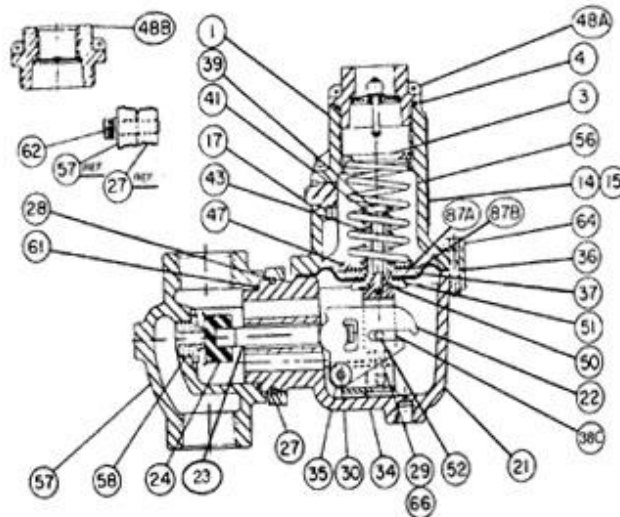

Torque Specifications	
Retainer plate screws	85 - 115 inch-pounds
Orifice cartridge	450 - 500 inch-pounds
Margin screws	50 - 80 inch-pounds

B35 PARTS LIST

Item Number	Part Number	Quantity Required per Regulator Model			Description
		N	R	M	
1					Upper diaphragm case, please specify
	753064	1	1	1	Vent, 1/4" pipe
	710042	1	1		Upper diaphragm case with items 5 & 6
	710043			1	Upper diaphragm case with item 17
2	760035	1	1		Seal cap
3	760201	1	1	1	Adjustment screw
4	765603	1	1	1	Seal cap gasket
5	762911	1	1		Vent screen, wire mesh
6	755773	1	1		Vent screen retainer ring
14	769241	1	1	1	Regulator badge
15	755071	2	2	2	Badge drive screw
17	768421			1	Upper diaphragm case pipe plug, 1/4" - 1/8" NPT
21			1	1	Lower diaphragm case, please specify
	752034				Not tapped
	752037				1/8" NPT pipe plug for 768431
	752040				1/4" NPT pipe plug for 768435 for 1/4" NPT test plug (R model only) 768411
	752043	1			Closed throat (M model only)
22	761226			1	Valve linkage lever
	761221	1	1		Valve linkage lever
23	754061		1	1	Valve stem, steel
	754064		1	1	Valve stem, stainless steel, specify
	754071	1			Valve stem, stainless steel
24	765235	1	1	1	Valve seat assembly, Urethane 95A, Duro
27	751953	1	1	1	Valve body retainer plate
28	755725	1	1	1	Retainer plate snap ring
29	755301	2	2	2	Valve linkage pin screw
30	754841	1	1	1	Valve linkage pin
30	754201	1			Valve stem bushing
32	754081	1			Valve stem adapter
33	765527	1			Valve stem O-ring
34	761901	1	1	1	Lever pin retainer
35	755803	2	2	2	Lever pin washer
36					Diaphragm, please specify
	766021	1	1		5/16" I.D.
	766023			1	Diaphragm, 5/8" I.D.
37					Upper diaphragm plate
	761015	1	1		Upper diaphragm plate B35N
	761011			1	Upper diaphragm plate B35R
					Lower diaphragm plate
38A	756005	1	1		Diaphragm plate screw B35R
38B	756031	1	1		Lower diaphragm plate B35M & N
38C	756035			1	Lower diaphragm plate B35R
39	755191			1	Stop stem

Item Number	Part Number	Quantity Required per Regulator Model			Description
		N	R	M	
41	761411			1	Relief spring guide
43	762085			1	Relief spring
47					Adjustment spring guide
	761431	1	1		Diaphragm plate spring guide B35N
	761421			1	Diaphragm plate spring guide B35R
48				1	Vent cap assembly, please specify
A	730002				Non-piped with ball indicator
B	730001				piped
50	765711			1	Internal relief valve seal gasket, Buna "N"
51	756005			1	Diaphragm plate screw
52	755001	1	1		Rollpin, 3/16" D. x 3/4" Lg., steel
53	755531	1	1		Diaphragm nut, hex 5/16" - 18, steel
54	755851	1	1		Diaphragm plate split lock washer for 5/16" - 18, steel
56		1	1	1	Adjustment spring, please specify color
	762403				Green
	762415				Orange
	762417				Green/white
	762419				Blue/white
	762409				Silver
	762411				Yellow
	762413				Red
57		1	1	1	Valve body, please specify size
	750504				3/4" x 3/4" NPT
	750507				3/4" x 1" NPT
	750510				1" x 1" NPT
58		1	1	1	Orifice, please specify size
	757081				1/16" x 3/32" D., stainless steel
	757082				3/32" D., stainless steel
	758531				1/8 D., brass
	758541				1/8" D, stainless steel
	758532				3/16" D., brass
	758542				3/16" D, stainless steel
	758533				1/4" D., brass
	758543				1/4" D., stainless steel
	758535				3/8" D., brass
58		1	1	1	Orifice, please specify size
	758545				3/8" D., stainless steel
	758536				1/2" D., brass
	758546				1/2" D., stainless steel
61	765605	1	1	1	Valve body gasket, Buna "N"
62		2	2	2	Retainer plate screw soc. hd. cap screw, please specify
	755171				5/16" - 1-1/8" x1" Lg., steel
	755173				5/16" - 1-1/8" x 1" Lg., stainless steel
64		8	8	8	Case screw
	755205				Torx hd. 1/4" - 20" x1 lg., steel
	755180				Allen hd. 1/4" - 20" x 1", lg., stainless steel

Item Number	Part Number	Quantity Required per Regulator Model			Description
		N	R	M	
66	755853				Valve linkage pin screw lock washer
87A	755821			1	Anti-friction washer
87B	755823			1	Anti-friction washer

Part Number	Special Tools
799073	Test assembly, field use
760049	Vent protector for N
720031	R diaphragm assembly
720030	M,N diaphragm assembly

Seal Caps, 3 Types

Cast Iron, Internal Relief Valve (B35R)	No vent pipe attachment. Contains stainless steel spiral vent screen plated steel guide. Install vent down for complete water drain. A red indicator ball stays out after relief valve functions. Indicator ball is reset manually.
Cast Iron, Internal Relief Valve (B35R)	For 3/4" vent pipe attachment. Similar to above cap, with 3/4" NPT vent tap and without spiral vent or indicator ball.
No Relief (B35N)	Solid cap.

VENT LINES FOR REGULATORS

When you are constructing vent lines to attach to regulators installed indoors, follow a few basic rules:

- a. Never use pipe sizes smaller than the vent size; smaller pipe sizes restrict the gas flow. If a long gas run must be used, Itron advises increasing the pipe one nominal size every ten feet to keep the flow restriction as low as possible.
- b. Keep the vent line length as short as possible to minimize the restriction and reduce the vent's tendency to cause regulator pulsation.
- c. Support the vent pipe to eliminate strain on the regulator diaphragm case.
- d. Always point outdoor vent pipes in the downward position to reduce the possibility of rain, snow, sleet, and other moisture entering the pipe. Install a bug screen in the end of the pipe.
- e. Do not locate the vent line terminus near windows, fans, or other ventilation equipment. See the installation instructions furnished with the regulator.
- f. Adhere to all applicable codes and regulations.
- g. If your vent pipe causes regulator pulsation, consult your sales representative or manufacturer.
- h. Itron strongly recommends running a separate vent line for each regulator. Headers with various installed devices can cause regulator malfunction.

Caution Ensure the end of the vent line is away from ANY potential ignition sources. It is the installer's responsibility to ensure the vent line is exhausting to a safe environment.

INSTALLATION

Warning Itron does not endorse or warrant the completeness or accuracy of any third party regulator installation procedures or practices, unless otherwise provided in writing by Itron. Follow your company's standard operating procedures regarding the use of personal protection equipment (PPE). Adhere to guidelines issued by your company in addition to those given in this document when installing regulators.

- a. Remove all shipping plugs from the regulator inlet, outlet, and vent before installation.
- b. Verify the piping interior and regulator inlet and outlet are clean and free of dirt, pipe dope, and other debris. Dirt and other foreign materials entering the regulator can cause a loss of pressure control.
- c. Apply pipe joint sealant to the male pipe threads. Do not use pipe joint material on the regulator's female threads. Joint sealant could become lodged in the regulator and cause a loss of pressure control.
- d. Gas must flow through the regulator's valve body in the direction cast on the regulator body. Gas flowing in the wrong direction can overpressure and cause damage to the regulator.
- e. The pilot diaphragm casing can be mounted in any position relative to the body through a full 360° angle at 90° increments.
- f. When the regulator is installed OUTDOORS, the vent must always be positioned so that rain, snow, moisture or foreign particles cannot enter the vent opening. Itron recommends positioning the pilot vent downward to avoid entry of water or other matter which could interfere with the proper operation of the regulator. The vent should be located away from building eaves, window openings, building air intakes and above the expected snow level at the site. The vent opening should be inspected periodically to insure it does not become blocked by foreign material as outlined in DOT PHMSA-RSPA-2004-19856.
- g. When the regulator is installed INDOORS, the vent must be piped to the outside atmosphere using the shortest length of pipe, the fewest possible pipe elbows, and a pipe diameter as large as the vent size or larger. USING VENT PIPE SMALLER THAN THE VENT CONNECTION LIMITS THE REGULATOR'S INTERNAL RELIEF VALVE CAPACITY. The outlet end of the pipe must be protected from moisture and the entrance of foreign particles. The regulator should be specified by the user with the size vent and pipe threads desired to make the vent pipe connection.

START-UP PROCEDURE

- a. Mount a pressure gauge downstream of the regulator to monitor the downstream pressure.
- b. With the downstream pressure valve closed, slowly open the inlet valve. The outlet pressure should rise to slightly more than the set-point. Verify there are no leaks and all connections are tight.
- c. The regulator was pre-set at the factory to match order specifications. If necessary, adjust the outlet pressure by removing the seal cap on the top of the pilot spring housing and adjusting the ferrule or screw inside the pilot spring housing using a large flat-head screwdriver. With a small amount of gas flowing through the regulator, rotate the pilot ferrule clockwise to raise the outlet pressure or counter-clockwise to lower the outlet pressure.
- d. Replace the seal cap and check for leaks after the desired outlet pressure is achieved.

The regulator is ready for operation.

SAFETY WARNING

This product, as of the date of manufacture, is designed and tested to conform to all governmental and industry safety standards as they may apply to the manufacturer. The purchaser/user of this product must comply with all fire control, building codes, and other safety regulations governing the application, installation, operation, and general use of this regulator to avoid leaking gas hazards resulting from improper installation, startup or use of this product.

Itron strongly recommends installation by a qualified professional and periodic inspection of pressure regulators (inspections may be required by local applicable codes or regulations).

Inspections should include checking for gas quality, cycle numbers, external environmental changes, and operating conditions that impact wear on the regulator's moving parts. To ensure safe and efficient operation of this product, replace worn or damaged parts found during inspection.

The maximum inlet pressure for this regulator is dependent on the orifice size and model designation. The non -relief models are limited to 60 PSIG maximum inlet pressure unless additional safety devices are used as outlined in DOT code, OPS, Part 192, section 192.197. When these B35 Series regulators are used on petroleum gases, they should be restricted to second-stage pressure reduction in the gaseous phase.

LIMITED WARRANTY

Itron, Inc. 970 Highway 127 North, Owenton, Kentucky 40359-9302, warrants this gas product against defects in materials and workmanship for the earlier of one (1) year from the date the product is shipped by Itron or a period of one year from the date the product is installed by Itron at the original purchaser's site. During such one-year period, provided that the original purchaser continues to own the product, Itron will, at its sole option, repair any defects, replace the product or repay the purchase price.

» This warranty will be void if the purchaser fails to observe the procedures for installation, operation or service of the product as set forth in the Operating Manual and Specifications for the product or if the defect is caused by tampering, physical abuse or misuse of the product.

- » ITRON SPECIFICALLY DISCLAIMS ALL IMPLIED WARRANTIES INCLUDING THOSE OF MERCHANTABILITY OR OF FITNESS FOR A PARTICULAR PURPOSE. UNDER NO CIRCUMSTANCES WILL ITRON BE LIABLE FOR INCIDENTAL OR CONSEQUENTIAL DAMAGES OF ANY KIND WHATSOEVER.
- » Itron's liability for any claim of any kind, including negligence and breach of warranty for the sale and use of any product covered by or furnished, shall in no case exceed the price allocable to the product or part thereof which gives rise to the claim.
- » In the event of a malfunction of the product, consult your Itron Service Representative or Itron Inc., 970 Highway 127 North, Owenton, Kentucky 40359-9302. See Itron Terms and Conditions of Sale for the full and complete terms of the Limited Warranty.

ORDERING INFORMATION

Specify:

1. Inlet and Outlet Connection Size and Type
2. Model Number
3. Outlet pressure desired
4. Pilot needed
5. Inlet pressure range
6. Type of gas and maximum capacity required
7. Assembly position number (see chart below)
8. Special requirements such as tagging, 1/8" pipe plug tap, seal wire, etc.



At Itron, we're dedicated to delivering end-to-end smart grid and smart distribution solutions to electric, gas and water utilities around the globe. Our company is the world's leading provider of smart metering, data collection and utility software systems, with over 8,000 utilities worldwide relying on our technology to optimize the delivery and use of energy and water.

To realize your smarter energy and water future, start here: www.itron.com

CORPORATE HEADQUARTERS

2111 N Molter Road
Liberty Lake, WA 99019
USA

Phone: 1.800.635.5461

Fax: 1.509.891.3355

While Itron strives to make the content of its marketing materials as timely and accurate as possible, Itron makes no claims, promises, or guarantees about the accuracy, completeness, or adequacy of, and expressly disclaims liability for errors and omissions in, such materials. No warranty of any kind, implied, expressed, or statutory, including but not limited to the warranties of non-infringement of third party rights, title, merchantability, and fitness for a particular purpose, is given with respect to the content of these marketing materials. © Copyright 2012, Itron. All rights reserved. 101068SP-02 01/12