



B36 R, N, & M

High Pressure Service Regulator

The B36 is a pounds to pounds reducing regulator for inlet pressures up to 175 PSIG and outlet pressures from 1 to 60 PSIG. Designed for use where two stage reduction applications are required.

DESCRIPTION

The light weight compact unit is ideally suited for suburban taps, industrial and other installations requiring this type of regulator. The malleable iron retainer plate and "O" ring seal allows the valve body and diaphragm case to be installed in any 360 degree position. The vent must always face downward, in the water drain position when installed outdoors.

RELIEF VALVE CHARACTERISTICS

The internal relief valve of the B36 adds built in safety to a well established regulator. The relief valve is separated from the diaphragm clamping and maintains a guided, positive alignment with the "O" ring seat. The B36 relief valve combines a large throat opening, a relief valve and a large relief capacity. The vent is a 3/4" NPT with stainless steel screen and complete water drain when installed pointing downstream.

BENEFITS

- » Economical
- » Heavy duty construction with a cast iron body
- » Corrosion Resistant
- » Inlet pressure capabilities up to 175 PSIG
- » No special start up procedures
- » Polyurethane seat ensures reliable "lockup" (up to 175 PSIG inlet pressure)
- » Outlet pressure capabilities of 1 to 60 PSIG
- » Maximum flow capacities up to 10,000 SCFH
- » Controlled breather orifice size eliminates pulsation and provides normal actuation at low flows

FEATURES

- » Easy field servicing
- » Interchangeable brass orifice
- » Spring-loaded internal relief valve assembly
- » Field interchangeable adjustment spring
- » 3/4" NPT, 1" NPT, and 1-1/4" NPT valve bodies available
- » 90 degree valve body also available
- » 16 different assembly positions
- » Controlled boost
- » Ideal for suburban tap and industrial applications

SHIPPING WEIGHT

12 regulators per box Box weight: 86 lbs.

B36 DIMENSIONS (INCHES)

Valve Body	A	B	C	D	E	F	G
3/4 and 1	3-3/4	2-1/8	4-7/8	4-7/8	2-5/8	5-1/2	2-1/4
1-1/4	4	2-1/8	4-7/8	4-7/8	2-5/8	5-1/2	2-1/4
3/4 and 1 90°		1-5/8	4-7/8	4-7/8	2-5/8	5-1/2	2-1/4

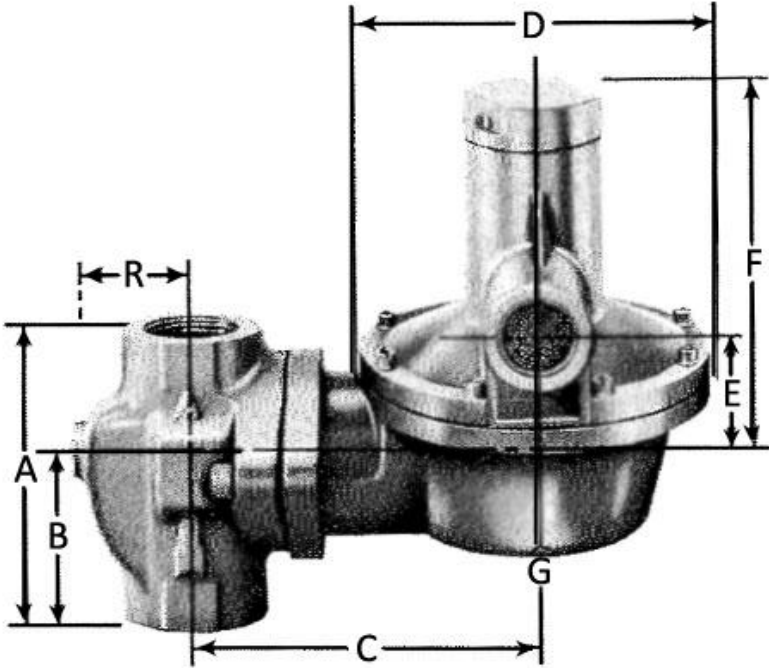

OPERATIONAL SCHEMATIC

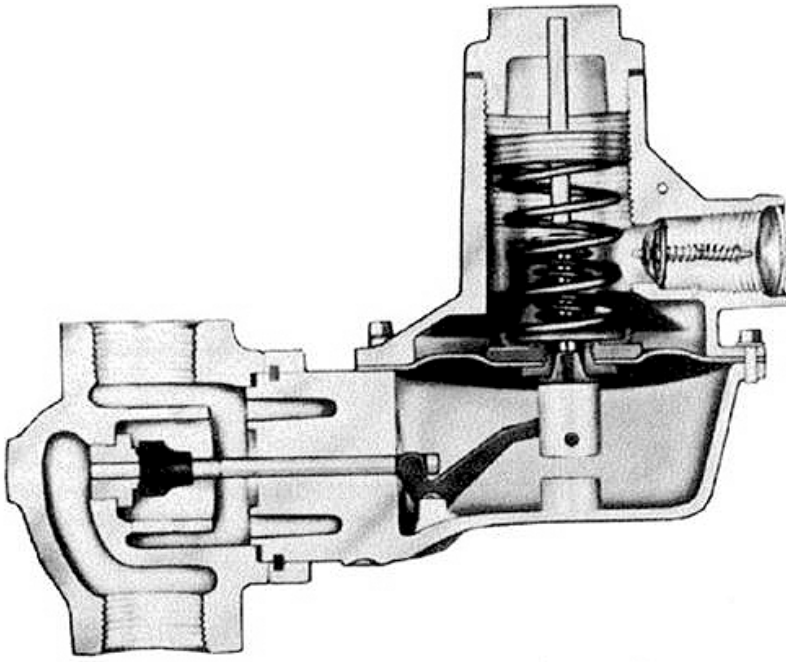

Note Valve shown in closed position.

SPRING DATA, SPRING COLOR OUTLET PRESSURE RANGE

Outlet Pressure Range (PSIG)

B36 Spring Color	Basic	Adjustment (1)
Brown	1-2	.75 to 2.5
Green	5	1.5 to 10
Black	10	5 to 14
Blue	15-20-25	9 to 30
Silver	30-40-60	25 to 60

Relief Spring

B36 Relief Spring Color	Field (2)	Back Press (3)
Brown	1.5	.5
Green	4.0	1.5
Black	10.0	1.5
Blue		3.0
Silver		11.0

1. Adjustment range determined using regulator mounted in position No. 5, 25 PSIG minimum inlet to maximum inlet per orifice.
2. Relief pressure above spring set. Add outlet pressure to relief spring value for true field relief.
3. If back pressure method is used for shop test, add outlet pressure to relief spring value and back pressure of main spring.

MAXIMUM ALLOWABLE OPERATING PRESSURE

Orifice Size (Inches)	Maximum Operating Inlet (PSIG)
1/8	175
3/16	175
1/4	150

OPERATING TEMPERATURE RANGE

- -20°F to 150°F

ADDITIONAL SPECIFICATIONS

Available Vent Sizes:	3/4"
Other Available Options:	Seal wire to indicate unapproved tampering
	1/8" pipe plug tap on upstream side of valve body

CONSTRUCTION

Itron takes pride in delivering American made products with the utmost concern for safety, quality, and customer satisfaction.

Construction material

Valve body	Cast iron ASTM A 126
Orifice	Brass
Valve seat	Buna-N
Valve stem	Aluminum
Lever pin	Stainless steel
Lever	Zinc plated steel
Upper diaphragm plate	Zinc plated steel
Lower diaphragm plate	Zinc plated steel
Diaphragm	Nylon reinforced nitrile
Vent valve/seat	Zinc plated steel
Vent screen	Stainless steel
Adjustment ferrule	Zinc plated steel
Seal cap	Cast iron
Diaphragm case	Die-cast aluminum
Fastener plating	Dacromet

VALVE BODY SIZES

Inlet	Outlet	90 Angle
3/4"	3/4"	X
	1"	X
	1-1/4"	-
1"	1"	X
	1-1/4"	-
1-1/4"	1-1/4"	-

Note X -indicates that the valve body is available in that configuration.

CORRECTION FACTORS FOR NON-NATURAL GAS APPLICATIONS

The B36 may be used to control gases other than natural gas. To determine the capacity for gases other than natural gas, multiply the values within the capacity tables by a correction factor. The table below lists the correction factors for some of the more common gases:

Gas Type	Specific Gravity	Correction Factor (CF)
Air	1.00	0.77
Butane	2.01	0.55
Carbon Dioxide (Dry)	1.52	0.63
Carbon Monoxide (Dry)	0.97	0.79
Natural Gas	0.60	1.00
Nitrogen	0.97	0.79
Propane	1.53	0.63
Propane-Air-Mix	1.20	0.71

To calculate the correction factor for gases not listed in the table above, use the gases' specific gravity and insert it in the formula listed below:

$$\text{Correction Factor (CF)} = \sqrt{\frac{SG_1}{SG_2}}$$

Where:

SG_1 = Specific gravity of the gas in which the capacity is published.

SG_2 = Specific gravity of the gas to be controlled.

Wide Open Flow Calculations

For wide-open orifice flow calculations use the following equations:

$$\text{For } \frac{P_1}{P_2} < 1.89 \text{ use: } Q = K\sqrt{P_2(P_1 - P_2)}$$

$$\text{For } \frac{P_1}{P_2} > 1.89 \text{ use: } Q = \frac{KP_1}{2}$$

Where: P_1 = Absolute Inlet Pressure (PSIA)

P_2 = Absolute Outlet Pressure (PSIA)

Q = Flow Rate (SCFH)

K = Orifice Coefficient (SCFH/PSI)

B36 SERIES HIGH PRESSURE SERVICE REGULATOR

Capacity Table (10% Absolute Gauge Droop)

Capacity, SCFH, 0.6 S.G. gas; 14.7 PSIA 10% outlet pressure change and maximum orifice.¹

Typical Capacity Info.	
Manufacturer	Itron
Type and model	B36
Regulator	
Spring color	Varies

1. Regulator set for inlet pressure and outlet pressure when flowing 200 SCFH 0.6 S.G. gas. The above capacity table is based on a 10% change in outlet pressure from set. The capacity is a direct function of spring rate. For other percent change in outlet pressure, use the Capacity Table in direct proportion up to the maximum orifice capacity.

(For example, inlet 175 PSIG; orifice 1/8"; outlet 25 PSIG.)

A 10% drop in outlet pressure equals 2.5 PSIG. This results in an actual outlet pressure of 22.5 PSIG at 1900 SCFH capacity.)

(For maximum capacity of 2800 SCFH, the outlet pressure is determined as follows:

$1900/10\% = 2800/x \times 14.7\% \times 25 \text{ PSIG} = 3.7 \text{ PSIG}$

At a maximum capacity of 2800 SCFH, the actual outlet pressure will be 21.3 PSIG [25 - 3.7]).

Inlet Pressure (PSIG)	Outlet Pressure (PSIG & Spring)	Orifice Size					
		1/8 Maximum 10%		3/16 Maximum 10%		1/4 Maximum 10%	
20	5 Green	375	500	475	1200	625	2000
	10 Black	430	470	425	1100	725	1900
	15 Blue	325	360	460	850	600	1450
40	5 Green	575	825	725	1950	900	3350
	10 Black	660	825	775	1950	1325	3350
	15 Blue	700	825	850	1925	1125	3300
	20 Blue	750	800	950	1875	1400	3200
	25 Blue	700	725	1000	1725	1450	2950
60	30 Silver	475	625	575	1500	600	2575
	5 Green	700	1125	800	2650	850	4550
	10 Black	750	1125	1100	2650	1325	4550
	15 Blue	900	1125	1025	2650	1225	4550
	20 Blue	1075	1125	1325	2650	1625	4550
	25 Blue	1075	1125	1375	2650	1700	4550
75	30 Silver	500	1100	700	2600	1075	4450
	40 Silver	675	1000	825	2350	1175	4000
	5 Green	875	1300	975	3100	1000	5300
	10 Black	1100	1300	1225	3100	1600	5300
	15 Blue	1050	1300	1225	3100	1500	5300
	20 Blue	1250	1300	1475	3100	1700	5300
	25 Blue	1300	1300	1750	3100	2050	5300
100	30 Silver	775	1300	800	3100	1075	5300
	40 Silver	825	1300	1025	3100	1300	5300
	60 Silver	875	1000	1100	2300	1600	4000
	5 Green	1025	1700	1200	4000	1300	6900
	10 Black	1500	1700	1300	4000	1900	6900
	15 Blue	1325	1700	1475	4000	1850	6900
	20 Blue	1550	1700	1875	4000	2300	6900
175 Max. 1/8 and 3/16 150 Max. 1/4	25 Blue	1700	1700	2275	4000	2600	6900
	30 Silver	925	1700	1100	4000	1450	6900
	40 Silver	1075	1700	1400	4000	1875	6900
	60 Silver	1100	1600	1450	3800	2150	6500
	5 Green	1375	2800	1500	6700	1275	10000
	10 Black	1725	2800	1850	6700	2275	10000
	15 Blue	1450	2800	2100	6700	1925	10000
	20 Blue	1525	2800	2250	6700	2650	10000
25 Blue	1900	2800	2525	6700	2700	10000	
30 Silver	1120	2800	1300	6700	1375	10000	
40 Silver	1475	2800	1875	6700	2075	10000	
60 Silver	1950	2800	2300	6700	2800	10000	

*Individual regulator performance may vary from data shown.

RELIEF VALVE PRESSURE DATA AND VENT CAPACITY

Regulator Set Outlet, PSIG		5	10	15	20	25	30	40	60
Orifice (inches)	Inlet Pressure (PSIG)	Maximum Outlet Pressure, PSIG Vent Capacity, SCFH							
		1/8	60	14	20	15	33	39	55
	1120		1120	1120	1120	1120	600	---	---
100	17		23	30	36	41	59	69	89
	1700		1700	1700	1700	1700	1700	1650	1100
175	22		28	36	41	46	65	75	95
	2800	2800	2800	2800	2800	2800	2800	2800	2800
3/16	60	20	25	33	38	42	57	---	---
		2650	2650	2650	2650	2650	1080	---	---
	100	26	32	39	45	50	68	77	94
		4000	4000	4000	4000	4000	3800	3400	1850
	175	41	47	55	59	64	86	92	111
	6700	6700	6700	6700	6700	6700	6700	6500	6200
1/4	40	22	26	33	36	39	---	---	---
		3340	2900	2500	1750	900	---	---	---
	75	33	39	45	49	53	67	71	---
		5300	5300	5300	4950	4700	3100	2260	---
	150	63	65	72	77	83	100	110	122
	10000	10000	9800	9600	9400	9100	8600	7550	
Red Spring		Green	Black	Blue	Blue	Blue	Silver	Silver	Silver

Note Relief test (regulator set for outlet pressures), then valve seat removed. The green relief spring (4 PSIG) was used on all tests. The additional pressure build-up before point of relief is due to the increased compression of the main spring as the diaphragm lifts to the safety stop position.

B36 PERFORMANCE CURVES

10 PSIG Set Point

Type and model	B36R
Vent size	3/4"

All test results are reported at a base of 14.7 PSIA at 60° F and with 0.6 S.G. gas.

Regulator set using 10 PSIG outlet pressure with 60 PSIG inlet pressure – 200 SCFH.

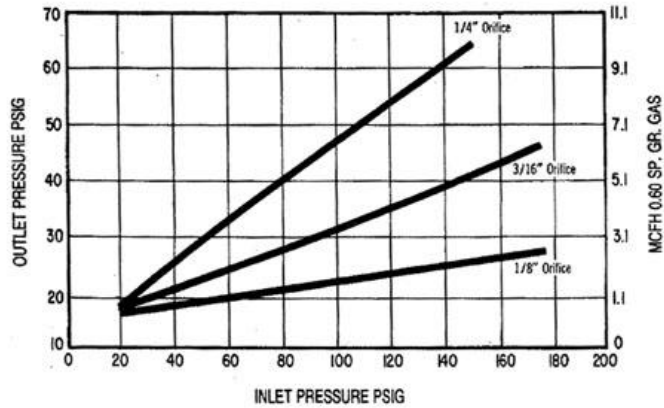

ASSEMBLY POSITIONS

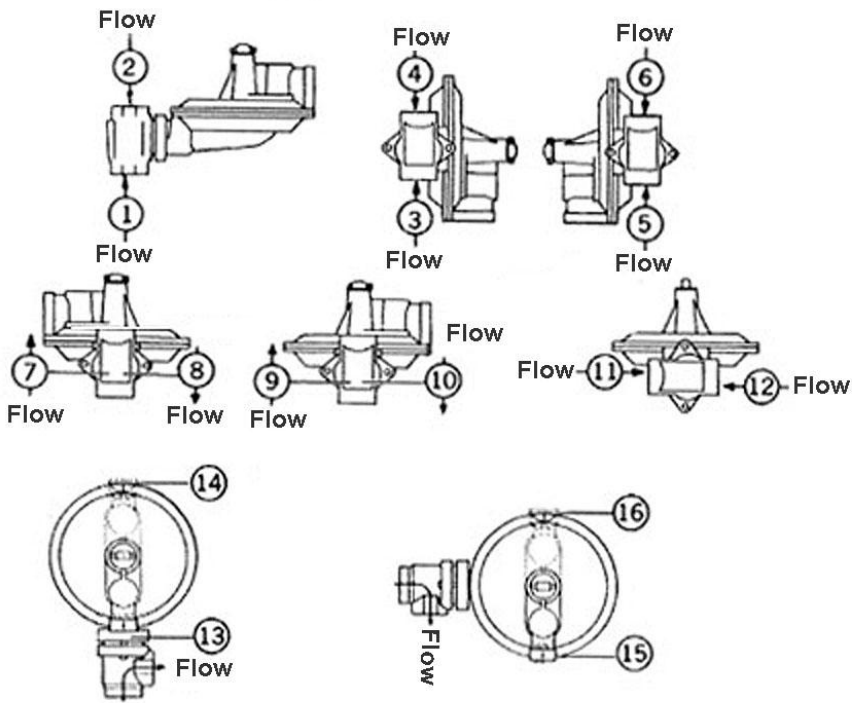

Positions 13 through 15 achieved with 90° angle body.

B36 PARTS DIAGRAM SCHEMATIC

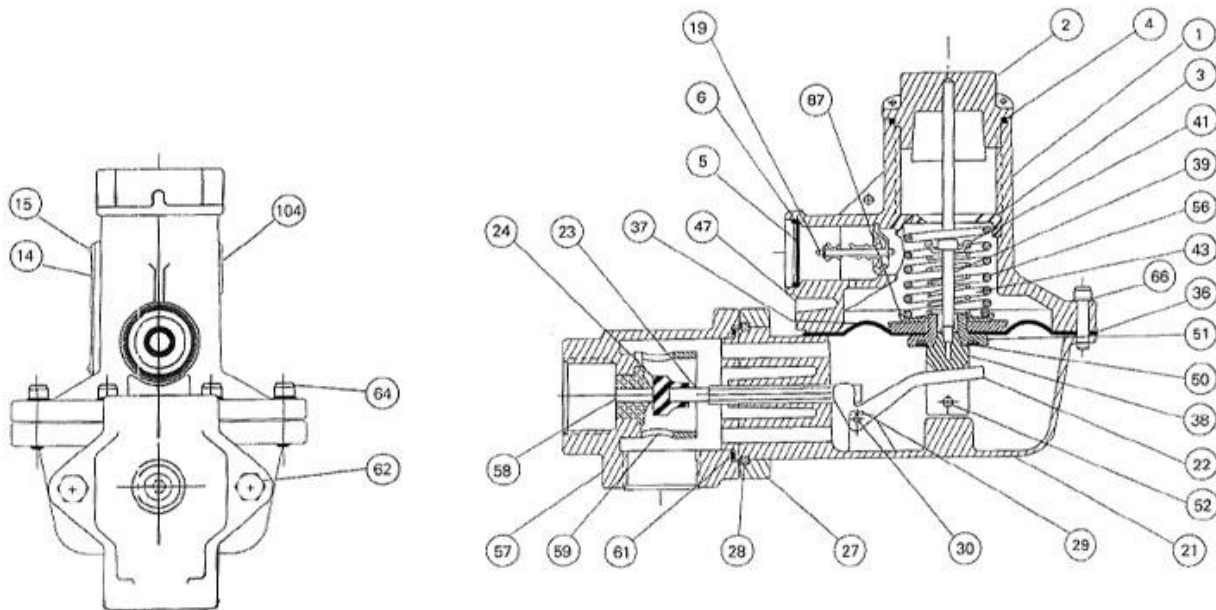

B36 PARTS LIST

Item Number	Part Number	Quantity per Regulator	Description
1	753044	1	Upper diaphragm case with 3/4" vent
2	730003	1	Seal cap assembly
3	760201	1	Adjustment screw
4	765603	1	Seal cap gasket
5	762905	1	Vent screen -spiral
6	755727	1	Vent screen retaining ring
14	769241	1	Regulator badge
15	755071	2	Badge drive screw
19	730101	1	Vent valve assembly
21	752055	1	Lower diaphragm case
22	761021	1	Valve linkage lever
23	754021	1	Valve stem, aluminum
24	765021	1	Valve seat -Buna "N" 75 D
27	751955	1	Valve body retainer plate
28	755725	1	Retainer plate snap ring
29	755141	2	Valve linkage pin screw
30	754831	1	Valve linkage pin
36	766031	1	Diaphragm
37	761011	1	Upper diaphragm plate
38	756001	1	Lower diaphragm plate
39	755193	1	Stop stem, steel
41	761411	1	Relief spring guide
43	762083	1	Green 4.0 PSIG relief spring
47	761421	1	Adjustment spring guide
50	765711	1	Valve seal gasket
51	756005	1	Diaphragm plate screw
52	755001	1	Rollpin
56		1	Adjustment spring, please specify
	762401		Brown .75 - 2.5 PSIG
	762403		Green 1.5 - 10.0 PSIG
	762405		Black 5 - 14 PSIG
	762407		Blue 9 - 30 PSIG
	762409		Silver 25 - 60 PSIG
57		1	Valve body, specify type <i>straight</i> & size
	750054		3/4" x 3/4" with 1/8" NPT pipe plug
	750057		3/4" x 3/4"
	750063		3/4" x 1" with 1/8" NPT pipe plug
	750065		3/4" x 1"
	750072		1" x 1" with 1/8" NPT pipe plug
	750075		1" x 1"
	750104		3/4" x 1"-1/4" with 1/8" NPT pipe plug
	750107		3/4" x 1"-1/4"
	750113		1" x 1"-1/4" with 1/8" NPT pipe plug
	750116		1" x 1"-1/4"
	750128		1"-1/4" x 1"-1/4"
	750131		1"-1/4" x 1"-1/4" with 1/8" NPT pipe plug

Item Number	Part Number	Quantity per Regulator	Description
			Valve body, specify type <i>90° angle body</i> and size
	750042		3/4" x 3/4"
	750044		3/4" x 1"
	750046		1" x 1"
58		1	Orifice, brass, please specify size
	757255		1/8" diameter
	757259		3/16" diameter
	757263		1/4" diameter
	757267		5/16" diameter
	757271		3/8" diameter
	757461		1/2" diameter
59	761753	1	Loading ring
61	765753	1	Valve body gasket
62	755371	2	Retainer plate screw steel, cadmium plate Hex Hd., 5/16 - 18 x 1 - 1/8" Lg.
64	755175	8	Case screw, Soc. Hd. #10 - 24 x 7/8" Lg. steel cadmium plate
66	755855	8	Lock washer
87	755821	1	Anti-friction washer

Torque Specifications

Margin screws	50 - 60 in. lbs.
Retainer plate screws	85 - 115 in. lbs.
Orifice	450 - 500 in. lbs.

VENT LINES FOR REGULATORS

When constructing vent lines to be attached to regulators installed indoors, follow a few basic rules:

- a. Never use pipe sizes smaller than the vent size; smaller pipe sizes restrict the gas flow. If a long gas run must be used, Itron advises increasing the pipe one nominal size every ten feet to keep the flow restriction as low as possible.
- b. Keep the vent line length as short as possible to minimize the restriction and reduce the vent's tendency to cause regulator pulsation.
- c. Support the vent pipe to eliminate strain on the regulator diaphragm case.
- d. Always point outdoor vent pipes in the downward position to reduce the possibility of rain, snow, sleet, and other moisture entering the pipe. Install a bug screen in the end of the pipe.
- e. Do not locate the vent line terminus near windows, fans, or other ventilation equipment. See the installation instructions furnished with the regulator.
- f. Adhere to all applicable codes and regulations.
- g. If your vent pipe causes regulator pulsation, consult your sales representative or manufacturer.
- h. Itron strongly recommends running a separate vent line for each regulator. Headers with various installed devices can cause regulator malfunction.

Caution Ensure the end of the vent line is away from ANY potential ignition sources. It is the installer's responsibility to ensure the vent line is exhausting to a safe environment.

INSTALLATION

Warning Itron does not endorse or warrant the completeness or accuracy of any third party regulator installation procedures or practices, unless otherwise provided in writing by Itron. Follow your company's standard operating procedures regarding the use of personal protection equipment (PPE). Adhere to guidelines issued by your company in addition to those given in this document when installing regulators.

- a. Remove all shipping plugs from the regulator inlet, outlet, and vent before installation.
- b. Verify the piping interior and regulator inlet and outlet are clean and free of dirt, pipe dope, and other debris. Dirt and other foreign materials entering the regulator can cause a loss of pressure control.
- c. Apply pipe joint sealant to the male pipe threads. Do not use pipe joint material on the regulator's female threads. Joint sealant could become lodged in the regulator and cause a loss of pressure control.
- d. Gas must flow through the regulator's valve body in the direction cast on the regulator body. Gas flowing in the wrong direction can overpressure and cause damage to the regulator.
- e. The pilot diaphragm casing can be mounted in any position relative to the body through a full 360° angle at 90° increments.
- f. When the regulator is installed OUTDOORS, the vent must always be positioned so that rain, snow, moisture or foreign particles cannot enter the vent opening. Itron recommends positioning the pilot vent downward to avoid entry of water or other matter which could interfere with the proper operation of the regulator. The vent should be located away from building eaves, window openings, building air intakes and above the expected snow level at the site. The vent opening should be inspected periodically to insure it does not become blocked by foreign material as outlined in DOT PHMSA-RSPA-2004-19856.
- g. When the regulator is installed INDOORS, the vent must be piped to the outside atmosphere using the shortest length of pipe, the fewest possible pipe elbows, and a pipe diameter as large as the vent size or larger. USING VENT PIPE SMALLER THAN THE VENT CONNECTION LIMITS THE REGULATOR'S INTERNAL RELIEF VALVE CAPACITY. The outlet end of the pipe must be protected from moisture and the entrance of foreign particles. The regulator should be specified by the user with the size vent and pipe threads desired to make the vent pipe connection.

START-UP PROCEDURE

- a. Mount a pressure gauge downstream of the regulator to monitor the downstream pressure.
- b. With the downstream pressure valve closed, slowly open the inlet valve. The outlet pressure should rise to slightly more than the set-point. Verify there are no leaks and all connections are tight.
- c. The regulator was pre-set at the factory to match order specifications. If necessary, adjust the outlet pressure by removing the seal cap on the top of the pilot spring housing and adjusting the ferrule or screw inside the pilot spring housing using a large flat-head screwdriver. With a small amount of gas flowing through the regulator, rotate the pilot ferrule clockwise to raise the outlet pressure or counter-clockwise to lower the outlet pressure.
- d. Replace the seal cap and check for leaks after the desired outlet pressure is achieved.

The regulator is ready for operation.

SAFETY WARNING

This product, as of the date of manufacture, is designed and tested to conform to all governmental and industry safety standards as they may apply to the manufacturer. The purchaser/user of this product must comply with all fire control, building codes, and other safety regulations governing the application, installation, operation, and general use of this regulator to avoid leaking gas hazards resulting from improper installation, startup or use of this product.

Itron strongly recommends installation by a qualified professional and periodic inspection of pressure regulators (inspections may be required by local applicable codes or regulations).

Inspections should include checking for gas quality, cycle numbers, external environmental changes, and operating conditions that impact wear on the regulator's moving parts. To ensure safe and efficient operation of this product, replace worn or damaged parts found during inspection.

The maximum inlet pressure for this regulator is dependent upon the size of the orifice and model designation. The non-relief models are limited to 60 PSIG maximum inlet pressure unless additional safety devices are used as outlined in DOT code, OPS, Part 192, section 192.197. When B36 models are used on liquid petroleum gases, they should be restricted to second-stage pressure reduction in the gaseous phase.

LIMITED WARRANTY

Itron, Inc. 970 Highway 127 North, Owenton, Kentucky 40359-9302, warrants this gas product against defects in materials and workmanship for the earlier of one (1) year from the date the product is shipped by Itron or a period of one year from the date the product is installed by Itron at the original purchaser's site. During such one-year period, provided that the original purchaser continues to own the product, Itron will, at its sole option, repair any defects, replace the product or repay the purchase price.

» This warranty will be void if the purchaser fails to observe the procedures for installation, operation or service of the product as set forth in the Operating Manual and Specifications for the product or if the defect is caused by tampering, physical abuse or misuse of the product.

- » ITRON SPECIFICALLY DISCLAIMS ALL IMPLIED WARRANTIES INCLUDING THOSE OF MERCHANTABILITY OR OF FITNESS FOR A PARTICULAR PURPOSE. UNDER NO CIRCUMSTANCES WILL ITRON BE LIABLE FOR INCIDENTAL OR CONSEQUENTIAL DAMAGES OF ANY KIND WHATSOEVER.
- » Itron's liability for any claim of any kind, including negligence and breach of warranty for the sale and use of any product covered by or furnished, shall in no case exceed the price allocable to the product or part thereof which gives rise to the claim.
- » In the event of a malfunction of the product, consult your Itron Service Representative or Itron Inc., 970 Highway 127 North, Owenton, Kentucky 40359-9302. See Itron Terms and Conditions of Sale for the full and complete terms of the Limited Warranty.

ORDERING INFORMATION

Specify:

1. Inlet and Outlet Connection Size and Type
2. Model Number
3. Outlet pressure desired
4. Pilot needed
5. Inlet pressure range
6. Type of gas and maximum capacity required
7. Assembly position number (see chart below)
8. Special requirements such as tagging, 1/8" pipe plug tap, seal wire, etc.



At Itron, we're dedicated to delivering end-to-end smart grid and smart distribution solutions to electric, gas and water utilities around the globe. Our company is the world's leading provider of smart metering, data collection and utility software systems, with over 8,000 utilities worldwide relying on our technology to optimize the delivery and use of energy and water.

To realize your smarter energy and water future, start here: www.itron.com

CORPORATE HEADQUARTERS

2111 N Molter Road
Liberty Lake, WA 99019
USA

Phone: 1.800.635.5461

Fax: 1.509.891.3355

While Itron strives to make the content of its marketing materials as timely and accurate as possible, Itron makes no claims, promises, or guarantees about the accuracy, completeness, or adequacy of, and expressly disclaims liability for errors and omissions in, such materials. No warranty of any kind, implied, expressed, or statutory, including but not limited to the warranties of non-infringement of third party rights, title, merchantability, and fitness for a particular purpose, is given with respect to the content of these marketing materials. © Copyright 2011, Itron. All rights reserved. 101080SP-02 12/11