

SUBMITTAL

Manufacturer: Itron
(formerly Actaris / Schlumberger)
Model: CL34

As Specified	
Capacity Required	
Inlet /Outlet Pres.	
Overpres. Limits	

As Submitted	
Capacity	
Droop	
Build-up	

Options Designations:

-1: For 5"wc to 2 psig outlet
-2: For 1-60 psig outlet

CL34: Internal Registration
CL34-M: Monitor

CL34-IM: Internal Monitor
CL34-IMV: IM with vent hole

Specifications:

	Pilot Spring	Orange Main Spring
1	Green/White	4 – 6" w.c.
1	Blue/White	7 – 13" w.c.
1	Dark Green	13 - 17" w.c.
1	Silver/White	0.5 – 1.25 psig
1	Yellow/White	1.4 – 2.1 psig
2	Brown	0.75-2.5 psig
2	Purple	4-5.5 psig
2	Green	1.5-10 psig
2	Black	5-14 psig
2	Blue	9-30 psig
2	Silver	25-60 psig

Orifice	MAOP
	PSIG delivery
1/4"	175
3/8"	150
3/8" IM	150
1/2"	150
1/2" IM	150
5/8"	150
5/8" IM	150
3/4"	150
7/8"	150

Connections (NPT)	
Inlet	Outlet
1-1/4"	1-1/4"
1-1/4"	1-1/2"
1-1/4"	2"
1-1/2"	1-1/2"
1-1/2"	2"
2"	2"
3"	3"

Assembly:

Valve Body	High Tensile Strength Cast Iron
Orifice:	Brass (Aluminum available)
Valve Seat:	Buna-N or silicone
Valve Stem:	Plated Steel
Lever:	Zinc & dichromate plated steel
Upper Diaphr Plate	Zinc & dichromate plated steel
Lower Diaph. Plate	Die cast aluminum
Diaphragm	Buna N & nylon reinforcing mtl.
Vent Screen	Stainless Steel

Dimensions:

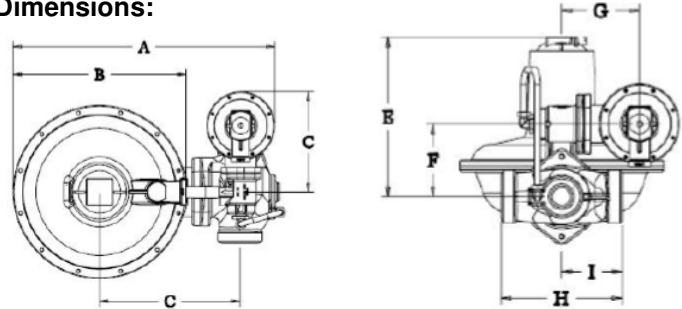

	A	B	C	D	E	F	G	H	I
NPT	19-5/16	12-3/4	7-5/16	8-11/16	10	4-5/16	4-7/8	5-3/4	2-7/8
Flanged	20-1/2	12-3/4	7-5/16	8-11/16"	10	4-5/16	4-7/8	10	5

General Note on installation: The regulator includes a pilot regulator to control outlet pressure. The pilot regulator feeds necessary pressure on top of the diaphragm. The pilot regulator has a small vent with a stainless steel vent screen. On outside installations, the pilot regulator should be oriented with the vent pointing down to keep water or ice from entering the vent. If the pilot regulator is installed with the vent pointing up or to the side, the vent screen should be removed and an elbow (or elbows) should be installed to position the vent correctly. If installed inside, the pilot vent must be piped to a safe outside location in accordance with NFPA 54 recommendations and/or local codes.

Typical Capacity:

Note: Capacity will change as a function of the orifice size, inlet pressure & outlet pressure setting. The capacity tables below are for a typical configuration: 2" CL34 Regulator, with 3/4" orifice. IM models and smaller orifices may have less capacity. Outlet pipe size and length may also reduce flow. Consult complete brochure for capacities and relief curves of other configurations.

Capacity as a Function of Set Point in MSCFH					
Inlet	7" w.c.	1 PSIG	2 PSIG	5 PSIG	10 PSIG
2 PSIG	4.5	3.5			
5 PSIG	7.5	7.0	6.3		
10 PSIG	10.9	10.5	10.1	8.9	
20 PSIG	15.4	15.4	15.4	15.4	14.0



Capacities expressed for 0.6 s.g. nat. gas
S- Denotes standard stock configuration