

MT-185-E

Distributed By



Meter, Valve & Control
877-566-3837

ENGLISH

PRESSURE REGULATOR



TECHNICAL MANUAL

INSTALLATION , COMMISSIONING
AND MAINTENANCE ISTRUCTIONS



Dival 600

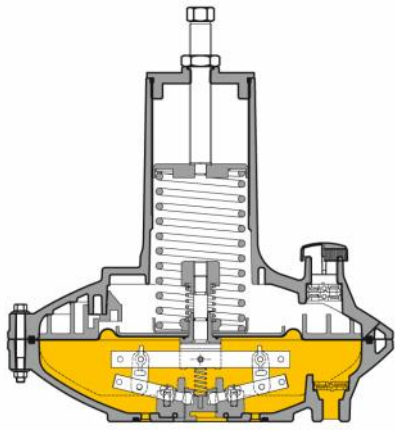

TR. Head

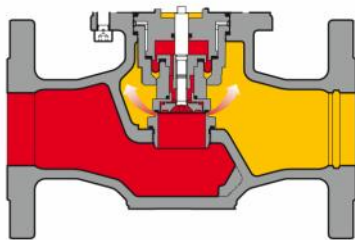

3 Way body

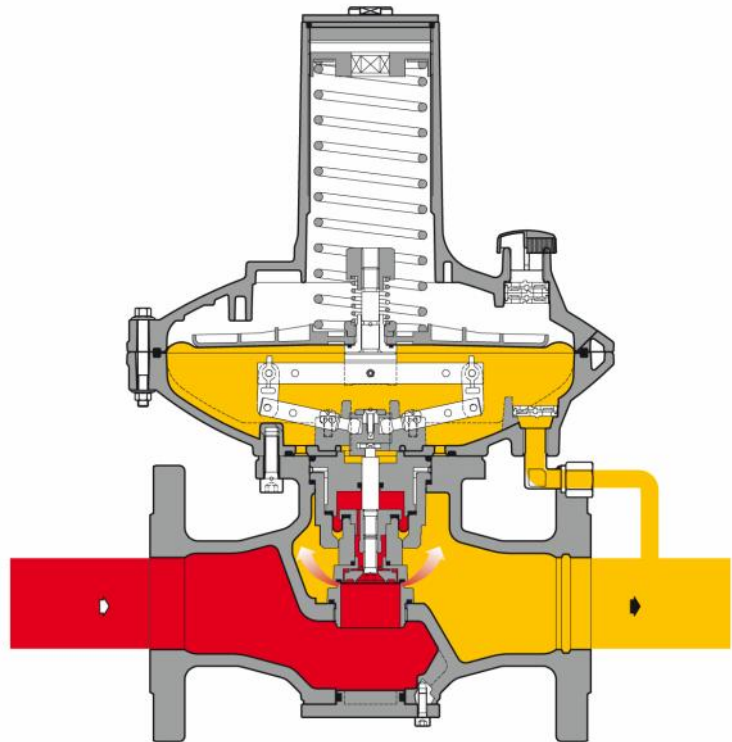

4 Way body.



INLET PRESSURE



OUTLET PRESSURE

PRECAUTION

GENERAL PRECAUTION

The apparatus described in this manual is a device subject to pressure installed in systems under pressure;
The apparatus in question is normally installed in systems for transporting flammable gases (natural gas, for example).

PRECAUTION FOR THE OPERATORS

- Before proceeding with installation, commissioning or maintenance, operators must:
- Examine the **safety provisions** applicable to the installation in which they must work;
- Obtain the **authorisations** necessary for working when required;
- Use the necessary means of **individual protection** (helmet, goggles, etc.);
- Ensure that the area in which they operate is fitted with the means of **collective protection** envisaged and with the necessary **safety indications**.

HANDLING

The handling of the apparatus and of its components must only be carried out after ensuring that the lifting gear is adequate for the **loads to lift** (lifting capacity and functionality). The apparatus must be handled using the **lifting points** provided on the apparatus itself. Motorised means must only be used by the persons in charge of them.

PACKING

The packing for transportation of equipment and of relevant spare parts are designed and shaped to avoid damage to any part during transportation, warehousing and handling activities. Therefore the equipment and spare parts shall be kept into their packing until their installation in the final site. After packing is open, check that no damage occurred to any goods. If damage occurred inform the supplier and keep packing for any verification.

INSTALLATION

The installation of the pressure regulator has to occur in compliance with the provisions (laws or standards) in force in the place of installation.

In detail, natural gas plants have to show features in compliance with the law provisions and standard requirements in force in the place of installation or at least in compliance with standards EN 12186 or EN 12279; in detail, it is necessary to meet the provisions of paragraphs 6.2, 7.5.2, 7.7, 9.3 of the standard EN 12186 and 6.2, 7.4, 7.6, 9.3 of the EN 12279 standard. The installation in compliance with such standards minimizes the risk of fire hazard and the formation of potentially explosive atmospheres.

The valve is not equipped with external pressure limitation devices; therefore, it has to be installed making sure that the operating pressure of the assembly on which it is installed does not exceed the maximum allowable pressure (PS).

Therefore, the user, as deemed necessary by the same, shall install on the assembly suitable pressure limitation systems, as well as provide the plant with suitable relief or drain systems in order to discharge the

pressure and fluid contained in the plant before proceeding with any inspection and maintenance activity.

If the installation of the apparatus requires the application of **compression fittings** in the field, these must be installed following the **instructions of the manufacturer** of the fittings themselves. The choice of the fitting must be compatible with the use specified for the apparatus and with the specifications of the system when envisaged.

COMMISSIONING

Commissioning must be carried out by **adequately trained personnel**. During the commissioning activities, the personnel not strictly necessary must be ordered away and the no-go area must be properly signalled (signs, barriers, etc.).

Check that the settings of the apparatus are those requested; if necessary, reset them to the required values in accordance with the procedures indicated in the manual.

When commissioning, the risks associated with any discharges into the atmosphere of flammable or noxious gases must be assessed.

In installations in natural gas distribution networks, the risk of the formation of explosive mixtures (gas/air) inside the piping must be considered.

CONFORMITY TO DIRECTIVE 97/23/EC (PED)

Pressure regulator **Dival 600** is classified as **pressure accessory** according to directive 97/23/EC (PED).

The pressure regulator **Dival 600** with embedded block device, with pressure switch for tripping in case of maximum pressure, is defined as a safety accessory according to PED Directive and, therefore, it can be used both as a pressure accessory and a safety accessory, always according to the PED Directive.

The configuration of the regulating pressure regulator plus in line monitor regulator is defined as safety accessory according to the PED Directive.

In this case the user shall verify that the maximum allowable pressure (PS) of pressure equipment to be protected is consistent with setting and closing class (**SG**) of monitor regulator; the pressure inside pressure equipment shall be lower than 110% of **PS**.

Conformity with Directive 97/23/EC and CE marking of pressure regulator and relevant accessory require installation in the system with minimum requirements according to EN12186).

- INDEX -.

1.0 INTRODUCTION 4

- 1.1 MAIN FEATURES 4
- 1.2 OPERATION OF THE PRESSURE REGULATOR DIVAL 600 4
- 1.3 SETTING SPRINGS 5

2.0 INSTALLATION 6

- 2.1 GENERAL 6
- 2.2 CONNECTING THE APPARATUSES 7
- 2.3 DOWNSTREAM VOLUME REQUIRED FOR INSTALLATION 8

3.0 MODULARITY' 8

- 3.1 LA.. INCORPORATED SLAMSHUT 8
- 3.2 LA.. SLAMSHUT SETTING SPRINGS 10
- 3.3 DIVAL 600 FUNCTIONING AS A MONITOR 11
- 3.3.1 CONSTRUCTIVE CHARACTERISTICS 11
- 3.4 INTEGRATED SILENCER 11

4.0 ACCESSORIES 12

- 4.1 RELIEF VALVE 12
- 4.1.1 DIRECT INSTALLATION IN THE LINE 12
- 4.1.2 INSTALLATION 12

5.0 START UP 13

- 5.1 GENERAL 12
- 5.2 GAS INPUT, CONTROL OF EXTERNAL TIGHTNESS AND SETTING 13
- 5.3 COMMISSIONING THE REGULATOR 13
- 5.4 COMMISSIONING THE REGULATOR WITH INCORPORATED LA.. SLAMSHUT 13
- 5.5 COMMISSIONING THE REGULATOR PLUS DIVAL 600 IN LINE MONITOR WITH INCORPORATED LA.. SLAMSHUT VALVE/ 15

6.0 TROUBLE-SHOOTING 16

- 6.1 TABLE 8 REGULATOR 16
- 6.2 TABLE 9 SLAMSHUT 17

7.0 MAINTENANCE 18

- 7.1 GENERAL 18
- 7.2 DIVAL 600 REGULATOR MAINTENANCE PROCEDURE 18
- 7.3 DIVAL 600 REGULATOR 18
- 7.4 REPLACEMENT THE ANTI-PUMPING VALVE 21
- 7.5 LA.. SLAMSHUT VALVE 25

8.0 FINAL OPERATION 26

- 8.1 CHECKING THE TIGHTNESS AND SETTING 26
- 8.2 START UP 26

1.0 INTRODUCTION

The scope of this manual is to provide the essential information for the installation, commissioning, disassembly, re-assembly and maintenance of **DIVAL 600** regulators. It is also appropriate to provide a brief illustration of the main features of the regulator and of its accessories.

1.1 MAIN FEATURES

The **DIVAL 600** pressure regulator is a pressure regulator for previously cleaned gaseous fluids and is suitable for medium and low pressures.

The **DIVAL 600** is a normally open regulator and consequently opens in the event of:

- Breakage of the main diaphragm;
- No regulated pressure signal.

The main specifications of this regulator are:

- Design pressure **PS**: up to 20 bar;
- Operating Temperature range: -20 °C to + 60 °C;
- Ambient Temperature range: -20 °C to + 60 °C;
- Inlet pressure range **bpu**: 0,2 to 20 bar;
- Possible regulation range **Wd**:
10 to 350 mbar for head Ø 280;
280 ÷ 4400 mbar for head Ø 280/TR;
- Minimum differential pressure: 0.1 bar;
- Accuracy class **AC**: up to 5 (according to the output pressure field);
- Lockup pressure class **SG**: up to 10 (according to the output pressure field)

1.2 OPERATION OF THE PRESSURE REGULATOR DIVAL 600 (fig. 1)

In absence of pressure the obturator 3 is kept in open position from the hook of shaft 9 on the side of the levers 13 (fig. 1).

The outlet pressure P_d is checked through the comparison between the load of the spring 43 and the impulse of the outlet pressure on the membrane 19.

In this comparison are involved also the weight of the mobile equipment and the dynamic thrusts on the obturator.

The upstream pressure, although it is variable, has not any influence on the balance of the obturator 3, since this latter, due to the presence of the hole A, is positioned between two equal pressures acting on equal surfaces.

The movement of the diaphragm 9 is transmitted by the lever system 13 to the stem 9 and hence to the obturator 3. The obturator 3 is fitted with a vulcanized rubber gasket to ensure perfect tightness with zero flow rate demand.

If, during operation, the downstream pressure drops, the force it exerts on the diaphragm 19 becomes lower than the load of the spring 43. The diaphragm therefore drops and, by means of the lever system 13, pulls the obturator 3 away from the valve seat 2. The gas flow, therefore, increases until the initial pressure set-point is restored.

If, on the other hand, the downstream pressure begins to increase, the force exerted on the diaphragm 19 exceeds the load the spring 43. The obturator is therefore displaced towards the closed position, returning the downstream pressure the set-point.

In normal working conditions, the obturator 3 is positioned in such a way as to maintain the pressure P_d around the selected set-point.

To adjust the pressure set-point you can turn the internal adjustment ring 28 appropriately, clockwise to increase and anticlockwise to reduce it. Normally the plug is only used to cover the lower band of the various setting ranges; the adjusting screw is used for the higher values.

The pressure regulator is equipped with two anti-pumping devices 33 and 34 (fig. 1), which are in charge of slowing down the inflow/outflow of the gas/air in the head only during the transitory phases, in order to avoid possible oscillation phenomena of the regulated pressure.

There are also two stops V1 and V2 for the purpose of eliminating damaging effects which could derive from accidental over-pressures below the diaphragm 19 or from overloading of the spring 43.

Usually, a solution of the type shown in fig. 2a is adopted in order to protect the obturator against damages resulting from sudden increases of the regulated pressure.

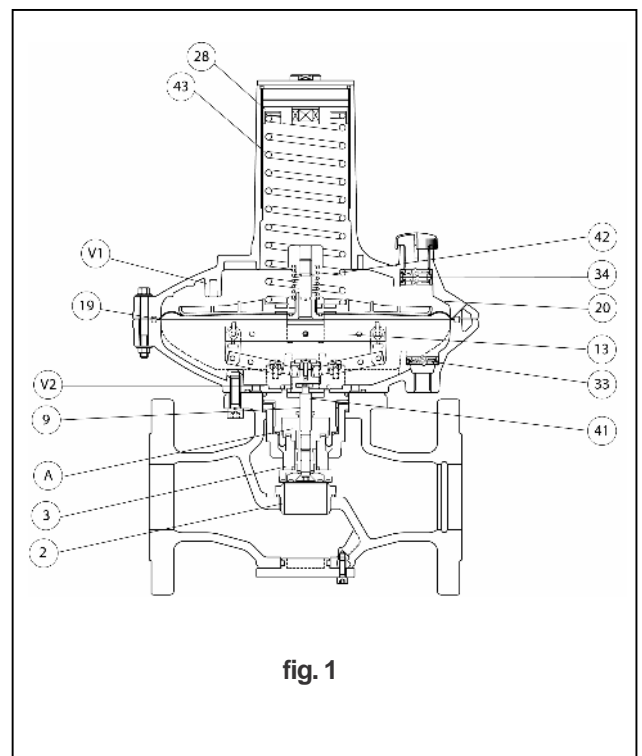

In fact, this solution allows the diaphragm protection disc 20 to rest on the upper stroke end V1 exceeding the load of the spring 42 and thus releasing the obturator from the load resulting from the sudden pressure increase.

In order to prevent small leaks at null required flow rate or that sudden and temporary overpressures, resulting for example from fast manoeuvres or gas overheating, may let the slam-shut valve trip, the solution shown by fig. 2a can be transformed, upon request, into an embedded relief valve, eliminating the O-ring 73 and adding the ring 70 (fig. 2b).

Its operation is described as follows: with closed regulator, any overpressures lift the diaphragm protection disc 20 exceeding the load of the springs 42 and 43. In this way, a given quantity of gas is discharged through the seat Z of the relief valve.

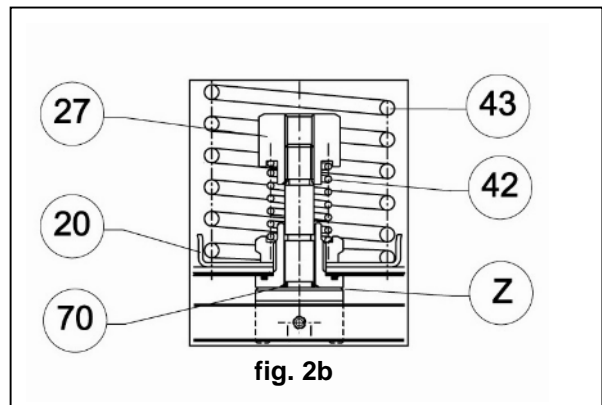
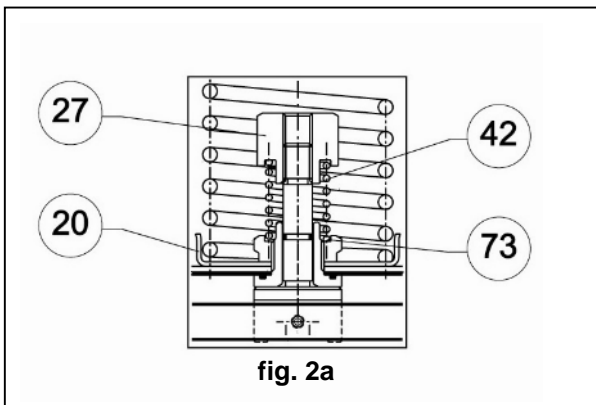

1.3 Tab. 1 SETTING SPRING

Table 1 shows the calibration fields of the different foreseen springs.

Springs Characteristics					Dival 600	
Code	Colour	De	Lo	d	Setting range (mbar)	HEAD
2701345	YELLOW	65	180	3.5	10 ÷ 18	280
2700525 *	ORANGE	22	2	40		
2701620	ORANGE	65	180	4	15 ÷ 30	
2700525 *	ORANGE	22	40	22		
2701860	RED	65	180	4.5	25 ÷ 49	
2700525 *	ORANGE	22	40	2		
2702190	GREEN	65	180	5	40 ÷ 75	
2700645 *	RED	22	40	2,3		
2702370	BLACK	65	180	5.5	62 ÷ 120	
2700645 *	RED	22	40	2,3		
2702540	BLU	65	180	6	100 ÷ 170	
2700645 *	RED	22	40	2,3		
2702730	LIGHT BLUE	65	180	6,5	145 ÷ 270	
2700645 *	RED	22	40	2,3		
2702950	BROWM	65	180	7	230 ÷ 350	
2700645 *	RED	22	40	2,3		
2701345	YELLOW	65	180	3.5	8 ÷ 15	280 REGULATOR UPSIDE DOWN
2700525 *	ORANGE	22	40	2		
2701620	ORANGE	65	180	4	12 ÷ 26	
2700525 *	ORANGE	22	40	2		
2701860	RED	65	180	4.5	21 ÷ 46	
2700525 *	ORANGE	22	40	2		
2702190	GREEN	65	180	5	36 ÷ 70	
2700645 *	RED	22	40	2,3		
2702370	BLACK	65	180	5.5	57 ÷ 120	
2700645 *	RED	22	40	2,3		
2702540	BLU	65	180	6	100 ÷ 170	
2700645 *	RED	22	40	2,3		
2702730	AZZURRO	65	180	6,5	145 ÷ 270	
2700645 *	RED	22	40	2,3		
2702950	BROWN	65	180	7	230 ÷ 350	
2700645 *	ROSSO	22	40	2,3		
2702940	LIGHT BLUE	65	150	7	280 ÷ 720	280/TR
2703125	WHITE-YELLOW		150	7.5	590 ÷ 1000	
2703325	WHITE-ORANGE		150	8	840 ÷ 1250	
2703685	WHITE-GREEN		150	9	1050 ÷ 2300	
2703995	WHITE-BLACK		150	10	2000 ÷ 4400	

De = external diameter d = wire diameter Lo = length * = for internal relief valve.

2.0 INSTALLATION

2.1 GENERAL

Pressure regulator does not require any supplementary upstream safety accessory for protection against overpressure compared with its design pressure **PS**, when upstream reducing station is sized for a max downstream incidental pressure **M Pd 1,1 PS**.

Before installing the regulator it is necessary to ensure that:

- The regulator can be inserted in the space provided and that subsequent maintenance operations will be sufficiently practicable (see overall dimensions in table 2);
- Inlet and outlet pipings must be at the same level and able to carry the weight of the regulator (see chart 2b);
- The inlet/outlet flanges of the piping are parallel;
- The inlet/outlet flanges of the regulator are clean and the regulator itself has not been subject to damage during transport;
- The piping upstream has been cleaned to expel residual impurities such as welding scale, sand, paint residues, water, etc.

The usually foreseen arrangement is the one indicated in figure 3.

Other possible installations are shown in figure 4

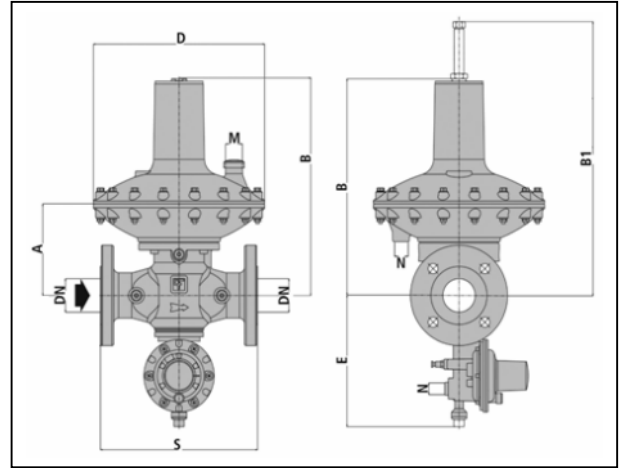

Tab. 2a: Overall dimensions in mm

Tipo	DN	NPS	S	A	B	B1	E	D	M	N
Dival 600	25	1"	183	145	343	433	215	280	Rp 1/2"	Rp 1/4"
Dival 600	40	1"1/2	223	145	343	433	215	280	Rp 1/2"	Rp 1/4"
Dival 600	50	2"	254	158	343	433	215	280	Rp 1/2"	Rp 1/4"
Dival 600	G2"	2 NPT	152,4	158	343	433	215	280	Rp 1/2"	Rp 1/4"

Tab. 2b: Weights in KGF

Type	DN	NPS	Dival	Dival with slam shut valve LA/...
Dival 600	25	1"	15	16
Dival 600	40	1"1/2	17	18
Dival 600	50	2"	20	21
Dival 600	G2"	2 NPT	18	19

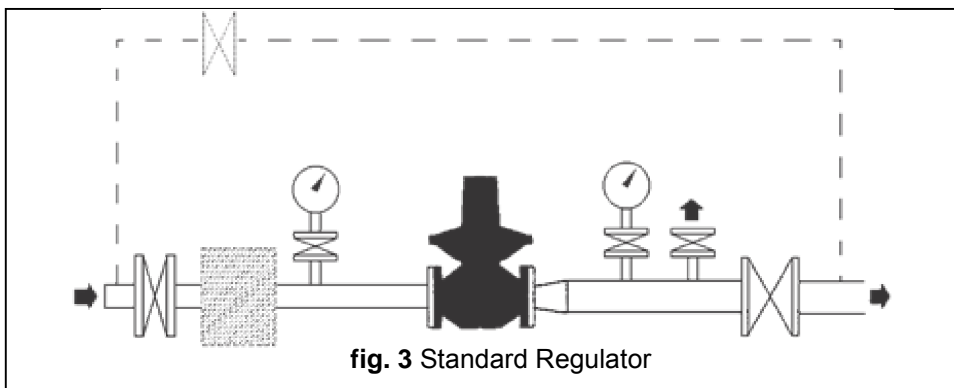

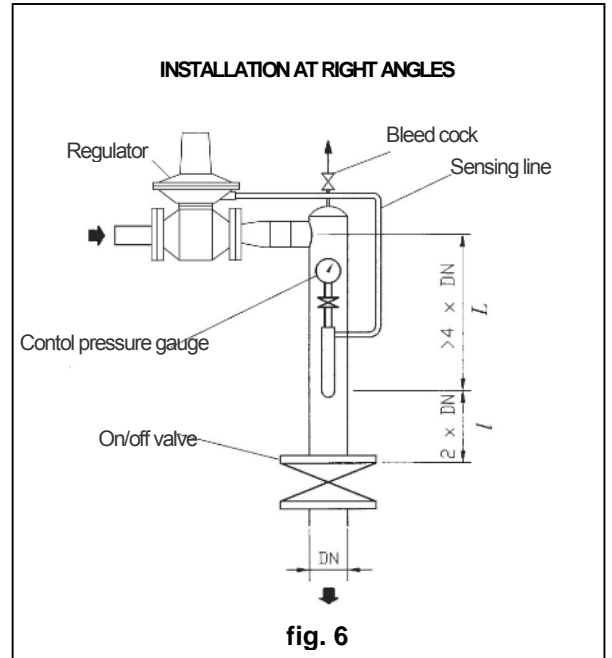
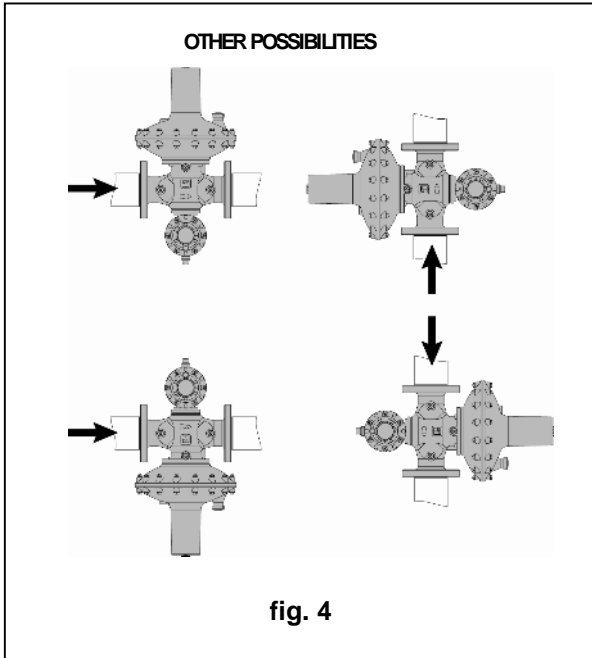

2.2 CONNECTING THE DEVICES

The connections between the apparatus and the main piping must be made using stainless steel or cooper pipe with minimum internal diameter of 8 mm.

Tab.3: Detail of multiple take-off

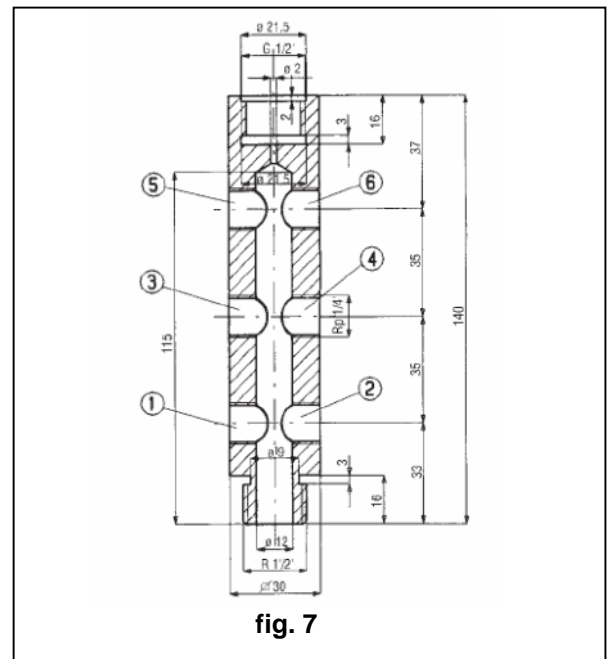
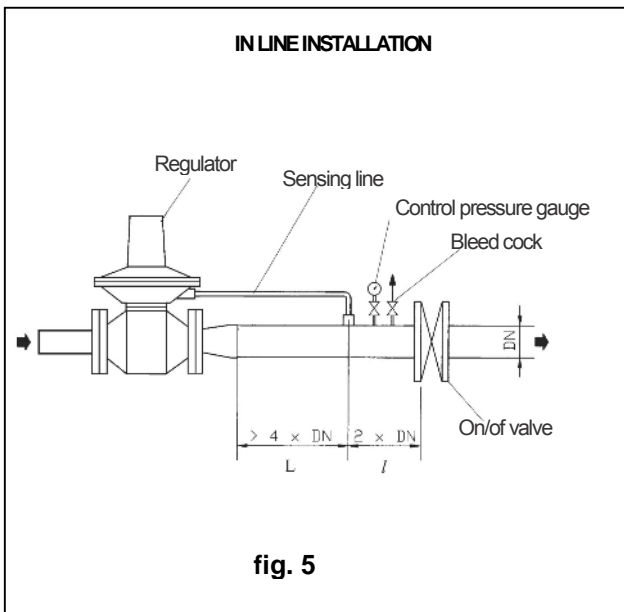

The installation of a multiple plug on a plant has its aim in in taking from a single point all the pressure impulse signals that go to the different reduction- safety devices and to their accessories.

The regulator must be installed in the line **with the arrow on the body pointing in the gas flow direction.**

It is indispensable for good regulation for the position of the downstream pressure take-offs and the speed of the gas at the take-off point respect the value given in table 4.

The regulator, when used in gas pressure reduction stations, has to be installed at least according to the requirements set forth by the standards EN 12186 or EN 12279. All points for possible gas relief due to possible breaks of sensors/diaphragms are to be conveyed according to standards EN 12186 or EN 12279.

The following is recommended so as to prevent the accumulation of impurities and condensate in the lines of the pressure take-off.

- a) The lines themselves must slope down towards the downstream piping with a slope of about 5-10‰;
- b) The connectors on the piping must always be welded on the top of the piping itself and there must be no burr or inward protrusions in the hole in the piping.

N.B. WE RECOMMEND NOT TO PUT ON/OFF VALVES ON THE IMPULSE TAKE-OFFS

Tab.4
The speed of the gas must not exceed the following values in the piping down-stream from the regulator:
Vmax = 25 m/s for 1,5 < Pd < 4 bar
Vmax = 20 m/s for 0,5 < Pd < 1,5 bar
Vmax = 15 m/s for Pd < 0,5 bar

2.3 DOWNSTREAM VOLUME REQUIRED FOR INSTALLATION

In the case of a service regulator of the ON-OFF type (stopping or starting of burners), you should remember that though the **DIVAL 600** apparatus is classified as being of the fast reaction type, it requires an appropriately dimensioned volume of gas between the apparatus itself and the burner so as to partly absorb the pressure swings caused by fast flow rate variations.

3.0 MODULARITY

The modular-type conception of **DIVAL 600** regulators means that it is also possible to fit the slam-shut incorporated with the body itself even after the installation of the regulator (**only for 4-ways-body version**).

3.1 LA/.. INCORPORATED SLAM SHUT

This is a device (fig. 8 and 9) which immediately blocks the gas flow if, because of some failure, the downstream pressure reaches the point set for its intervention, or if it is actuated manually.
 Wat the **DIVAL 600** pressure regulator, the slam-shut be incorporated on both the service regulator or on the in-line monitor. Three versions (LABP, LAMP and LA/TR) are available depending on the intervention pressure ranges

The main features of the slam-shut device are as follows:

- Design pressure **PS**: up to 20 bar;
- Intervention for pressure increase and/or decrease;
- Intervention accuracy **AG**: ± 5% of the set point for pressure increase (based on setting-pressure);
 ± 15% of the set point for pressure drop (based on setting-pressure);
- internal by-pass device;
- manual button-operated actuating device.

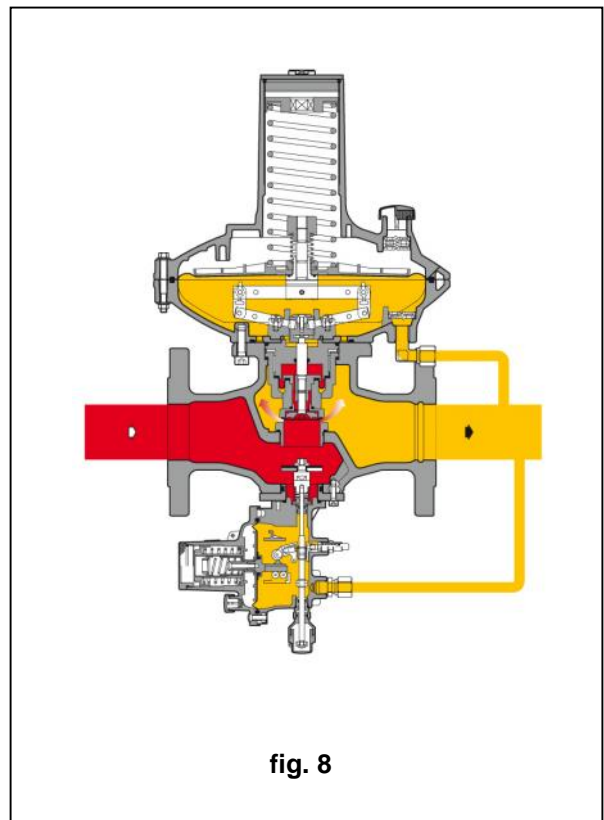

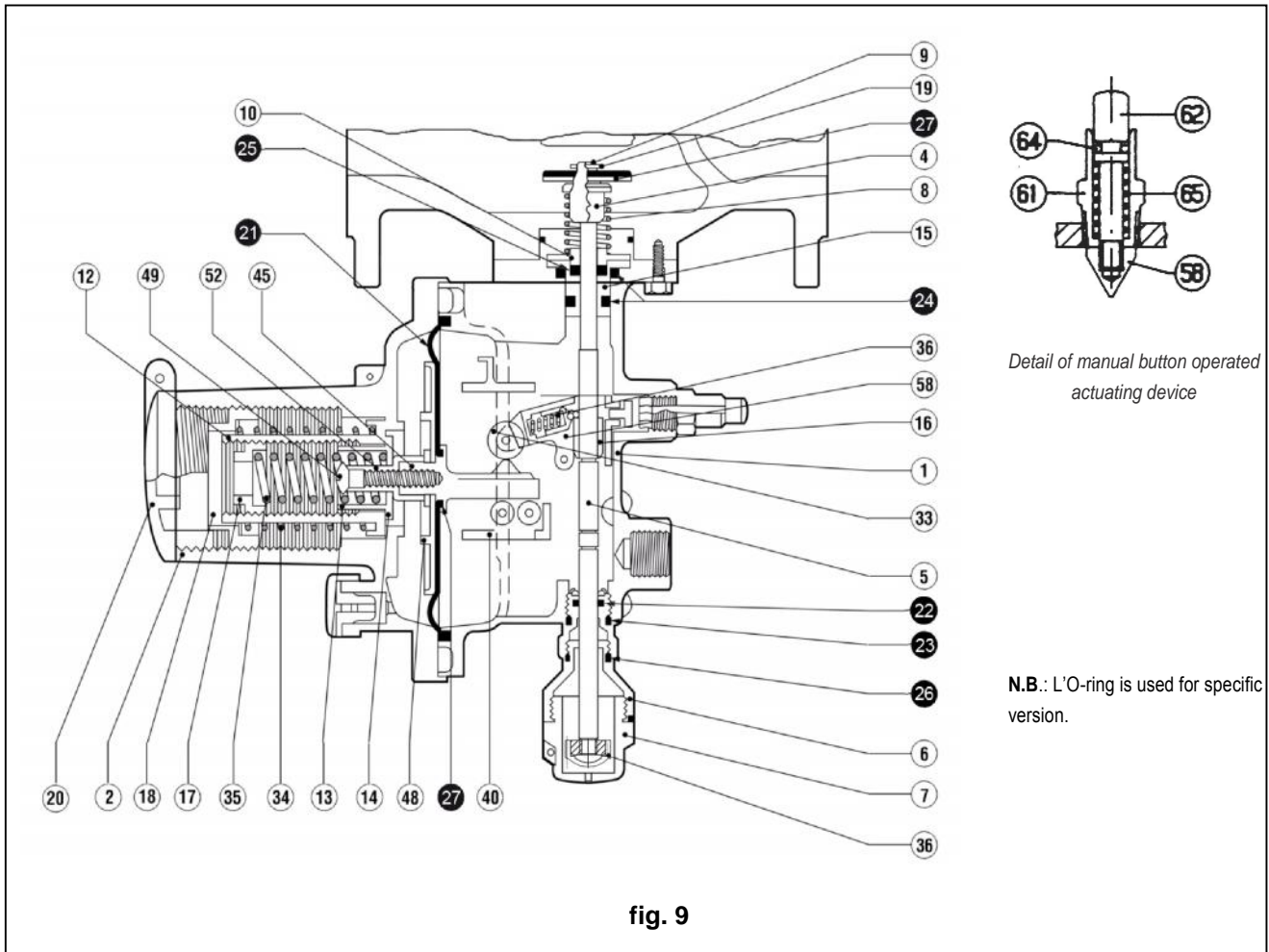

The slam-shut valve **LAV.** consists essentially of an obturator (fig. 9) fitted on a stem, a releasing lever system, a control head and a manual resetting system. The pressure to control Pd in chamber C of the control head, acts on the diaphragm 46 which is integral with the cam shaft 45.

The load of the pressure Pd on the diaphragm is countered by the springs 34 and 35 which respectively determine intervention for pressure increase and pressure decrease. The device is set by turning the rings 17 and 18. Turning the rings clockwise increases the intervention value; turning anticlockwise decreases it.

Intervention as a result of a pressure increase occurs as follows: when the pressure Pd exceeds the set point the load on the diaphragm 4 increases until it overcomes the resistance of the spring 34. This causes the shaft 45 to translate towards the left so that the cam shifts the feeler 33 and trips the lever mechanism 29. In this way, the stem 5 with the obturator 19 is freed and closed by the spring 8.

On the other hand, intervention as a result of a pressure decrease occurs as follows: as long as the pressure Pd stays above the load of the spring 35, the spring support 13 rest on the support 12. If the pressure Pd drops below the set point, the spring 35 translates the support 13 to the right and with it the shaft 45.

The cam shifts the feeler 33 and trips the lever mechanism 29. The slam-shut is reset by unscrewing the bushing 7 and pulling it downwards until the lever system 29 is reset.

During the first phase of the operation, it will be necessary to wait until the upstream pressure, through the internal by-pass, passes downstream from the obturator to rebalance it. After resetting, the bushing 7 must be screwed back to its seat.

It is possible to see from the outside whether the slam-shut is open or closed by observing the position of the nut 37 through in the bushing 7, as shown in figure 9.

Table 5 lists the range of intervention of the pressure switches available.

3.2 Tab. 5 LA... SLAM-SHUT SETTING SPRINGS

Spring characteristics					SLAM-SHUT LA/BP
Code	Colour	De	Lo	d	SETTING RANGE in mbar
					Intervention for max. pressure
64470112 RO	RED	34	43	2.2	30 ÷ 50
64470115GR	GREY		42	2.8	50 ÷ 180
					Intervention for min. pressure
64470024BI	WHITE	15	45	1.3	6 ÷ 60
					SLAM-SHUT LA /MP
					Intervention for max. pressure
64470115GR	GREY	34	42	2.8	140 ÷ 180
64470116GI	YELLOW		40	3.2	180 ÷ 280
64470051BI	WHITE		50	3.2	280 ÷ 450
					Intervention for min. pressure
64470024BI	WHITE	15	45	1.3	10 ÷ 60
6470038GI	YELLOW		40	2	60 ÷ 240
					SLAM-SHUT LA /TR
					Intervention for max. pressure
64470116GI	GREY	34	40	3.2	250 ÷ 550
64470051BI	WHITE		50	3.2	550 ÷ 850
64470057BL	BLUE		50	3.5	850 ÷ 1500
64470058AR	ORANGE		50	4	1500 ÷ 2500
64470059AZ	LIGHT BLUE		50	4.5	2500 ÷ 4000
64470060NE	BLACK		50	5	4000 ÷ 5500
					Intervention for min. pressure
64470038GI	YELLOW	15	40	2	100 ÷ 500
64470045MA	BROWN		41	2.4	500 ÷ 1000
64470046BL	BLUE		40	3	1000 ÷ 2000
64470149NE	BLACK		43	3.2	2000 ÷ 3500

De = Ø external diameter d = Ø wire diameter Lo = Length

3.3 DIVAL 600 FUNCTIONING AS A MONITOR

The monitor is an emergency regulator whose function is to come into service instead of the main regulator when failure of the latter causes the downstream pressure to reach the point set for monitor intervention.
 PIETRO FIORENTINI has a solution for this emergency device for in-line installations.

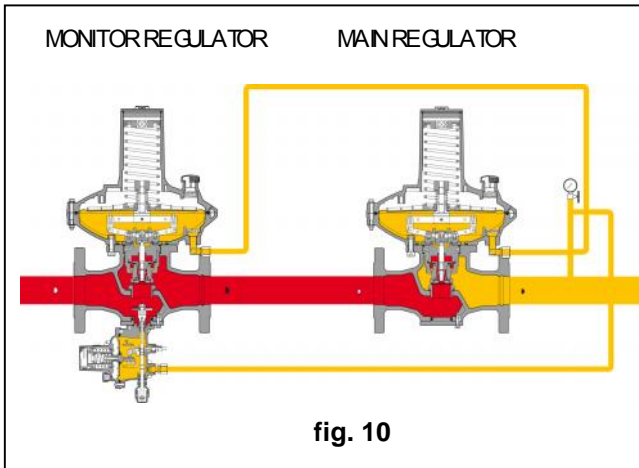

3.3.1 CONSTRUCTIVE CHARACTERISTICS

The **DIVAL 600** with monitor functions is a regulator which, compared with the normal version, has a further mobile assembly balancing device which guarantees greater precision in the regulated pressure and therefore an equally precise pressure intervention value without problems of interference with the main regulator.
 In this configuration, the monitor regulator has a construction variation which is illustrated in fig. 11.

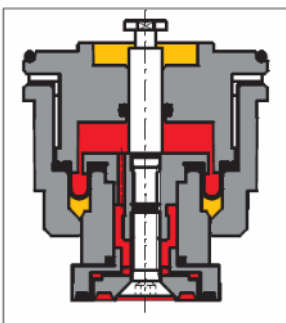

fig. 11a

STANDARD REGULATOR

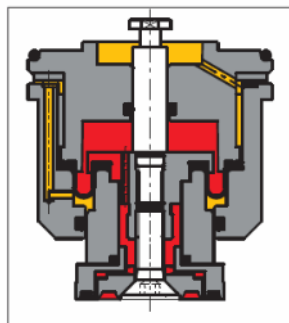

fig. 11b

MONITOR REGULATOR

3.4 INTEGRATED SILENCER

This device allows a strong noise decrease caused by the reduction of gas pressure, when this condition is required by particular environmental conditions.
 Pressure Regulator **Dival 600** can have an integrated silencer both in the normal version and in the version having block valve or on-line monitor.
 Given the modular conception of the regulator, the silencer can be assembled on any kind of of Regulator **Dival 600** already installed, without having to modify incoming and outgoing pipings. The pressure reduction and regulation method is the same as the base-version regulator.

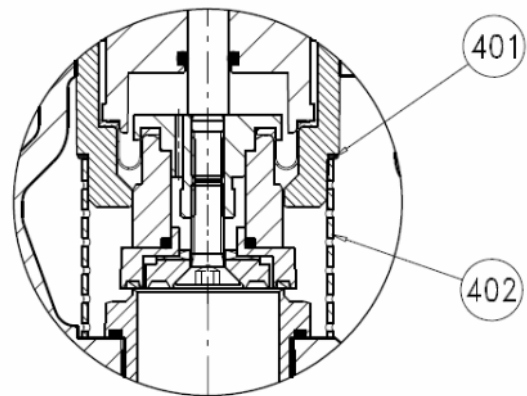

fig.12

4.0 ACCESSORIES

4.1 RELIEF VALVE

The relief valve is a safety device which releases a certain quality of gas to the exterior when the pressure at the control point exceeds the set-point as a result of short-lasting events such as, for example, the very fast closing of the on/off valves and/or overheating of the gas with zero flow rate demand. The release of the gas to the exterior can, for example, delay or block the intervention of the slam-shut valves for transitory reasons deriving from damage to the regulator.

Obviously the quantity of gas released depends on the extent of the overpressure with respect to the set-point.

The different models of relief valves available are all based on the same operating principle which is illustrated below with reference to the valve VSAM65 (fig. 12). It is based on the contrast between the thrust on the diaphragm 24 deriving from the pressure of the gas to control and the thrust from the setting spring 20. The weight of the mobile assembly, the static thrust and the residual dynamic thrust on the obturator 4 also contribute to this contrast. When the thrust deriving from the pressure of the gas exceeds that of the setting spring, the obturator 4 is raised and a certain quality of gas is released as a result. As soon as the pressure drops below the set-point, the obturator returns to the closed position.

Proceed as indicated below to control and adjust intervention of the relief valve.

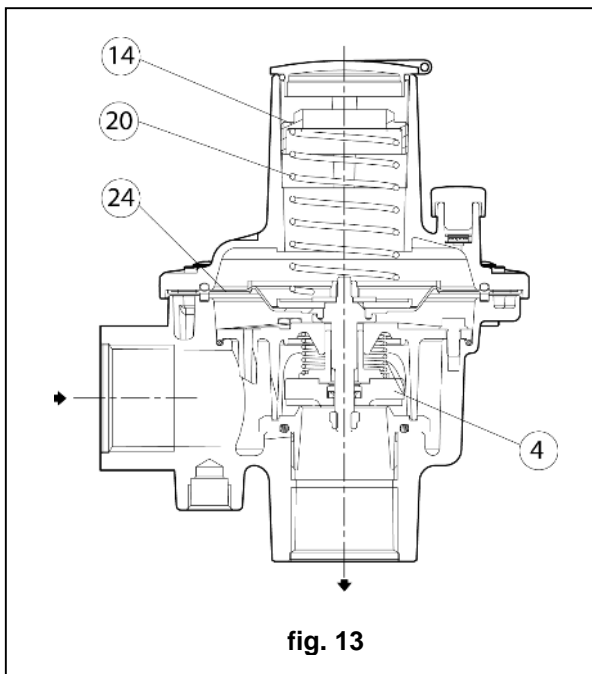

fig. 13

4.1.1 DIRECT INSTALLATION IN THE LINE (fig. 14).

When the relief valves fitted directly in the line that is, without the interposition of an on/off valve, we recommend proceeding as follows:

- 1) Ensure that the downstream on/off valve V2 and the bled cock 6 are closed;
- 2) Connect to the cock 6 a controlled auxiliary pressure and stabilize it to the wished tripping value of the relief valve. Open the bleed cock 6 with a following increase in the pressure of the downstream section;
- 3) Check intervention of the relief valve and adjust it if necessary by turning the internal adjustment ring 14 appropriately (clockwise to increase the set-point, anticlockwise to reduce it).

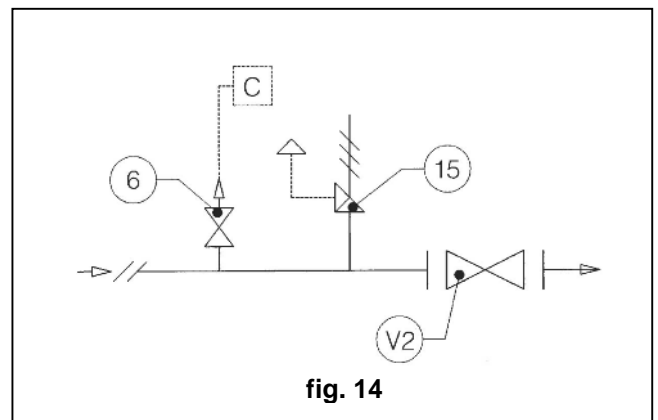

fig. 14

4.1.2 INSTALLATION WITH ON/OFF VALVE (fig. 15)

- 1) Close the on/off valve 16;
- 2) Connect a controlled auxiliary pressure to the take-off valve 17 and increase it slowly to the envisaged intervention value;
- 3) Check intervention of the relief valve and adjust it if necessary by turning the internal adjustment ring 14 appropriately (clockwise to increase the set-point, anticlockwise to reduce it).

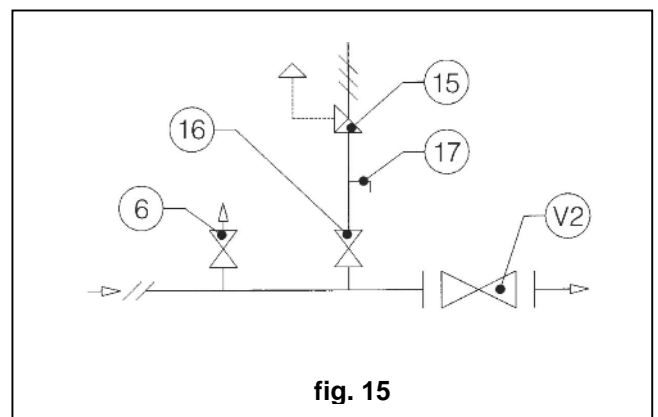

fig. 15

5.0 START UP

5.1 GENERAL

After installation, check that the inlet/outlet on/off valves, any by-pass and the bleed cock are closed.

Before commissioning, you must ensure that the conditions of use comply with the characteristics of the apparatuses.

These characteristics are recalled by the symbols on the specification plates applied to each apparatus (fig. 15).

We recommend actuating the opening and closing valves very slowly.

The regulator could be damaged by operations which are too fast.

It is to be noted that pressure regulators with monitoring functions are identified on the plate by the letters "DIVAL/M".

APPARATUS SPECIFICATION PLATES

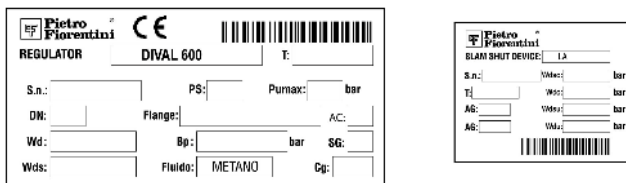

fig. 16

The list of symbols used and their meanings are listed below:

CE = According to 97/23/CE PED Directive

Purnax = maximum operating pressure at the inlet of the apparatus.

bpu = range of variability of the inlet pressure of the pressure regulator in normal operating conditions.

PS = maximum pressure for which the body and its inner metallic partition walls are designed in accordance with the strength requirements in this document.

Wds = setting range of the pressure regulator which can be obtain using the parts and the setting spring fitted at the moment of testing (that is without changing any components of the apparatus).

Wd = setting range of the pressure regulator which can be obtain using the setting springs indicated in the associated tables and also by changing some other part of the apparatus (reinforced gasket, diaphragm, etc.).

Cg and KG = experimental coefficient of critical flow.

AC = regulation class.

SG = closing pressure class.

AG = intervention accuracy.

Wdso = range of intervention for the over pressure of slam-shut which can be obtain using the setting spring fitted at the moment of testing.

Wdo = range of intervention for the over pressure of slam-shut which can be obtain using the setting springs indicated in the tables.

Wdsu = range of intervention for pressure decrease of slam-shut which can be obtain using the setting spring fitted at the moment of testing.

Wdu = range of intervention for pressure decrease of slam-shut which can be obtain using the setting springs indicated in the tables.

5.2 GAS INPUT, CONTROL OF EXTERNAL TIGHTNESS AND SETTING

The pressurization of the equipment shall be performed very slowly. Should not any stabilization procedure be carried out, it is recommended to keep gas speed in the feeding piping at a value equal to 5 m/sec during pressurization.

To protect the apparatus from damage, the following operations must never be carried out:

- Pressurization through a valve located downstream from the apparatus itself.
- Depressurization through a valve located upstream from the apparatus itself.

External tightness is guaranteed if no bubbles form when a foam medium is applied on the element under pressure.

The regulator and any other apparatuses (slam-shut, monitor) are normally supplied already set for the desired set-point. It is possible for various reasons (e.g., vibration during transport) for the settings to be changed while remaining within the values permitted by the springs used.

We therefore recommend checking the settings using the procedures illustrated below.

Tables 6 and 7 give the recommended set-point for the apparatuses in the various installation arrangements. The figures in these tables can be useful both when checking existing set-point and for modifying them should this become necessary later.

In installation consisting of two lines, we suggest commissioning one line at a time, starting from the one with the lower set-point, known as the "reserve" line. The set-point of the apparatuses in the line will obviously deviate from those specified in the tables 6 and 7.

Before commissioning the regulator you must check that all the on/off valves (inlet, outlet, any by-pass) are closed and that the gas is at a temperature which will not lead to malfunction.

5.3 COMMISSIONING THE REGULATOR

If there is also a relief valve in the line, refer to par. 4.1 to check it.

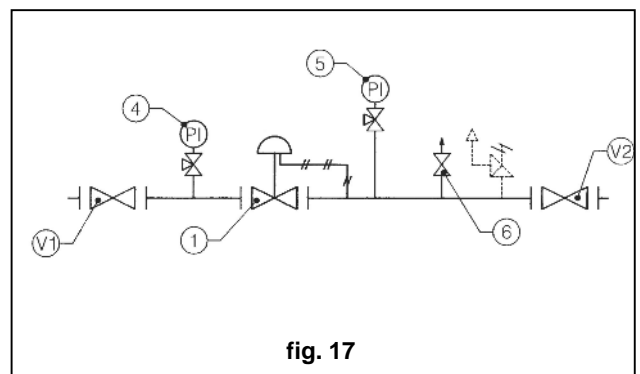

fig. 17

- 1) partially open the downstream bleed cock 6;
- 2) very slowly open the inlet on/off valve V1;
- 3) stabilize pressure upstream and downstream; through the pressure gauge 5 check that the downstream pressure shows the wished calibration value. Otherwise, adjust the calibration acting on the proper internal ring nut (fig. 1), rotating it clockwise to increase and counter-clockwise to decrease;
- 5) close the bleed cock 6 and verify the tightness of the regulator and the value of its closing overpressure;
- 6) check the tightness of all the joints between the on/off valves V1 and V2 using a foam solution;

- 7) very slowly open the downstream on /off valve V2 until the line is completely filled.

5.4 COMMISSIONING THE REGULATOR WITH INCORPORED LA.. SLAM-SHUT

If there is also a relief valve in the line, refer to par. 4.1 to check it.

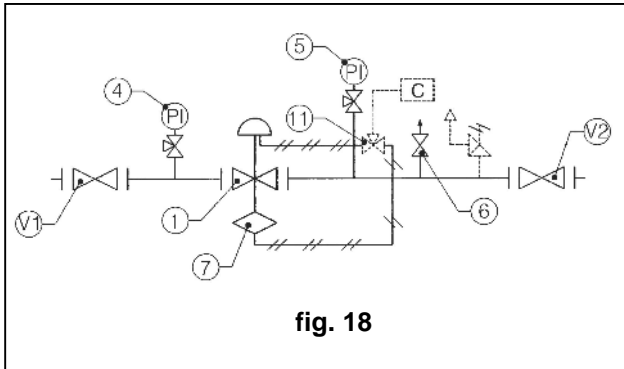

fig. 18

Check and adjust the intervention of the slam-shut 7 as follows:

- A) For slam-shut connected to the downstream piping by a three-ways deviator "push" valve 11, (fig 19) proceed as follows:
 - connect a controlled auxiliary pressure to path C;
 - stabilise this pressure at the set point established for the regulator;
 - press knob 1 of the three-way "push" valve completely;
 - reset the slam-shut device by means of the provided threaded bushing;
 - keep the knob 1 pressed and:
 - for safety devices which intervene for maximum pressure: slowly increase the auxiliary pressure and check the intervention value. If necessary, increase the intervention value by turning the adjustment ring 18 clockwise, or anticlockwise to reduce the intervention value.
 - for safety devices which intervene for pressure increase and reduction: slowly increase the auxiliary pressure and record the intervention value. Restore the pressure to the set point established for the regulator, and carry out slam-shut reset operation.
 - Check intervention for pressure reduction by slowly reducing the auxiliary pressure. If necessary, increase the intervention values for pressure increase or decrease by respectively turning the rings 18 and 17 clockwise and vice-versa to reduce them.
 - **check proper operation by repeating the operations at least 2-3 times.**

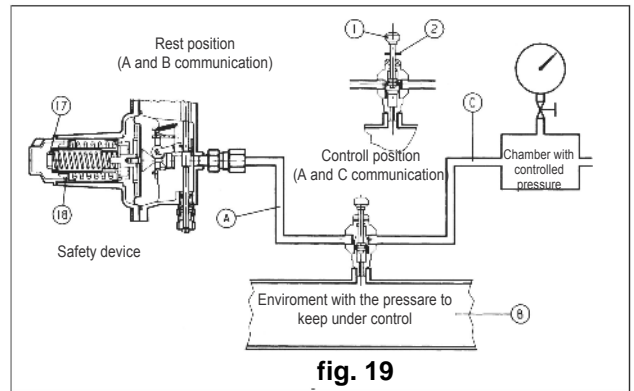

fig. 19

- B) On devices without the "push" valve (fig. 20) we recommend connecting the control head separately to a controlled auxiliary pressure and repeating the operations described above

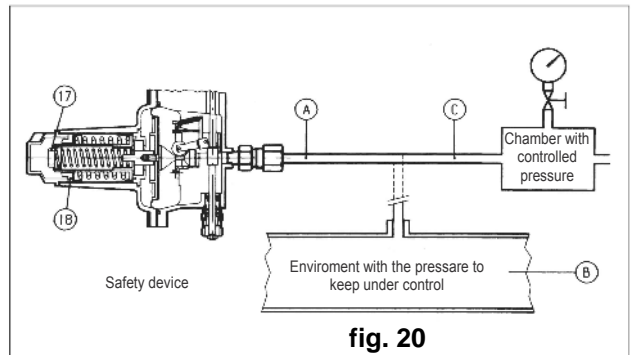

fig. 20

ATTENTION

At the end of the operation, reconnect the control head to the downstream pressure take-off

N.B.: The intervention tests should be repeated at last every months.

At the end of the slam-shut check, proceed as follows:

- 1) Make sure the block is on closing-position;
- 2) Open the inlet block valve V1;
- 3) Open very slowly the block valve, pulling the compass;
- 4) Partially open the relief faucet 6 placed on the outlet piping;
- 5) Check, through pressure gauge 5, that the outlet pressure has the gauging value indicated by the regulator.
If not, it is then necessary to adjust the gauging value, operating on the internal clamp, rotating it clockwise to increase and anti-clockwise to decrease;
- 6) Close the relief faucet 6 and check the value of the closure pressure;
- 7) Using a foaming agent, check the capacity of all the joints placed between block valves V1 and V2
- 8) Open very slowly the outlet block valve V2 until the piping gets completely full;
- 9) It is advisable to check that, activating the block valve manually, the line capacity gets stopped.

Tab. 6 Setting of on-line apparatuses consisting of regulators Dival 600 + Slam-shut + Relief valves			
Regulator set-point (Pds) mbar	Relief Valve	Slam-shut Max	Slam-shut Min
10 < Pds ≤ 15	Pds x 1.7	Pds x 2	Slam-shut not available
15 < Pds ≤ 19			10 mbar
19 < Pds ≤ 24			Pds x 0.56
24 < Pds ≤ 35	Pds x 1.55	Pds x 1.77	Pds x 0.57
35 < Pds ≤ 40		Pds x 1.7	
40 < Pds ≤ 70	Pds x 1.4	Pds x 1.52	Pds x 0.6
70 < Pds ≤ 80			
80 < Pds ≤ 100		Pds x 1.3	
100 < Pds ≤ 750	Pds x 1.46		
750 < Pds ≤ 1000			
1000 < Pds ≤ 2500	Pds x 1.16	Pds x 1.5	Pds x 0.7
2500 < Pds ≤ 4400		Pds x 1.2	

5.5 COMMISSIONING THE REGULATOR PLUS DIVAL 600 IN LINE MONITOR WITH INCORPORATED LA/.. SLAM-SHUT VALVE

If there is also a relief valve in the line, refer to par. 4.1 to check it.

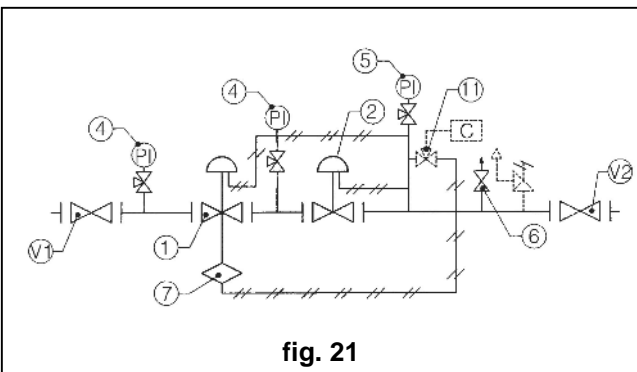

fig. 21

Check and adjust the intervention of the slam-shut 7 as follows:

- A) For slam-shuts connected to the downstream piping by a three-ways deviator "push valve 11, proceed as follows (fig. 19):
- connect a controlled auxiliary pressure to path C;
 - stabilise this pressure at the set point established for the regulator;
 - press knob 1 of the three-way "push" valve completely;
 - reset the slam-shut device by means of the provided threaded bushing;
 - keep the knob 1 pressed and:
 - for safety devices which intervene for maximum pressure: slowly increase the auxiliary pressure and check the intervention value. If necessary, increase the intervention value by turning the adjustment ring 18 clockwise, or anticlockwise to reduce the intervention value.
 - for safety devices which intervene for pressure increase and reduction: slowly increase the auxiliary pressure and record the intervention value. Restore the pressure to the setpoint

established for the regulator, and carry out slam-shut reset operation. Check intervention for pressure reduction by slowly reducing the auxiliary pressure. If necessary, increase the intervention values for pressure increase or decrease by respectively turning the rings 18 and 17 clockwise and vice-versa to reduce them.

- check proper operation by repeating the operations at least 2-3 times.

B) On devices without the "push" valve (fig. 20) we recommend connecting the control head separately to a controlled auxiliary pressure and repeating the operations described above.

ATTENTION

At the end of the operation, reconnect the control head to the downstream pressure take-off

NB.: The intervention tests should be repeated at last every months..

At the end of the slam-shut check, proceed as follows:

- 1) Make sure the block is on closing-position;
- 2) Partially open the relief faucet 6 placed on the outlet piping;
- 3) Unplug the impulse plug of the main regulator 2 and tamp the fitting on the outlet shaft;
- 4) Open very slowly the block valve V1;
- 5) Open very slowly the block valve by pulling the compass;
- 6) Check, through pressure gauge 5, that the outlet pressure has the fixed gauging value for the regulator monitor 1. If not, adjust the gauging value operating on the internal clamp, rotating it clockwise to increase and anti-clockwise to decrease;
- 7) Close the relief faucet and check the closing pressure value of the regulator monitor 1;
- 8) Activate manually the block valve and partially open the relief faucet 6;
- 9) Plug in the impulse plug of the main regulator;
- 10) Open very slowly the block valve, by pulling the compass;
- 11) Check, through pressure gauge 5, that the outlet pressure has the gauging value fixed for the main regulator 2. If not, adjust the gauging value operating on the internal clamp, rotating it clockwise to increase and anti-clockwise to decrease;
- 12) Close the relief faucet and check the outlet pressure value of the main regulator 2;
- 13) Using a foaming agent, check the capacity of all the joints placed between block valves V1 and V2;
- 14) Open very slowly the outlet block valve V2, until the piping gets completely full;
- 15) It is advisable to check, that activating manually the block valve, the line capacity gets stopped.

Tab. 7 Setting of on-line apparatuses consisting of regulator Dival 600 + Monitor + Slam-shut + Relief valve

Regulator set-point (Pds) mbar	MONITOR	RELIEF VALVE	SLAM SHUT Max	SLAM-SHUT Min
10<Pds≤15	Pds + 5 mbar	Pds x 1.7	Pds x 2	Slam-shut not available
15<Pds≤19				10 mbar
19<Pds≤24				Pds x 0.56
24<Pds≤35				Pds x 0.57
35<Pds≤40				Pds x 0.6
40<Pds≤70	Pds x 1.55			
70<Pds≤80	Pds x 1.4			
80<Pds≤100	Pds x 1.3			
100<Pds≤750	Pds x 1.15	Pds x 1.3	Pds x 1.4	Pds x 0.7
750<Pds≤1000	Pds x 1.07		Pds x 1.46	
1000<Pds≤2500			Pds x 1.5	
2500<Pds<4400		Pds x 1.16	Pds x 1.2	

6.0 TROUBLE-SHOOTING

The problems of various kinds which could arise over time are highlighted below. They derive from phenomena associated with the conditions of the gas as well, of course, as with the natural ageing and wear of the materials.

It must be remembered that all operations on the apparatuses must be carried out by highly qualified personnel with appropriate knowledge of the subject. **Tampering with the apparatuses by unsuitable personnel relieves us from all responsibility of any kind.** You must therefore train your maintenance personnel or avail yourself of the service centres officially authorised by us.

6.1 Tab. 8 DIVAL 600 REGULATOR (fig. 22, 23, 24, 25 and 26)

PROBLEM	POSSIBLE CAUSES	REMEDY
No tightness at Q=0	Valve seat [2] damaged	Replace
	Obturator [211] damaged	Replace
	O-ring [202] damaged	Replace
	O-ring [213] damaged	Replace
	O-ring [215] damaged	Replace
	Diaphragm [209] damaged	Replace
	Dirt or foreign bodies in the seal area	Clean
Pumping	Anomalous friction of the rod-obturator	Clean and, if necessary, replace sealing and/or guide elements
	Antipumping valves blockage	Clean and replace if necessary
	Reduced downstream volumes	Increase volume
Increase Pd with Q>0	Diaphragm [321] breakage	Replace
	Diaphragm [209] breakage	Replace

6.2 Tab. 9 SLAM-SHUTH (fig. 27)

PROBLEM	POSSIBLE CAUSES	REMEDY
Slam-shut obturator does not close	Control head diaphragm [16] ruptured	Change the diaphragm
Leakage from slam-shut obturator	Obturator gasket [10] deteriorated	Change the gasket
	O-ring [66] worn	Change
	Obturator seat [7] eroded or pitted	Change the seat
Incorrect intervention pressure	Wrong setting of max and/or minimum spring	Make the setting again using the rings [12] and/or [13]
	Friction in lever systems	Change
Rearming not possible	Persistence of the cause which led to pressure increase or decrease downstream	Decrease or decrease the downstream pressure
	Lever systems broken or chipped	Change

N.B. If the slam-shut has intervened, close the inlet and outlet valve (V1 and V2) in the line and discharge the pressure before carrying out any operation.
Eliminate the causes which gave rise to intervention before reactivating it.

In the event of operating problems when personnel qualified for a specific operation are not available, call the service centre nearest to you.
For further information contact our SATRI service centre at our Arcugnano (Vicenza) works

7.0 MAINTENANCE

7.1 GENERAL

Periodical inspection and maintenance shall be carried out according to the regulations in force (kind and frequencies). Before carrying out any operation it is important to ascertain that the regulator has been cut off both upstream the regulator and the on/off valves. The maintenance operations are closely associated with the quality of the gas transported (impurities, humidity, gasoline, corrosive substances) and with the efficiency of the filtering.

Preventive maintenance should be carried out at intervals which, if not established by regulation in force, depend on:

- The quality of the gas transported;
- The cleanliness and conservation of the piping upstream from the regulator: in general, for example, when starting the equipment for the first time, more frequent maintenance is required because the precarious state of cleanliness inside the piping;
- The level of reliability required from the regulation system.

Before starting the disassembly operations on the apparatus you should check that:

- A set of recommended spares is available. The spares must be original **Florentini** ones, bearing in mind that the more important ones such as diaphragms are marked;
- A set of wrenches is available as specified in table 10.

For a proper maintenance the recommended spare arts are unequivocally identified by labels indicating:

- The No of assembly drawing SR of the apparatus for which the spare parts are suitable;
- The position showed in the assembly drawing SR of the apparatus.
- We advise to replace all rubber-made parts. In order to do this, please use the appropriate replacing kit as highlighted with black spots in the pictures 22, 23, 24, 25, 26 and 27.

N.B. Pietro Fiorentini S.p.A. is in no case responsible, in case of use of non-original replacements.

Before starting disassembling the equipment, it is also necessary to make sure that the plant section on which one is working is not operating upstream or downstream, as well as that the pressure in the involved piping section has been discharged.

The depressurization manoeuvre has to be carried out paying attention to discharge the bleed cocks to the drains in a safe area. To avoid the risk of generating sparks due to bumps of impurity particles within the discharge lines, it is recommended to keep the fluid speed lower than 5 m/sec.

Moreover, it is suggested to perform reference marks, before disassembling the equipment, on the parts that may show problems of mutual orientation or positioning during re-assembly.

Finally, it shall be underlined that the O-rings and the mechanical sliding parts (stems, etc.) must be lubricated, before re-assembling them, with a thin layer of silicone grease. Before commissioning, the external tightness of the equipment has to be tested at a suitable pressure in order to assure the absence of external leaks.

The internal tightness of the block devices and of the monitors, when these are used as safety accessories according to the PED Directive, has to be tested at a suitable pressure in order to assure the internal tightness at maximum foreseen operating pressure. Such tests are essential to assure the safe use under the foreseen operating conditions. They have in any case to comply with the national regulations in force.

7.2 DIVAL 600 REGULATOR MAINTENANCE PROCEDURE

PROGRAMMED PREVENTIVE MAINTENANCE

Procedure for the disassembly, complete replacement of the spare parts and reassembly of the DIVAL 600 pressure regulator + LA/..



PRELIMINARY OPERATION

- A. Render the regulator safe;
- B. Ensure that the pressure upstream and downstream from it is 0.

DISASSEMBLING AND RE-ASSEMBLY

7.3 DIVAL 600 REGULATOR (fig. 22-23-24-25-26)

- 1) Unplug the fitting between the regulators and the outlet pressure plug (impulse plug);



- 2) Completely unscrew the tap (354) and the internal regulating clamp (352). Then take out the spring (341);



- 3) Remove the screws (47) that fix the low support cap (310) with the high support cap(340);



- 4) Remove the high cap(340);



- 5) Completely unscrew the screw-nut (332) and take the spring out (331);



- 6) Take the membrane-group out (320)



- 7) Unscrew the screw-nut (324) to dismantle the protection disc (322), the membrane (321) and the membrane-support (323);
 8) Check, by increasing and decreasing, the correct functioning of the internal levers (301);



- 9) Take the screws out(46);



- 10) Separate the head (300) and the balancing group (200) from the regulator's body (1);



- 11) Separate the balancing group (200) from the head (300) by modifying the flowing-direction of the gas in order to get the shaft (203) getting out of the loading joint (312);



- 12) Unscrew the screw (212) from the obturator (211) and separate all the components of the balancing group (200);



- 13) Unscrew the valve seat from the body (2), paying attention not to damage the sustain rims;



- 14) Unscrew then the screws (48) to dismantle the lower blind flange (10).

To re-install the regulator you can carry out the operations described for the dismantling, in the opposite way.
 Before re-installing the sustain elements (o-rings, membranes, etc...), it is necessary to check their integrity and if that is the case to replace them. It is necessary to make sure that the membrane (209) is perfectly inserted in its seat and that the movement of the shaft-obturator group shows no obstruction.
 You have to be very careful in manipulating the valve seat (2), not to damage the sustain rims.

The internal regulation clamp (352) must be only partially activated.

The maintenance just of the regulation valve (balancing group 300 and valve seat 2) can be carried out without having to intervene on the control head.
In this case, the operations to be followed start from position 9 after having implemented the position 1 operation.

N.B. The anti-pumping small valves (318) do not need usually to be further dismantled, with the exception of functioning problems;

7.4 REPLACEMENT THE ANTI-PUMPING VALVE

- 1) Take out the anti-pumping valve from the cap, operating on the outward part of the cap;



- 2) Use 3 drops of Loctite 495 on the bottom of the cap seat for the new anti-pumping valve;



- 3) Place and insert the new anti-pumping valve in the cap seat with the two holes, present on one side of the anti-pumping valve, headed outwards;



- 4) Force the inserting of the anti-pumping valve into the seat with a light blow.



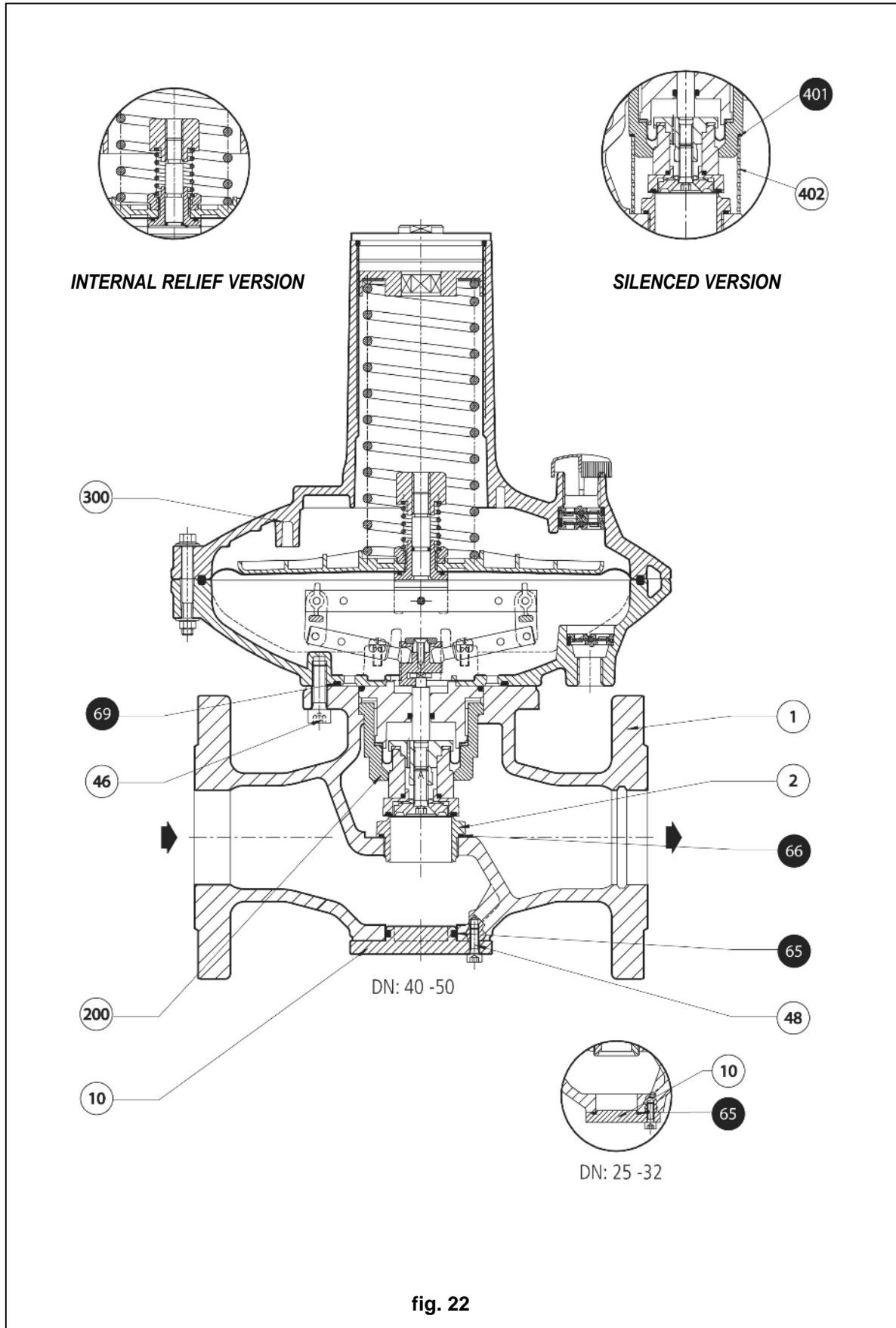

fig. 22

Gruppo 300

fig. 23
Standard head

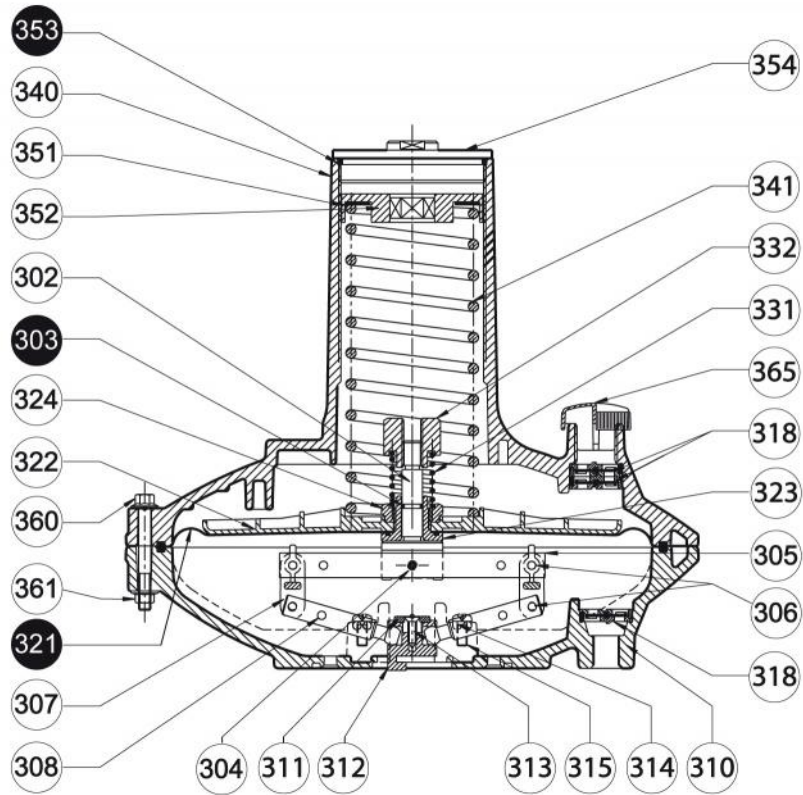
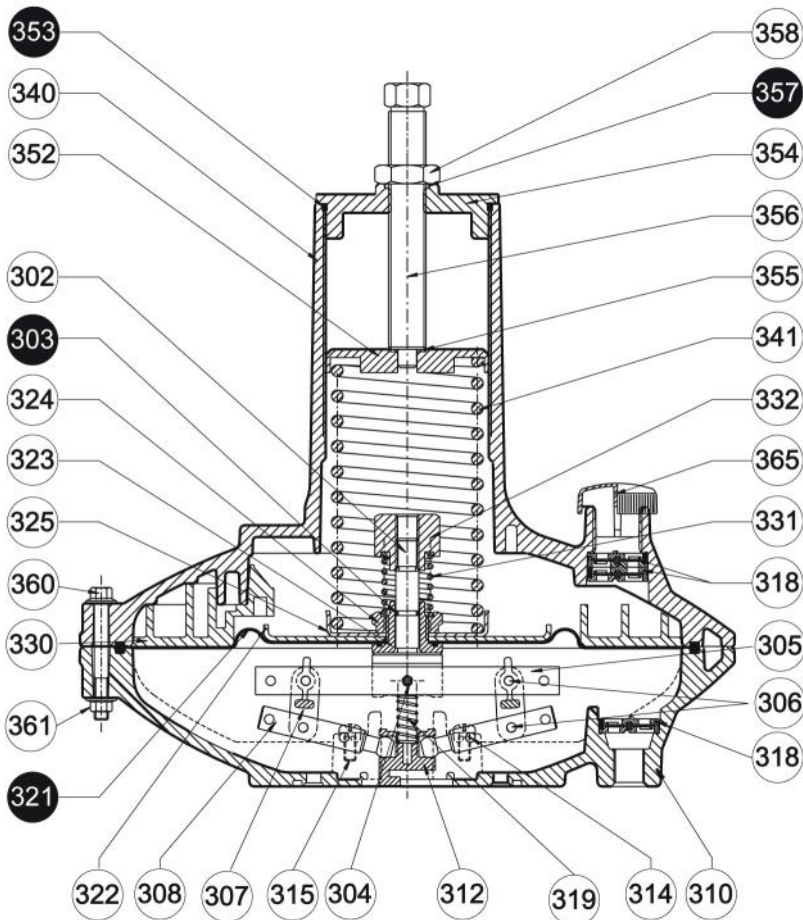

fig. 24
TR Head



Unit 200

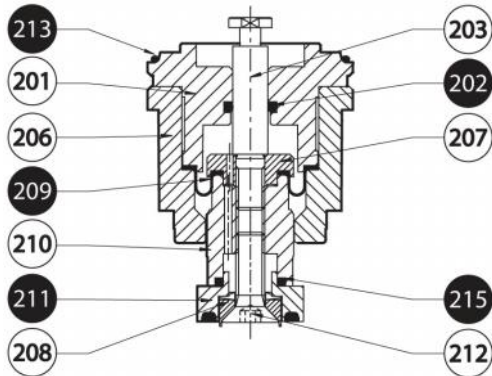

fig. 25a
(Standard version DN 25 e 32)

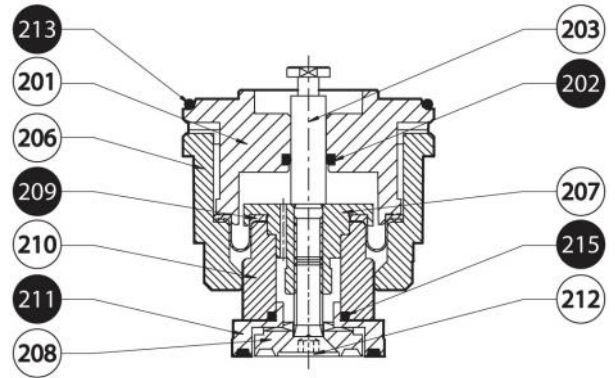

fig. 25b
(Standard version DN 40 e 50)

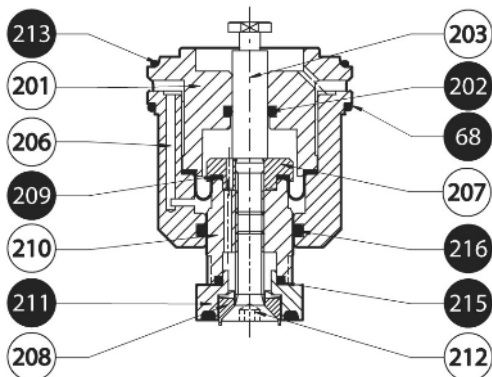

fig. 26a
(Monitor version DN 25 e 32)

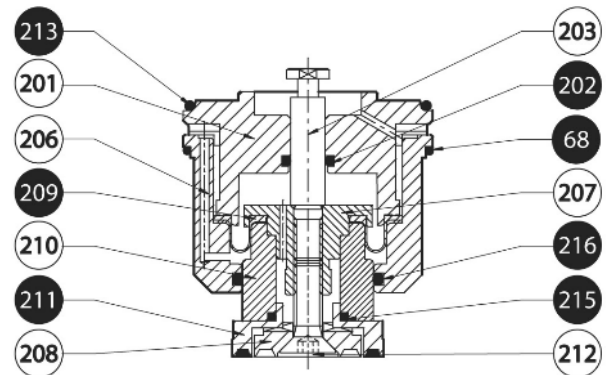

fig. 26b
(Monitor version DN 40 e 50)

7.5 LA:: SLAM SHUTH VALVE (fig. 27)

- 1) Make sure that the slam-shut valve is in closed position;
- 2) Disconnect the fittings between the slam-shut valve and the downstream pressure connection;
- 3) Remove the screws tightening the slam-shut valve to the body;
- 4) Unscrew the plug (20) and the regulation nuts (17) and (18); then, extract the calibration springs (34) and (35) and the spring supports (12) and (13);
- 5) Remove the screws (41) and disassemble the cover (2) with the nut (14);
- 6) Extract from the body (1) the diaphragm assembly consisting of the parts 45, 46, 48, and 49; to separate them, unscrew the pin (45) from the tightening nut (49);
- 7) Remove the nut (37) and unscrew the nut (6) and the threaded bush (7) completely;

- 8) From the upper part, extract the shaft assembly consisting of the parts 9, 66, 19, 4 and 8, the bushes (22) and (23) and (19), and the shaft (5). Then, unscrew the shaft (5) and the obturator support (4), and remove the spring ring (9) to disassemble the obturator (19);
- 9) Remove the screws (40) and disassemble the anchoring assembly consisting of the parts 29, 30, 33, 36, 38, 39, and 43;
- 10) Remove the screws (53) to disassemble the flange (51);
- 11) Finally, to disassemble the release button assembly, unscrew the nut (61) and then unscrew the part (58) from the pin (62).

To reassemble the slam-shut it is possible to carry out the disassembly operations in the inverse order.
Before reassembling the sealing elements (O-rings, diaphragms, etc.), check their integrity and replace them if necessary.

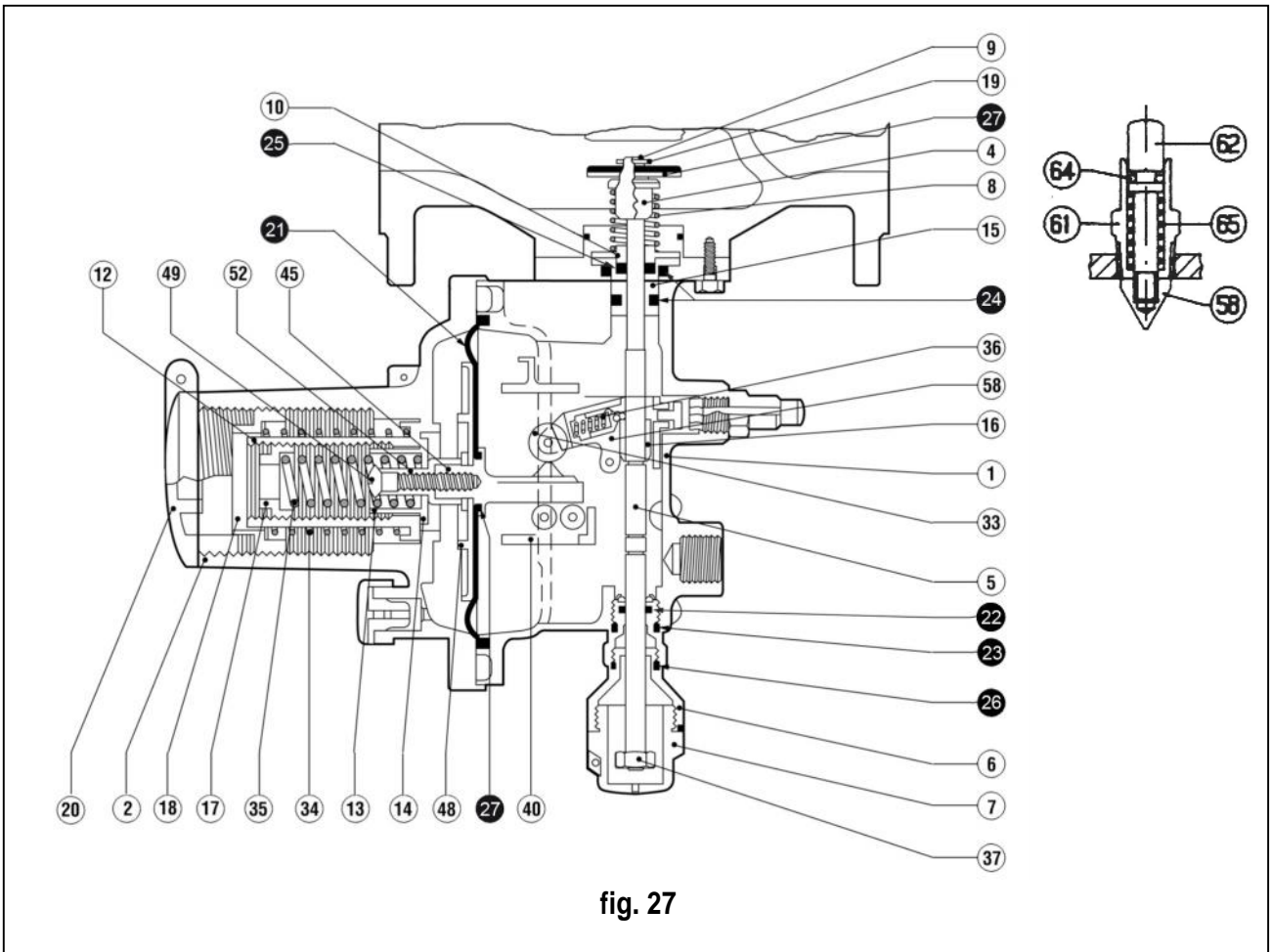

fig. 27

8.0 FINAL OPERATION







8.1 CHECKING THE TIGHTNESSES

- 1) Very slowly open the on/off valve upstream from the regulator and using a foam solution or the like check:
 - the tightness of the external surfaces of the regulator;
 - the tightness of the slam-shut;
 - the tightness of the internal surfaces of the regulator;
 - the tightness of the fitting.
- 2) Operating very slowly, pull the provided threaded bushing (7), off the slam-shut until only the internal by-pass is opened. Pull completely to the re-engage position;
- 3) Check the tightness of the reinforced gasket of the regulator;
- 4) Open a bleed cock downstream from the regulator to create a small gas flow;
- 5) Turn the internal adjustment ring (352) until the desired set-point value is reached;
- 6) Close the bleed cock to the atmosphere.

8.2 START UP

- 1) Very slowly open the downstream on/off valve and, if necessary, adjust the regulator set-point by means of the internal adjustment ring (352).
- 2) Set the tap (354) for normal control head or the blocking screw nut (358) for reduced control head.

Tab. 10 MAINTENANCE WRENCHES FOR DIVAL 600 (+LA...) PRESSURE REGULATORS

		
Combination spanner	Adjustable spanner	Compass pin wrench
Ch. 8-9-10-11-12-13-14-15-16-17-18-19-20-21-22-23-24-25-26-27-41	L. 30	Ch. 8-9-10-11-12-13-14-15-16-17-18-19-20-24-26-27-36-46
		
Hexagon or allen Key	Philips screwdriver	Flat head screwdriver
Ch. 3-4-5-6-7-8-19	Es.Ch PH 0 x 100 - PH 1x125 – PH 2x150	0,5x3x75 1,2x6,5x125
		
Circlip pliers		
Cod.10÷25 19÷60		



Pietro Fiorentini S.p.A.
via E.Fermi 8/10
I-36057 Arcugnano (VI) Italy

Tel. +39 0444 968.511
Fax. +39 0444 960.468

www.fiorentini.com

via Rosellini 1
I-20124 Milano
Italy

Tel. +39 02 696.14.21
Fax. +39 02 688.04.57

MT185-E January 2012