

REVAL

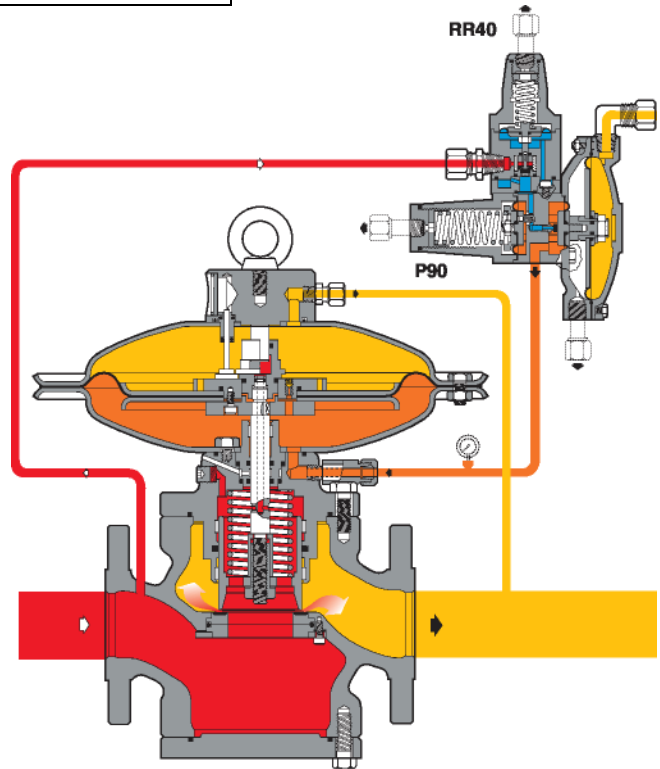

- *Top Entry Design for ease of maintenance*
- *Pilot Operated Regulator for Low and Medium Pressure*
- *“Fail Closed” or “Fail Open” design*
- *Inlet Pressure Range: 7 to 232 psig*
- *Ratings: ANSI 125 and 150*
- *Connections FF, RF*
- *Body Materials: Ductile Iron and Cast Steel*
- *Sizes: 1”, 1 ½”, 2”, 2 ½”, 3”, 4”, 6”, and 8”*
- *Flow Coefficient (Nat. Gas): Kg range 1755 to 5954*
- *Maximum Capacity: 50,600 to 1,798,000 SCFH*

- *Outlet Pressure Range: 3” w.c. To 174 psig (depending on Installed Pilot)*

OPTIONS:

- *SB 82 – Integral Slam-Shut valve*
- *PM 182 – Integral Pilot Operated “Fail to Close” Monitor*
- *DB 182 – Integral Silencer*

