

**Model RTR®**

**Recordall® Transmitter Register**

# Technical Brief

## DESCRIPTION

**APPLICATIONS:** The Recordall® Transmitter Register (RTR®) is designed for use with all Recordall Disc, Turbo, Compound and Fire Service Meters to provide output compatibility with ORION®, Itron® ERT®, TRACE®, and Badger Meter, Inc. approved AMR technology solutions.

**RESOLUTION:** Digital output from the RTR typically has resolution of 1/10th of the register test circle (resolution may vary in some cases). The electronic resolution table in this brochure lists minimum output resolution for all Recordall meter applications.

**MOUNTING:** The RTR in its shroud assembly uses a bayonet mount compatible with all Recordall disc and turbo II meters. A TORX® seal screw is provided to allow positioning of the register for the most convenient reading and to secure the register to the meter body in a tamper resistant mode. The RTR can be removed from the meter without disrupting water service.

**MAGNETIC DRIVE:** Direct drive high-strength magnetic coupling through the meter body to the wetted magnet provides reliable and dependable register coupling.

**SEALED REGISTER:** The RTR local register consists of a six-digit straight-reading mechanical odometer totalizer (located in the six o'clock position), a 360° test circle with sweep hand, and a flow finder to detect leaks. The register gearing is self-lubricating thermoplastic to minimize friction and provide long, reliable life. Permanent sealing eliminates moisture, dirt, and other contaminants. (The leak rate of the seal is less than 10<sup>-6</sup> cc/sec as tested by a helium mass spectrometer.)

**TAMPER-PROOF FEATURES:** Customer removal of the RTR can be prevented by using a tamper resistant TORX seal screw. Torx seal screws are provided as standard accessories with the RTR. Optional tamper detection seal wire screws are also available.

**CONSTRUCTION:** The housing of the RTR is constructed of a strengthened glass lens top and a copper alloy metal bottom. Internal construction materials are thermoplastics for long-life and high reliability. The integrity of the adhesive seal joining the glass top to the metal base provide unmatched protection in water meter applications. A corrosion and tamper resistant Torx seal screw is provided to secure the RTR to the meter. The shroud assembly is thermoplastic.

**TEMPERATURE:** The operating range of the RTR is -40° C to 49° C (-40°F to 120°F). The water meter should not be subjected to temperatures below freezing.

**MOISTURE:** The RTR achieves true water resistance due to the adhesive technology used in the sealing process. Leak rates less than 10<sup>-6</sup> cc/sec. as tested by a helium mass spectrometer, are comparable to a true hermetic seal. Due to this unique sealing process, the RTR exceeds all applicable requirements of AWWA Standard C707 regarding moisture intrusion. Register fogging and condensation are no longer an issue.

**WIRE CONNECTIONS:** The RTR is provided as either a factory prewired assembly or as a register with pre-sized wire harness available for connection in the field.

**ELECTRONICS:** The piezoelectric switch circuit board is completely sealed against moisture inside the unit and sealed to ensure protection from humidity.

**ELECTRICAL:** The electronic circuitry is designed to provide immunity to electrical surges and transients per IEC801-2, IEC801-4 Severity Level 4.



## SPECIFICATIONS

<b>Transmitter/Register</b>	Straight reading, permanently sealed, magnetic drive
<b>Unit of Measure</b>	U.S. Gallons, Cubic Feet, Cubic Meters, clearly identified on register face
<b>Number Wheels</b>	Six with 3/16" high numerals font type
<b>Test Circle</b>	360° circle with ten major increments with ten divisions each
<b>Weight</b>	9 Ounces
<b>Humidity</b>	0% to 100% Condensing
<b>Temperature</b>	-40°C to 49°C (-40°F to 120°F)
<b>Signal Characteristics</b>	Open Drain (FET)
<b>Visual Resolution</b>	1/100th of Test Circle
<b>Electronic Resolution</b>	1/10th of Test Circle
<b>Typical Signal Duration</b>	15 ms to 75 ms @ 25°C (77°F) 8 ms to 75 ms over operating temperature range at 67 µA
<b>On State Resistance</b>	7.5 Ohms @ 25°C (77°F)
<b>Power Source</b>	External
<b>Maximum Switching</b>	30 VDC @ 1 mA @ 25°C (77°F)

**OPERATING CHARACTERISTICS:** The RTR has an output equal to 1/10th of the meter test circle with the characteristics of an open drain FET. The on-state condition is a solid-state switch closure. Off-state condition is an open circuit. Powered by an external source, the RTR has a maximum rating of 30 VDC at 1 mA (25°C).

Itron® and ERT® are a registered trademarks of Itron, Inc. TRACE® is a registered trademark of American Meter Company. Badger®, Recordall®, RTR® and ORION® are registered trademarks of Badger Meter, Inc. TORX® is a registered trademark of Camcar, Division of Textron, Inc.



**BadgerMeter, Inc.**

**RTR-T-05**

10-03

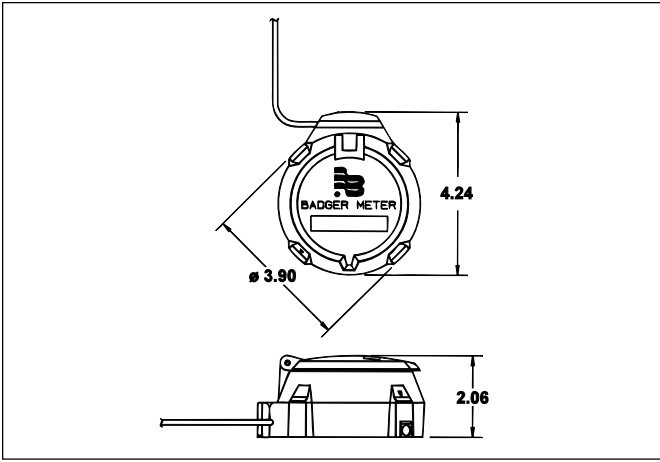

Dimensional Drawing

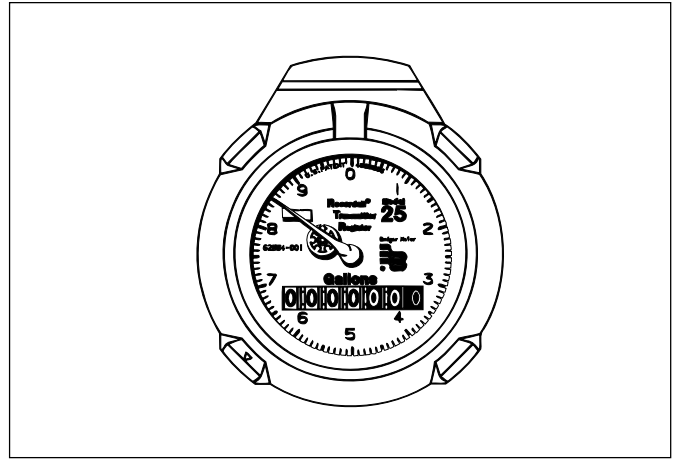

RTR Register

**MEASUREMENT RESOLUTION:** The minimum electronic resolution of the RTR is as noted below. To verify the correct resolution for your application, contact your Badger Meter regional sales office.

RECORDALL® Disc Series	Size	Resolution Gallons	Resolution Cubic Feet (Ft³)	Resolution Cubic Meters (m³)
M25	5/8"	1	0.1	0.01
M25	3/4"	1	0.1	0.01
M35	3/4"	1	0.1	0.01
M40	1"	1	0.1	0.01
M70	1"	1	0.1	0.01
M120	1 1/2"	10	1	0.1
M170	2"	10	1	0.1

RECORDALL Turbo Series	Resolution Gallons	Resolution Cubic Feet (Ft³)	Resolution Cubic Meters (m³)
1 1/2"	100	10	0.1
2"	100	10	0.1
3"	100	10	0.1
4"	100	10	0.1
6"	100	10	1
8"	100	10	1
10"	100	10	1
12"	1000	100	1
16"	1000	100	10
20"	1000	1000	10

Fire Service Meters	Resolution Gallons	Resolution Cubic Feet (Ft³)	Resolution Cubic Meters (m³)
3"	100	10	0.1
4"	100	10	0.1
6"	100	10	1
8"	100	10	1
10"	100	10	1

RECORDALL Compound Series	Resolution Gallons	Resolution Cubic Feet (Ft³)	Resolution Cubic Meters (m³)
2"	100	10	0.1
3"	100	10	0.1
4"	100	10	0.1
6"	100	10	1

Resolution stated as summed total with (2) RTRs, Summator/Splitter and a single AMR module. Please see the Turbo Series and Disc Series sections for individual high and low side resolution.

Fire Series Assemblies (FSA)	Resolution Gallons	Resolution Cubic Feet (Ft³)	Resolution Cubic Meters (m³)
4"	100	10	0.1
6"	100	10	1
8"	100	10	1
10"	100	10	1

Resolution stated as summed total with (2) RTRs, Summator/Splitter and a single AMR module. Please see the Turbo Series and Disc Series sections for individual mainline and by-pass resolution.

**CAUTION**

The RTR® should only be connected to a Badger Meter, Inc. approved product. Connection to an unapproved product will void the RTR warranty.

Due to continuous research, product improvements and enhancements, Badger Meter reserves the right to change product or system specifications without notice, except to the extent an outstanding bid obligation exists.



Please see our website at  
[www.badgermeter.com](http://www.badgermeter.com)  
 for specific contacts.



**BadgerMeter, Inc.**

P.O. Box 245036, Milwaukee, WI 53224-9536  
 (800) 876-3837 / Fax: (888) 371-5982  
[www.badgermeter.com](http://www.badgermeter.com)