



Badger Meter

Recordall® Transmitter Register (RTR®) Remote Electronic Display (RED)

APPLICATION

The Model RED Remote Electronic Display unit is designed to provide remote visual readings when connected directly to any of Badger's Recordall® Transmitter Registers (RTR®). The RED is used to read compatible RTR transmitters that are not easily accessible or are in difficult to read locations. Installations such as inside houses or buildings, meter vaults, or dangerous industrial locations are ideal for the RED. The RED can also be used when old style generators have been replaced with RTR style transmitters to provide dependable remote readings.

OPERATION

The Model RED is a battery operated device. When attached to any of Badger's RTR transmitters it is designed to provide the same output resolution as the RTR. To conserve battery life the LCD is awakened only when the internal membrane switch has been activated. This is easily accomplished by tapping the target circle on the register display. This will bring up the meter's current reading for 20 seconds, after which the display will return to the sleep mode. The RED is easily programmable in the field by tapping of a PIN number on the front of the display. The RED will display and increment all digits of the RTR register including the sweep hand position, but will use a decimal point to show which are significant for billing purposes. Billing digits are those to the left of the decimal point

OPERATING PERFORMANCE

The Model RED meets AWWA Standard C706 for direct-reading remote registration systems.

TAMPER-PROOF FEATURES

The Model RED is supplied with an anti-tamper indicator that detects both open and short circuit conditions. Any time the connection is interrupted a visual alarm appears on the display (tamper designated as an "E" appears in the far left side of the reading.) To reset the tamper, the RED must be reprogrammed. The unit is also supplied with a tamper resistant TORX® seal screw to prevent access to the unit.



MAINTENANCE

There is no maintenance since the electronics and battery are encapsulated and not accessible.

FEATURES

- Environmentally sealed
- Field programmable
- Tamper indicator
- One model usable with any Badger® meter equipped with an RTR
- Mounts on Badger ROM Footprint
- TORX® seal screw security
- Membrane "TAP" switch for viewing
- 10 year projected battery life



SPECIFICATIONS

Operating Temperature	-13 to 140°F (-25 to 60°C)
Meter Compatibility	Any Badger meter equipped with an RTR; and Magnetoflow® mag meters
Connectivity	All Badger RTR transmitter and summator/splitter products
Dimensions	L 4.25" x W 3.9" x H 1.6"
Weight	0.3 Lbs.
Display	LCD, 8 characters .25 inches high; 7 digits for meter reading plus 1 character for system indicators
Power	(1) AA cell battery
Construction	High impact thermoplastic, weather and UV resistant
Wire Size & Distance	Utilizes a RTR connecting cable up to 75 feet long (available from the factory).

DIMENSIONS

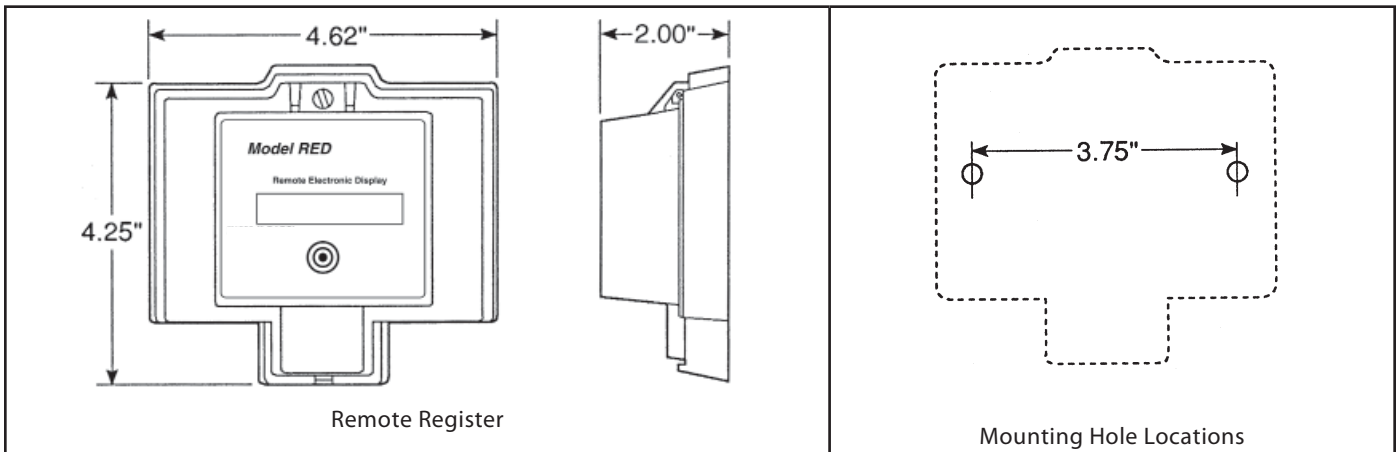

Recordall® and RTR® are registered trademarks of Badger Meter, Inc.
Copyright 2010, Badger Meter, Inc. All rights reserved.



Due to continuous research, product improvements and enhancements, Badger Meter reserves the right to change product or system specifications without notice, except to the extent an outstanding contractual obligation exists.

Badger Meter | P.O. Box 245036, Milwaukee, Wisconsin 53224-9536
800-876-3837 | infocentral@badgermeter.com | www.badgermeter.com