

FB-3500 BI-DIRECTIONAL ELECTROMAGNETIC FLOW METER
Installation and Operation Guide



SAFETY INFORMATION

This meter was calibrated at the factory before shipment. To ensure correct use of the meter, please read this manual thoroughly.

Regarding this Manual:

- This manual should be passed on to the end user.
- Before use, read this manual thoroughly to comprehend its contents.
- The contents of this manual may be changed without prior notice.
- All rights reserved. No part of this manual may be reproduced in any form without ONICON's written permission.
- ONICON makes no warranty of any kind with regard to this material, including, but not limited to, implied warranties of merchantability and suitability for a particular purpose.
- All reasonable effort has been made to ensure the accuracy of the contents of this manual. However, if any errors are found, please inform ONICON.
- ONICON assumes no responsibilities for this product except as stated in the warranty.
- If the customer or any third party is harmed by the use of this product, ONICON assumes no responsibility for any such harm owing to any defects in the product which were not predictable, or for any indirect damages.

Safety Precautions:

The following general safety precautions must be observed during all phases of installation, operation, service, and repair of this product. Failure to comply with these precautions or with specific WARNINGS given elsewhere in this manual violates safety standards of design, manufacture, and intended use of the product. ONICON Incorporated assumes no liability for the customer's failure to comply with these requirements. If this product is used in a manner not specified in this manual, the protection provided by this product may be impaired.

The following symbols are used in this manual:



WARNING

Messages identified as "Warning" contain information regarding the personal safety of individuals involved in the installation, operation or service of this product.



CAUTION

Messages identified as "Caution" contain information regarding potential damage to the product or other ancillary products.



IMPORTANT NOTE

Messages identified as "Important Note" contain information critical to the proper operation of the product.

TABLE OF CONTENTS

1.0	INTRODUCTION	5
1.1	PURPOSE OF THIS GUIDE	5
1.2	TYPICAL INSERTION ELECTROMAGNETIC FLOW METER	5
1.3	STANDARD FEATURES AND SPECIFICATIONS.....	6
1.4	ADDITIONAL REQUIRED HARDWARE.....	7
1.5	ADDITIONAL HARDWARE THAT MAY BE REQUIRED.....	8
1.5.1	Grounding Rings	8
2.0	UNPACKING	9
2.1	CHECKING THAT YOU HAVE RECEIVED EVERYTHING	9
3.0	INSTALLATION, REMOVAL & ADJUSTMENT	10
3.1	INSTALLATION SITE SELECTION	10
3.1.1	General Site Selection Guidelines	10
3.1.2	Insufficient Straight Run Site Selection Guidelines.....	11
3.2	MECHANICAL INSTALLATION.....	12
3.2.1	Installation Kit	13
3.2.2	ONICON Standard Installation Hardware Kit	13
3.2.3	ONICON Hot Tap Installation Hardware Kit	13
3.2.4	Customer Supplied Installation Hardware	14
3.2.5	Confirming the Stack Height	15
3.2.6	Installing the Flow Meter	16
3.3	INSERTION OF THE METER.....	17
3.3.1	Inserting the Flow Meter	17
3.4	REMOVAL OF THE METER.....	18
3.5	WIRING CONNECTIONS	20
3.5.1	Signal & Power Wiring Connections	21
3.5.2	Earth Connections.....	22
4.0	START-UP & COMMISSIONING FOR ONICON INSERTION ELECTROMAGNETIC FLOW METERS.....	23
4.1	HELPFUL HINTS FOR START-UP AND COMMISSIONING.....	23
4.2	START-UP AND COMMISSIONING	24
4.3	START-UP AND COMMISSIONING WORKSHEET	25
4.4	TROUBLESHOOTING GUIDE.....	26
4.4.1	Earth Connections & Electrical Noise Reduction	26

APPENDIX

Conditions of Sale

SECTION 1.0: INTRODUCTION

We, at ONICON Incorporated, would like to thank you for purchasing our quality American made FB-3500 Bi-Directional Electromagnetic Flow Meter. As our valued customer, our commitment to you is to provide fast reliable service, while continuing to offer you quality products to meet your growing flow measurement needs.

1.1 PURPOSE OF THIS GUIDE

We have written this guide to provide the persons responsible for the installation, operation and maintenance of your flow meter with the most specific equipment information they will need. This is NOT an electrical or plumbing trade manual.



WARNING

Please do not permit persons to install, operate or maintain this equipment unless they have a complete knowledge of their trade skills and are competent to work on high pressure hot and cold water and steam systems, according to their individual trades. Death or permanent injury may result from accidents with these systems.

This guide is the basic reference tool for all ONICON FB-3500 Bi-Directional Electromagnetic Flow Meters. If you have not purchased all of the options, there will be references in this manual which are not applicable to your meter(s).

1.2 TYPICAL INSERTION ELECTROMAGNETIC FLOW METER

Faraday's Law of electromagnetic induction states that a voltage will be induced in a conductor when it passes through a magnetic field, and the induced voltage will be directly proportional to the velocity of the conductor.

ONICON FB-3500 Bi-Directional Electromagnetic Flow Meters generate pulsating magnetic fields that are used to induce a voltage into the conductive fluid flowing through the pipe. Electrodes located on the flow meter sensor head measure the induced voltage. Circuitry within the flow meter electronics enclosure then converts the voltage to digital and analog signals that convey flow rate and total data via connecting the cable to any of ONICON's display devices, Btu meters and/or to a data acquisition system.

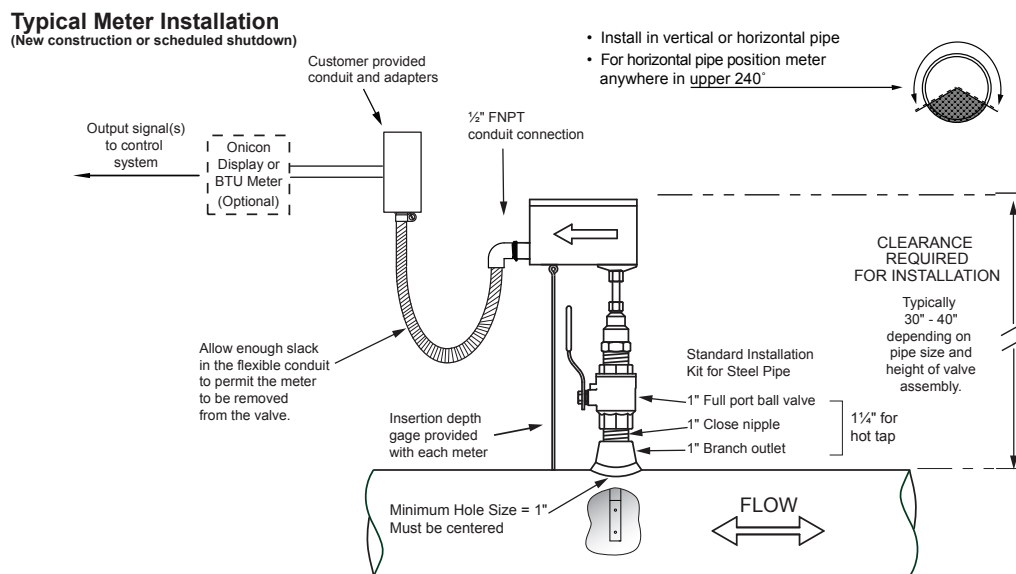

Note: Installation kits vary based on pipe material and application. For installations in pressurized (live) systems, use "Hot tap" 1/4 inch installation kit and drill hole using a 1 inch wet tap drill.

1.3 STANDARD FEATURES AND SPECIFICATIONS

Accuracy

- ± 1.0% of reading from 2 to 20 ft/sec
- ± 0.02 ft/sec below 2 ft/sec

Sensing Method

Electromagnetic, no moving parts

Pipe Size Range

3" through 72" nominal

Input Power

- 20 - 28 VAC 50/60 Hz, 250 mA maximum
- 20 - 28 VDC, 250 mA maximum

Liquid Temperature Range

15° to 250° F

Ambient Temperature Range

-5° to 150° F

Operating Pressure

400 PSI maximum

Pressure Drop

Less than 0.1 psi at 12 ft/s velocity in 3" and larger pipes

Materials of Construction

- Wetted metal components - 316L stainless steel
- Sensor head - Polypropylene
- Electronics enclosure - Powder coat painted cast aluminum

Enclosure Rating

Weathertight, NEMA 4

Electrical Connections

10' of PVC jacketed cable with ½" NPT conduit connection

OUTPUT SIGNALS PROVIDED

Analog Output (Isolated)

Selectable: 4-20 mA, 0-10 V or 0-5 V

Frequency Output

0 – 15 VDC, 0 – 500 Hz

Pulse/Contact Closure Outputs (four)

Isolated solid state dry contact
Contact maximum ratings: 100 mA, 50 VDC

Scalable Pulse Outputs (two)

Forward & Reverse Flow Totalization
Pulse Duration: 0.5, 1, 2 or 6 seconds

Directional Contact Output:

Switch closed when flow is in direction of flow arrow on enclosure
Latches at 0.2 ft/s
Switches within 20 seconds of direction change

Master Alarm Output:

Switch closed indicates alarm condition

This product is covered by one or more of the following patents: 6,431,011 and 6,463,807.

1.4 ADDITIONAL REQUIRED HARDWARE

All ONICON insertion type meters can be installed and removed via a 1" or larger full port ball valve without system shutdown. The terms "Standard" and "Hot Tap" refer to the installation method of the isolation valve kit only.

Standard Installation Hardware: For new construction or scheduled shutdown, once kit is installed, the flow meter can be installed or removed without system shutdown.

Hot Tap Installation Hardware: For applications which require the access hole in the pipe to be drilled through the valve using a wet tap drilling machine while the hydronic system is pressurized and operating.

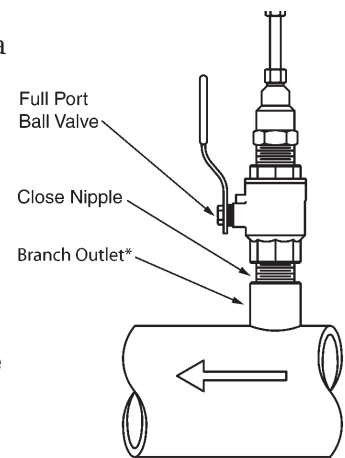

*Weld-on fitting, copper tee or saddle

NOTE: Installation hardware materials vary greatly based on pipe material, pipe size and standard vs. hot tap versions.

1.5 ADDITIONAL HARDWARE THAT MAY BE REQUIRED

1.5.1 Grounding Rings

Grounding rings may be required whenever meters are installed in non-metallic or lined pipes. Grounding rings placed before and after the meter eliminate electrical noise that will interfere with the proper operation of the meter. ONICON provides grounding rings as an optional accessory. Grounding ring dimensional information and part numbers are listed below. For proper operation, grounding rings are required before and after the meter.

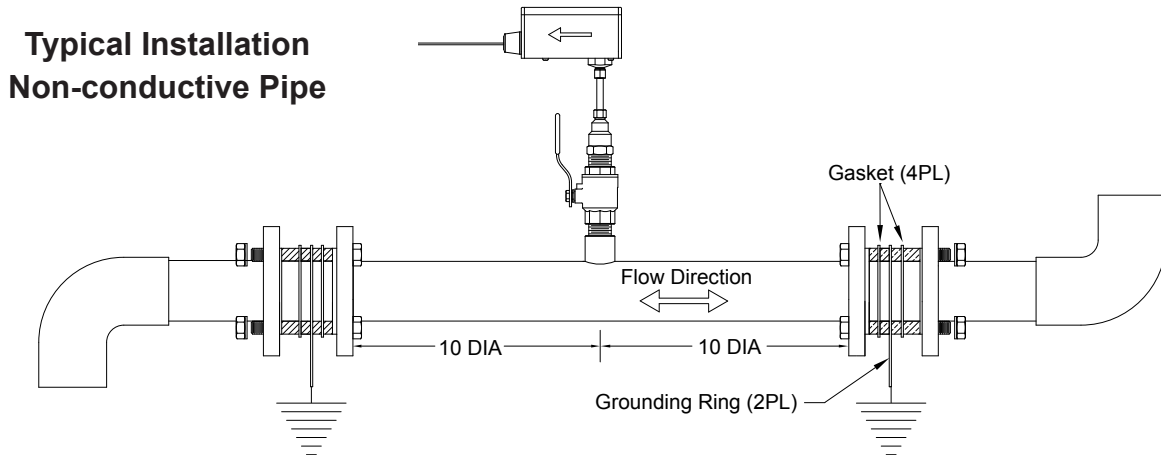

DIMENSIONS

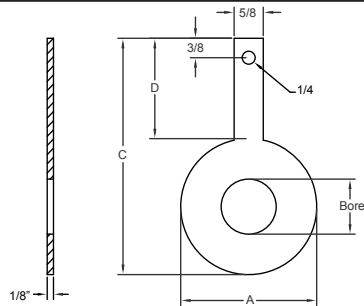

Grounding Ring Dimensions				
Nominal Size	Bore	A	C	D
1"	1 - 1/16	2 - 5/8	4 - 9/16	1 - 15/16
1.5"	1 - 9/16	3 - 3/8	5 - 5/16	1 - 15/16
2"	2 - 1/16	4 - 1/8	6 - 1/16	1 - 15/16
3"	3 - 1/16	5 - 3/8	7 - 5/16	1 - 15/16
4"	4 - 1/16	6 - 7/8	8 - 13/16	1 - 15/16
6"	6	8 - 3/4	10 - 11/16	1 - 15/16
8"	8	11	12 - 15/16	1 - 15/16
10"	9 - 1/2	13 - 3/8	15 - 5/8	2 - 1/4
12"	11 - 9/16	16 - 1/8	18 - 9/16	2 - 7/16
14"	13 - 1/2	17 - 3/4	20 - 3/8	2 - 5/8
16"	15 - 1/4	20 - 1/4	22 - 7/8	2 - 5/8
18"	17 - 3/8	21 - 5/8	24 - 1/4	2 - 5/8
20"	19	23 - 7/8	26 - 11/16	2 - 13/16
24"	23	28 - 1/4	31 - 1/8	2 - 7/8
30"	29	34 - 3/4	38	3 - 1/2
36"	35	41 - 1/4	45 - 1/4	4
42"	41	48	52 - 1/2	4 - 1/2

ORDERING INFORMATION

ANSI Class 150 316 Stainless Steel Grounding Rings (pair)	
Nominal Size	ONICON Part Number
1"	19265
1½"	19266
2"	19267
3"	19268
4"	19269
6"	19270
8"	19271
10"	19272
12"	19273
14"	19274
16"	19275
18"	19276
20"	19277
24"	19278
30"	19279
36"	19280
42"	19281

SECTION 2.0: UNPACKING

ONICON insertion magnetic flow meters are packed and shipped in individual cartons. An optional installation hardware kit INSTL 1 or INSTL 2, if ordered, will be packaged with each meter. All other installation hardware and peripheral devices, including Btu meters and display modules, will be packaged and shipped separately.

Please open all packages with care to prevent damage to their contents. Carefully inspect each item for signs of damage in transit. The flow meter stem should be straight and free of blemishes or abrasions. The sensor head should have a smooth continuous surface that is free of abrasions.

All ONICON products are shipped insured unless the customer specifically requests otherwise. Please notify the shipping company and ONICON immediately if any items are damaged in transit. Save all packing material for inspection by the shipper.

2.1 CHECKING THAT YOU HAVE RECEIVED EVERYTHING

- **Standard Documentation**

Enclosed with each meter is a comprehensive documentation package that includes the following items:

Installation and Operation Guide
Flow Meter Certificate of Calibration

Please notify the ONICON if any of these documents are missing.

FB-3500 Bi-Directional Insertion Electromagnetic Flow Meter
Optional INSTL1 or INSTL2 Installation Hardware Kit, if ordered

SECTION 3.0: INSTALLATION, REMOVAL AND ADJUSTMENT



WARNING

Insertion flow meters may be installed in pipes which are under high pressure. Accidents with these systems can cause serious injury or death. Only persons experienced with high pressure systems and related knowledge in the heating, cooling and fluid metering fields should attempt to install, adjust, or remove the flow meter. Please read all instructions before attempting to insert or remove a flow meter.

ONICON will be happy to assist with technical recommendations and to provide guidance by telephone or e-mail. On-site field engineering, installation and service is also available at additional cost.

3.1 INSTALLATION SITE SELECTION

Install the flow meter where it will be accessible for personnel to perform necessary periodic maintenance. The clearance required for installation is typically 30”- 40” from the pipe wall to the nearest obstruction above the valve assembly. This clearance dimension will increase with large diameter pipes. The environment should be free of corrosive liquids/fumes, temperature extremes and heavy vibration. The following diagrams should be used as a guide to the proper location for installing the meter.

3.1.1 General Site Selection Guidelines

GENERAL PRACTICES:

1. For best results, install the flow meter in a straight run of pipe, free of bends, tees, valves, transitions and obstructions.
2. Straight run recommendations vary based on the nature of the upstream obstruction. See the table below for guidelines in determining upstream straight run recommendations based on the nature of the obstruction. Please note that depending upon specific location details, more or less straight run may be required to produce a satisfactory flow profile.

For 3” and larger pipe diameters

Obstruction on either side of meter	Straight run distance recommended between meter and obstruction
Single bend preceded by ≥ 9 diameters of straight pipe	10 Diameters
Pipe size reduction / expansion in straight pipe run	10 Diameters
Single bend preceded by ≤ 9 diameters of straight pipe	15 Diameters
Outflowing tee / pump outflow	20 Diameters
Multiple bends out of plane	30 Diameters
Inflowing tee	30 Diameters
Control / modulating valve	30 Diameters

How To Determine The Available Straight Pipe Diameters:

For each application, locate the longest straight, unobstructed section of pipe (no bends, tees, valves, other insertion probes, size transitions).

The longest straight pipe run in inches divided by nominal pipe size in inches equals "diameters of straight pipe."

For closed loop applications, consider both the supply and return lines as possible locations.

IMPORTANT NOTE

Always use the maximum available straight run. When more than the minimum required straight run is available, place the meter such that the excess straight run is maximized on both sides of the meter location.

- Acceptable to install in vertical pipe
- Position meter anywhere in upper 240° for horizontal pipe

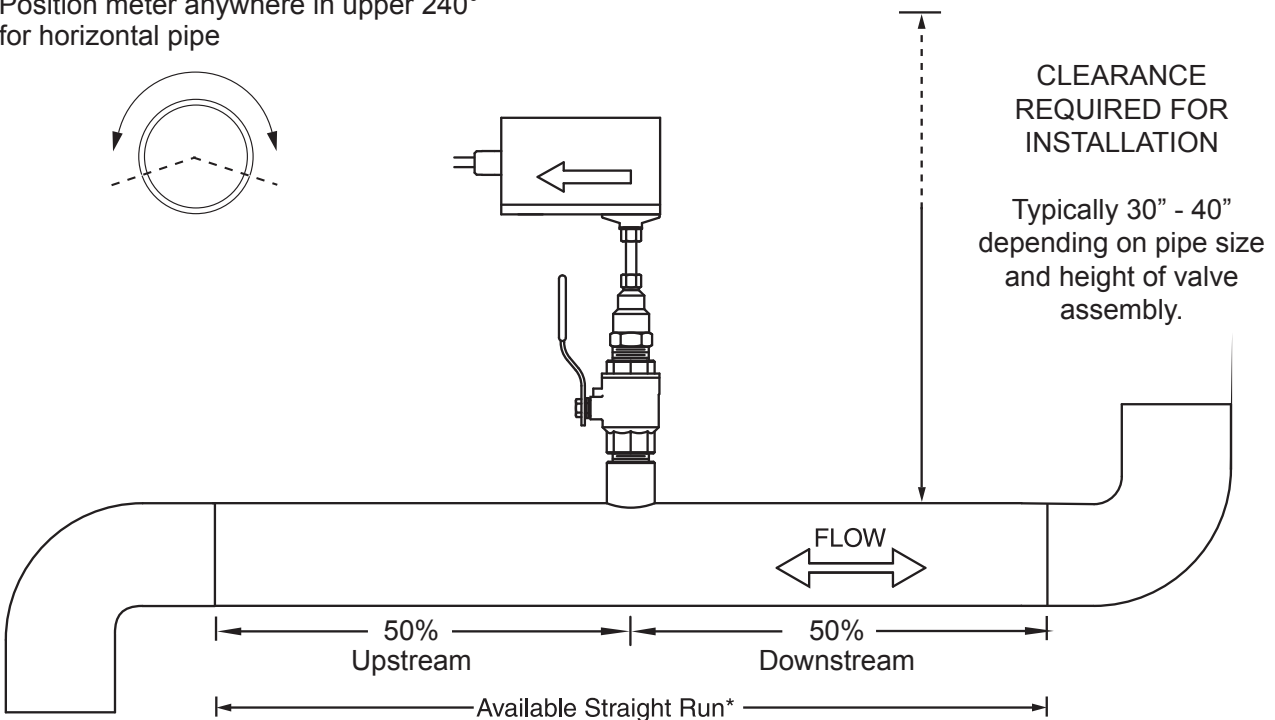

3.1.2 Insufficient Straight Run Site Selection Guidelines

If there is insufficient available straight run, allow 50% of the run upstream and 50% of the run downstream. If the total length of straight run is less than 20 diameters, performance may degrade and consideration should be given to changing to the F-3100 or F-3200 In-Line Electromagnetic Flow Meters.

Some installations may work better with straight run optimized for flow in one direction. For example, with flow meters installed in the bypass line between de-coupled constant volume primary and variable secondary loops, it may be more important to accurately measure positive flow (from supply to return.) Negative flow measurements (from return to supply) are generally less critical, and it may be enough just to know that any negative flow is present. In this scenario, maximizing straight run for positive flow might be a preferred strategy.

3.2 MECHANICAL INSTALLATION

ONICON Insertion Electromagnetic Flow Meters employ a hot tap adapter design that allows for insertion and removal, when necessary, without interrupting flow and draining the pipe. To take advantage of this feature, the flow meter must be installed through an isolation valve. The installation must allow for sufficient overhead clearance to fully extract the meter, and a full 1" opening in the pipe wall is required to clear the sensor head and allow for insertion. Make sure that your valves and fittings are full port and at least 1" in actual internal diameter.

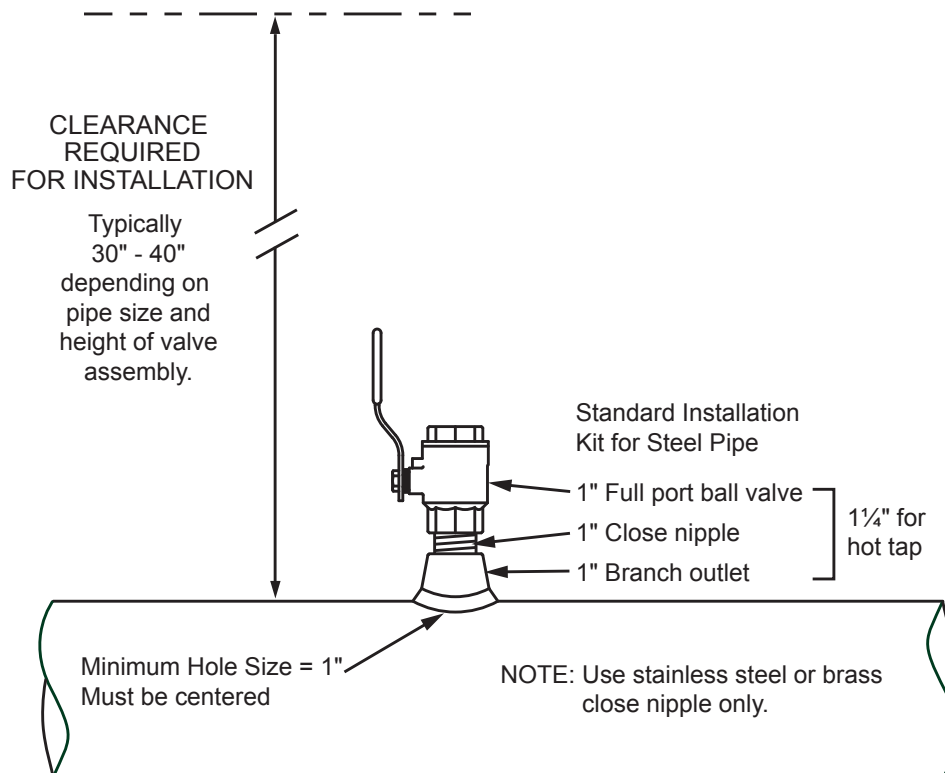

CAUTION



ONICON insertion style flow meters must be installed through a valve assembly. Failure to do so negates the ability to remove the meter without shutting down and draining the system. It will also result in an excessive amount of stem protruding from the pipe. Excessive stem lengths unnecessarily expose the meter to incidental damage.

IMPORTANT NOTE



Flow meters installed through oversized access holes will be subjected to undesirable turbulence that may affect the accuracy of the meter.

3.2.1 Installation Kit

ONICON offers a wide range of installation hardware kits for commonly used pipe materials. The kits are specifically designed for ONICON flow meters, and their use is recommended.

The use of ONICON installation hardware kits accomplishes two important objectives. First, it ensures that the proper hardware is used. Second, it simplifies order processing by standardizing the dimensions of the installation hardware. ONICON must have an accurate measurement of the overall height of the installation hardware as measured from the outside wall of the pipe to the top of the valve in order to determine the correct stem length when assembling the meter in our factory. ONICON documents refer to this dimension as the stack height.

ONICON installation hardware kits consist of three separate component parts:

Some type of threaded branch outlet,



An interconnecting close nipple,



And a full port isolation valve.



Different pipe materials require different branch outlets and may include additional bushings to properly size the opening.



3.2.2 Onicon Standard Installation Hardware Kit

Standard installation hardware kits are designed to be installed on piping systems that are drained and at atmospheric pressure. The access hole is drilled (1" minimum) prior to installation of the branch outlet with 1" NPT threads, close nipple and full port ball valve. Once the isolation valve is installed, the piping system can be flushed, filled and pressurized. The flow meter may now be inserted or removed by hand without having to drain the system. Please read all instructions before proceeding with meter insertion.

3.2.3 Onicon Hot Tap Installation Hardware Kit

ONICON offers an alternative installation hardware kit when it is not practical to relieve pressure and drain the system. In this case, a 1¼" branch outlet, close nipple and 1¼" full port ball valve are installed first. Then, a hot tap drilling apparatus is used to drill a 1" diameter hole through the valve. This eliminates the need to shut down and drain the pipe. Please read all instructions before proceeding with meter insertion.

3.2.4 Customer Supplied Installation Hardware

There are occasions where circumstances require that the customer provide the installation hardware or that the flow meter be installed through existing hardware. In these cases, it is important to confirm that the installation hardware is suitable for use with the flow meter provided by ONICON before it is installed. The installation must allow for sufficient overhead clearance to fully extract the meter and a full 1" opening in the pipe wall is required to clear the sensor head and allow for insertion. Make sure that your valves and fittings are full port and at least 1" in actual internal diameter.

Installation hardware generally consists of three separate component parts:

Some type of threaded branch outlet,



An interconnecting close nipple,



And a full port isolation valve.

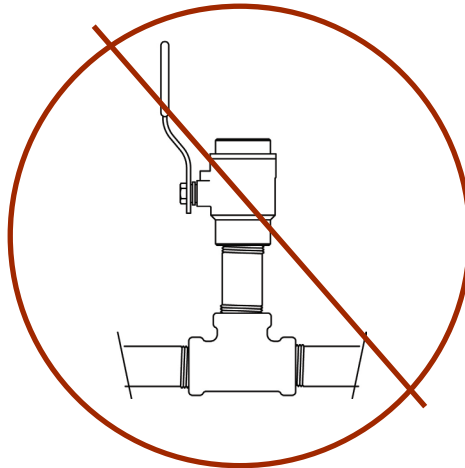

CAUTION

Do not use threaded steel or slip PVC tees to provide the 1" opening in the pipe. Tees of this type will cause significant errors in the flow measurement.



CAUTION

In order to provide the flow meter with the correct stem length, ONICON must know the overall height of the installation hardware as measured from the outside wall of the pipe to the top of the valve where the meter is installed.



CAUTION

Use stainless steel or brass nipple only.

3.2.5 Confirming the Stack Height

ONICON insertion flow meter stem lengths vary according to the pipe diameter and the height of the installation hardware stack. ONICON records the stack height dimension provided by the customer at the time of order entry, and the information is used to size the stem. The dimension is shown on the laminated insertion depth gage tag attached to the meter.

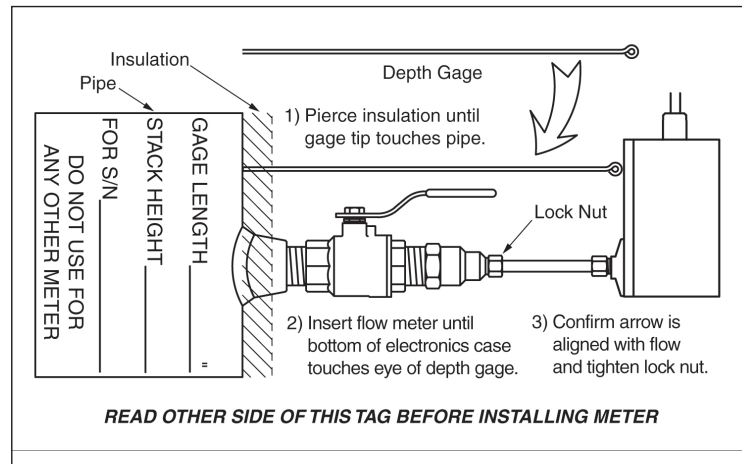

Prior to installing the meter, confirm that the stack height recorded on the tag is close to the actual stack height. Flow meter stems are intentionally over sized to allow for variations of at least 2" in the stack height. Contact ONICON prior to installation if there is any question regarding stack height or stem length. This way ONICON can offer you credit for your meter if you decide to exchange the meter for one with a different stem length. Returns may be subject to a restocking fee.

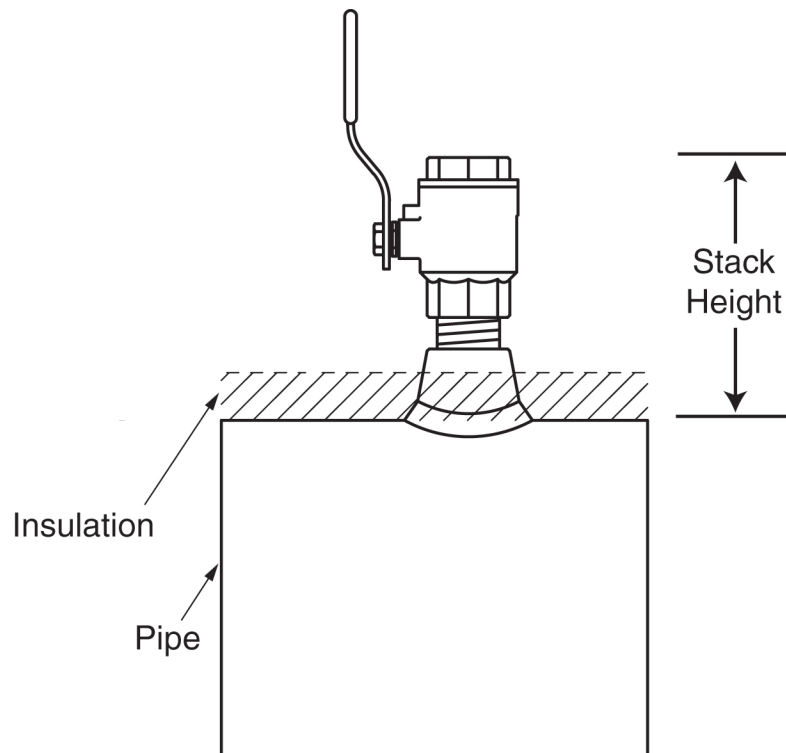

3.2.6 Installing the Flow Meter



WARNING

When you are ready to refill the system, make sure that all lines are filled with water before inserting the meter into the flow stream. If the lines are not filled and this is a hot water system, some water may flash to steam and exceed the high temperature limit for the sensor head assembly. This flash over could also exceed the pressure ratings of the meter and the assembly could fail allowing steam and hot water to escape causing serious injury.

Tools needed for standard installation:

- 1 5/16" wrench or adjustable wrench
- 5/8" wrench or small adjustable wrench
- pipe wrench (to hold valve in place)
- pipe thread sealant

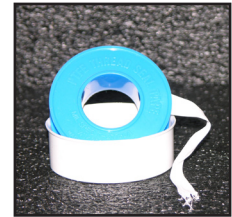

Flush, fill and pressure test the piping system prior to installing the meter. Loosen clamping nut to facilitate installation.

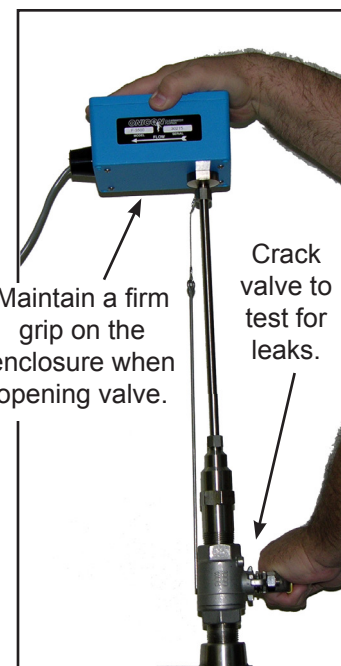
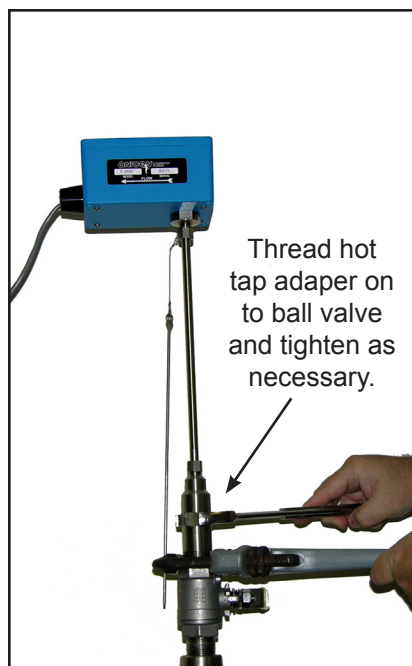
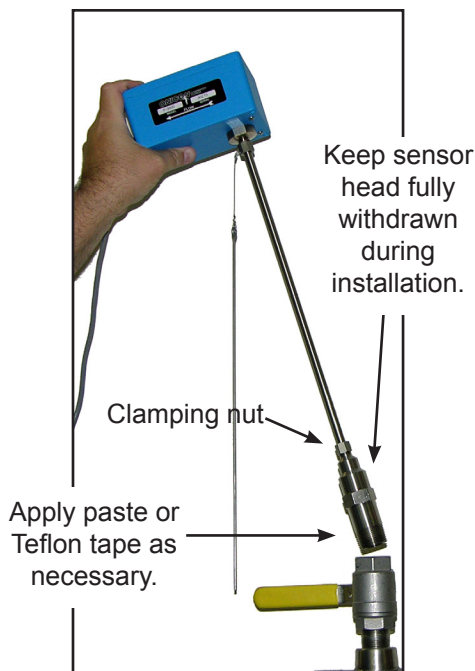

CAUTION



If there are any leaks around the clamping nut or stem, DO NOT ATTEMPT TO STOP THE LEAKAGE BY OVERTIGHTENING THE CLAMPING NUT. Damage to this nut or the clamping ring under the nut may prevent the assembly from properly holding the meter in the pipe. The clamping nut is not part of the sealing mechanism. Any leaks in this area indicate that the "O" ring is not sealing properly and you must contact ONICON for assistance.

3.3 INSERTION OF THE METER



WARNING

SYSTEM MAY BE UNDER HIGH PRESSURE. When adjusting the meter position or removing it, be sure to hold the electronics enclosure firmly by hand before SLOWLY loosening the positioning clamping nut. Failure to do this will allow the pressure to suddenly and rapidly force the meter from the pipe causing serious injury. The meter could also be damaged or break apart causing a break in the water seal with the resultant loss of large amounts of water. The hand effort required to hold the meter will be 0.11 times the pipe pressure.

Begin by calculating the effort that will be required to hold the meter. Establish adequate footing for this task, taking extra caution when working from a ladder or platform. Use the following formula:

$$E = 0.11 \times P \quad \text{Where:} \quad \begin{array}{l} E = \text{effort in pounds} \\ P = \text{system pressure in pounds per square inch} \end{array}$$

Example: In a 300 PSI system, 33 pounds of effort is required to insert the meter into the pipe.

3.3.1 Inserting the Flow Meter

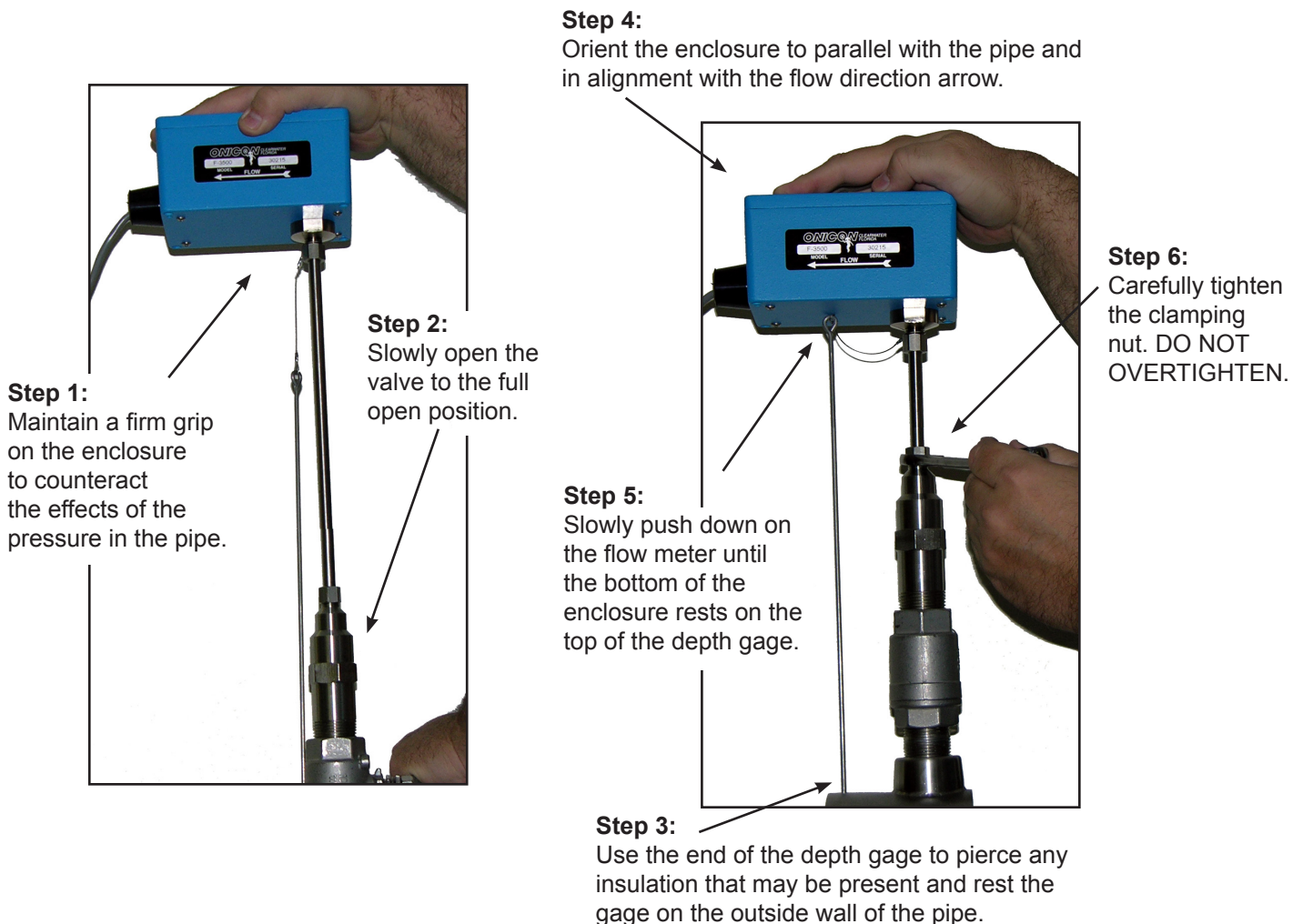

3.4 REMOVAL OF THE METER



WARNING

SYSTEM MAY BE UNDER HIGH PRESSURE. When removing the flow meter, be sure to hold the electronics enclosure firmly by hand before slowly loosening the positioning clamping nut. Failure to do this will allow the pressure in the pipe to suddenly and rapidly force the meter from the pipe causing serious injury. The meter could also be damaged or break apart causing a break in the water seal with the resultant loss of large amounts of water. The hand effort required to hold the meter will be 0.11 times the pipe pressure.



Step 1:
Slowly loosen the position clamping nut while maintaining a firm grip on the enclosure to counteract the effect of pressure in the pipe.



Step 2:
Carefully withdraw the flow meter stem from the pipe until the sensor head is fully inside the hot tap adapter.



Step 3:
After the meter is completely withdrawn, slowly close the valve to isolate flow.



NOTE:
The hot tap adapter will contain a small amount of water.

Step 4:
After the valve is completely closed, unscrew the hot tap adapter from the valve. For hot water meters, partially unscrew the adapter to vent pressure before fully removing the meter.



CAUTION

The main cause of damage to meters comes from accidentally closing the valve on the sensor head. To avoid this, gently rotate the meter by twisting the electronics enclosure back and forth (twist the stem, do not bend it) while you slowly close the valve. If the valve touches any part of the meter, you will feel it as you are twisting the meter. If the valve touches anything, it means the meter is not fully withdrawn. Usually a gentle twisting motion while withdrawing the meter will clear any obstruction and permit the meter to withdraw completely. (Excessive build-up on the stem may require the hot tap “O” ring to be lubricated with silicone.)



WARNING

In hot water systems, even a small amount of water can cause serious personal injury. Use extra caution when working with hot water meters.

3.5 WIRING CONNECTIONS

Make all connections to the attached 10ft cable.

The most common causes of electronic failures are miswired connections during installation. When adding additional cable, record and carefully document any substitution of wire colors. Additional cable may be purchased from ONICON that will allow you to maintain the existing color coding.

All electrical connections to the FB-3500 must be made through the 10ft cable provided with the meter. This cable is not designed to be removed in the field, and any attempt to do so will compromise the weather tight integrity of the enclosure.

The cable provided contains 22 AWG color-coded wires for signal and power and a separate 18 AWG green/yellow earth wire.

Special care is required to ensure that the FB-3500 is connected to earth through the green/yellow earth wire. This connection is required to prevent random electrical noise from interfering with the operation of the meter. (See section 3.5.2 for details.)



CAUTION

Do not attempt to remove the existing cable or to remove the factory installed connection fitting. Doing so will compromise the weather tight integrity of the enclosure and may void the warranty.



CAUTION

Only qualified personnel should attempt to make electrical connections to the FB-3500. Failure to properly connect the FB-3500 power, signal or earth connections may result in damage to the FB-3500 and/or to associated peripheral equipment.

3.5.1 Signal and Power Wiring Connections

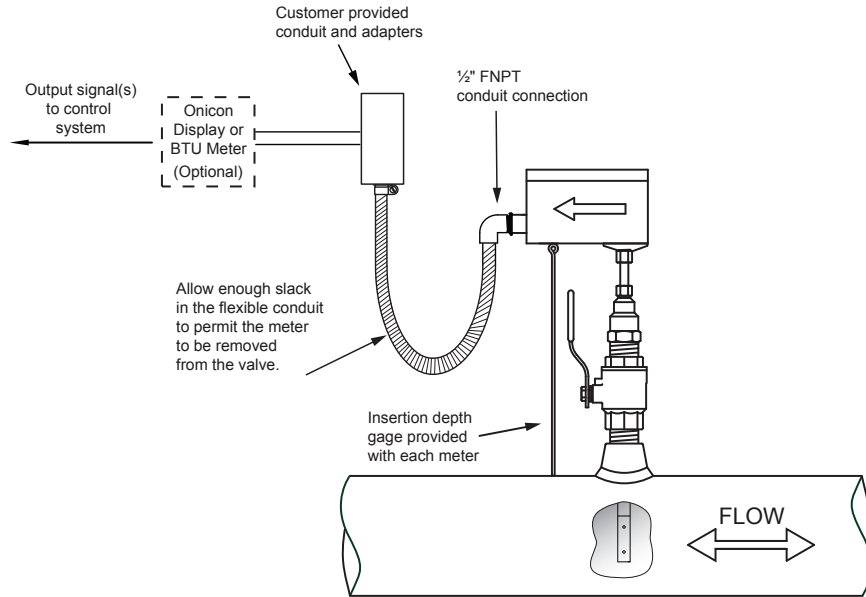

Wire Color	Description	Notes
Red	(+) Supply voltage: 24±4 VDC @ 250 mA or 24±4 VAC, 60 Hz, 6 VAC	Connect to power supply (+): DC (+) or AC (line)
Black	(-) Isolated supply voltage common	Connect to power supply (-): DC (-) or AC (neutral)
Green / Yellow	Earth ground connection	Required to operate the meter
Green	(+) Isolated frequency output	Required when connecting to ONICON display or BTU meter
Yellow	(-) Frequency output common	
Blue	(+) Isolated analog output	Configurable as a 4-20 mA, 0-10 V or 0-5 V output
Brown	(-) Isolated analog output common	
Gray	Forward flow, scaled output, isolated dry contact	Scalable dry contact pulse output for forward flow totalization
Violet		
Gray / Black	Reverse flow, scaled output, isolated dry contact	Scalable dry contact pulse output for reverse flow totalization
Violet / Black		
Orange / Black	Flow direction indicator, isolated dry contact	Contact closed when flow is in direction of arrow on meter
White / Black		
Diagnostic Signals		
Orange	Master alarm, isolated dry contact	Dry contact closure signal indicating fault condition
White		



CAUTION

Failure to provide a proper earth connection to the meter may result in excessive electrical noise that will interfere with the operation of the meter.

3.5.2 Earth Connection

FB-3500 Bi-Directional Electromagnetic Flow Meters are designed to detect microvolt signal levels at the electrodes located on the sensor head. These signals are generated as conductive fluids flow through the magnetic field generated by the meter. If enough random electrical noise is present at the electrodes, it can interfere with the flow measurement. Care must be taken during installation to minimize the effects of electrical noise on the flow meter.

The most effective way to minimize the effects of electrical noise is to make sure that the pipe, the fluid and the flow meter body are all connected to earth ground. This accomplishes two important goals. First, it ensures that the pipe, fluid and flow meter are all at the same electrical potential, and second, it ensures that this electrical potential is the same as earth ground.

In order to be certain that the meter is properly connected to earth, the flow meter earth cable should be run directly to a known earth connection. The length of this earth cable should be as short as practically possible, preferably ≤ 25 feet in length. The table below lists earth connections from best to worst. If necessary, a separate earth cable should be connected to the metal pipe near the meter.



IMPORTANT NOTE

Non-metallic pipes are more susceptible to electrical noise. Grounding rings installed upstream and downstream of the meter location to reduce the electrical noise present in the pipe may be required for proper operation. Refer to section 1.5.1 of this manual for additional information on the use of grounding rings.

Earth Connections (stranded wire 14 – 18 AWG)	
Best	Earth grounding rod driven into the ground
	Earth wire connected directly to the building electrical service panel.
Worst	Earth wire connection inside an electrical outlet near the meter.



IMPORTANT NOTE

Under certain circumstances, connecting the meter to earth through the green/yellow earth wire may increase the amount of electrical noise present at the meter. Contact ONICON for technical assistance if you experience increased noise levels with the earth wire connected to earth.

SECTION 4.0: START-UP & COMMISSIONING FOR ONICON INSERTION ELECTROMAGNETIC FLOW METERS



4.1 HELPFUL HINTS FOR START-UP AND COMMISSIONING

A step-by-step procedure and companion worksheet are located on the next two pages. Please read all installation instructions carefully before proceeding with installation, start-up and commissioning.

1. ONICON flow meters are individually calibrated for a particular application. Be sure to verify the pipe size and location.
2. The electronic flow sensing systems will not work in air.
3. When measuring analog output signals, remember that current (mA) must be measured in series, while voltage is measured in parallel. If the 4-20 mA signal is already connected to a control system, you must break the connection and measure the signal in series.
4. When measuring frequency outputs in Hz, take your multimeter out of “autorange mode” and manually set the range for a voltage level above 15 VDC. This will prevent false readings when signal is not present.
5. All wiring connections should be made at the end of the factory cable. Do not attempt to remove the factory installed cable or change the orientation of the electronics enclosure.
6. Never connect power to analog or frequency output signal wires. ONICON FB-3500 flow meters are not “loop powered” devices.

4.2 START-UP AND COMMISSIONING

Please read the entire procedure before proceeding. A worksheet for checking off the following steps and recording measured values is located on the next page.

1.	Confirm flow meter location. Confirm adequate straight pipe run to achieve desired results.	Is the meter located in the correct location as required by the plans? Compare actual straight pipe upstream and downstream of the meter location to recommended distances identified in this manual. Contact ONICON's technical support department to discuss specifics of your application. If straight pipe run is very short, consult factory PRIOR to installing the meter to discuss possibility of upgrade to an F-3000 series in-line meter.
2.	Confirm pipe size.	Confirm that the meter is tagged for the pipe size in which it is installed. When in doubt, measure the circumference of the pipe. Pipe O.D. = (circumference / 3.14) – (insulation thickness x 2).
3.	Confirm insertion depth and orientation.	Each flow meter comes with an attached insertion gage and instruction tag. Ensure that the meter is inserted to the correct depth and that the electronics enclosure is parallel to the pipe with the arrow in the direction of flow.
4.	Confirm control system programming.	Confirm that the control system input point is properly configured for the analog range (or scale factor) identified on the calibration tag & certificate.
5.	Confirm connection to correct ONICON display or Btu meter (if ordered).	Confirm that the flow meter serial number matches the ONICON display or Btu meter serial number (when ordered together).
6.	Verify wiring before connecting power.	Prior to connecting the power, verify that the wiring is correct as shown in this manual and/or the additional wiring diagram provided with ONICON display or Btu meter. If in doubt, contact ONICON for assistance before proceeding further.
7.	Confirm correct supply voltage.	Verify that 24 (±4) V is available.
8.	Connect power.	Wait approximately 45 seconds after power-on before proceeding further.
The following steps require flow in the pipe. Flow signal readings should be taken while holding the flow rate constant, if possible. Otherwise, take the various output readings as quickly as possible.		
9.	Test flow direction indicator. Confirm that flow direction contact closure output changes state when the flow direction reverses.	Following the steps outlined in sections 3.3.1 of this manual, loosen the clamping nut, rotate the enclosure 180° and confirm that the flow direction contact closure changes state. Return the meter to its correct orientation in the pipe, reset the insertion depth and tighten the clamping nut.
10.	Measure and record frequency output.	The frequency output signal is a 0-15 VDC pulsed output ranging up to 200 Hz and must be measured with a multimeter. Measure DC frequency (Hz) from GREEN (+) to YELLOW (-). Also measure DC volts on same wires. Five to seven is normal for a pulsating output. Zero VDC indicates no output. $\text{GPM} = \frac{\text{frequency in Hz} \times 60}{\text{meter factor in ppg}}$ (Refer to calibration tag for meter factor.)
11.	Measure and record analog or pulse outputs. Current Output: Voltage Output: Scaled Output:	Refer to flow meter wiring diagram for wire colors for the various outputs available, based on your particular flow meter model. Use the following formulas to calculate flow rate from measured analog signals: $\text{GPM} = \frac{(\text{measured current in mA} - 4) \times \text{Full Scale Analog Flow Rate}}{16}$ $\text{GPM} = \frac{\text{measured VDC} \times \text{Full Scale Analog Flow Rate}}{10}$ Each contact closure = unit volume identified as "Scale Factor" (measure and record time interval between contact closures)
12.	Compare various output signals to each other and to the flow rate displayed by the control system.	Compare the flow rates calculated in steps 10 and 11 to each other and to the flow rate indicated by the control system. Refer to troubleshooting guide when readings are inconsistent.
End of standard start-up and commissioning. Please contact ONICON at (727) 447-6140 with any questions.		

4.3 START-UP AND COMMISSIONING WORKSHEET

Please read all installation instructions carefully prior to proceeding with these steps. Use the following worksheet for checking off the commissioning steps and recording measured values. Steps 9 - 12 require flow in the pipe. Flow signal readings should be taken while holding the flow rate constant, if possible. Otherwise, take the various output readings as quickly as possible.

STEP	TEST/MEASUREMENT	S/N: _____	S/N: _____	S/N: _____	S/N: _____
1.	Meter location:				
2.	Confirm pipe size:	_____	_____	_____	_____
3.	Insertion depth and orientation:				
4.	Control system programming:				
5.	Match display or Btu meter serial number (S/N) if ordered:	_____	_____	_____	_____
6.	Signal connections verified:				
7.	Supply voltage verified:	_____	_____	_____	_____
8.	Connect power:				
The following steps require flow in the pipe. Flow signal readings should be taken while holding the flow rate constant if possible. Otherwise, take the various output readings as quickly as possible.					
9.	Flow direction indicator changes state (Y/N)				
10.	Frequency output(s): Avg = green				
	Average frequency (Hz):	_____ Hz	_____ Hz	_____ Hz	_____ Hz
	Average frequency (VDC):	_____ VDC	_____ VDC	_____ VDC	_____ VDC
	Calculated flow rate:	_____ GPM	_____ GPM	_____ GPM	_____ GPM
11.	Analog or pulse output(s)				
	4-20 mA signal:	_____ mA	_____ mA	_____ mA	_____ mA
	0-5 / 0-10 V signal:	_____ VDC	_____ VDC	_____ VDC	_____ VDC
	Scaled output interval:	_____	_____	_____	_____
	Calculated flow rate:	_____ GPM	_____ GPM	_____ GPM	_____ GPM
12.	Flow rate displayed by control system:	_____ GPM	_____ GPM	_____ GPM	_____ GPM

4.4 TROUBLESHOOTING GUIDE

NOTE: Also refer to the START-UP AND COMMISSIONING GUIDE located on page 22.

REPORTED PROBLEM	POSSIBLE SOLUTIONS
No signal	<ul style="list-style-type: none"> • Verify that the meter is properly inserted into the pipe. • Verify that the electronics enclosure is parallel with the pipe. • Verify 24 V supply voltage. • Verify correct wiring to control system (see wiring diagram). • Verify that there is flow in the pipe. • Verify that the meter earth cable is connected to earth. • Check to see if the alarm contact closure output is closed (orange & white wires). A closed contact could indicate either an empty pipe or excessive electrical noise, possibly due to a poor earth ground. • Low conductivity water (≤ 20 μsiemens) may activate the empty pipe detector and/or increase the potential for electrical noise problems.
Reading is too high or low	<ul style="list-style-type: none"> • Verify pipe size. Contact ONICON if pipe size is different from calibration tag. • Verify that the meter is properly inserted into the pipe. • Verify that the electronics enclosure is parallel with the pipe. • Verify correct wiring to control system (see wiring diagram). • Confirm that the output signals are consistent with each other (frequency vs. analog, etc). • Confirm that the control system is programmed for correct flow range or scale factor. • Verify that the meter earth cable is connected to earth. A poor earth connection can lead to excessive noise that can affect the flow reading.
Flow direction indicator does not change state when flow direction changes.	<ul style="list-style-type: none"> • Meter will not switch at very low flow velocities. Confirm that flow velocity exceeds 0.2 ft/sec. • Check for open connections between each contact closure wire (orange / black & white / black) and the control system input.
Analog signal seems high or low and does not correspond to frequency output	<ul style="list-style-type: none"> • Check for ground loop or offset voltage: • Disconnect analog signal input from control system and measure analog output directly from the flow meter. Reconnect signal input to control system and measure the analog signals again. Any difference between these readings indicates a potential ground loop or offset voltage. Please contact ONICON for further assistance.
Control system displays flow rate, but no flow rate is indicated on the local display module or Btu meter	<ul style="list-style-type: none"> • Verify that all wires from the flow meter are connected to the display module or Btu meter. • The frequency output wires (green and yellow) must be connected for any ONICON display or Btu meter.

4.4.1 Earth Connections & Electrical Noise Reduction

Introduction

FB-3500 Electromagnetic Flow Meters are designed to detect microvolt signal levels at the electrodes located on the sensor head. These signals are generated as conductive fluids flow through the magnetic field generated by the meter. If enough random electrical noise is present at the electrodes, it can interfere with the flow signal measurement. Care must be taken during installation to minimize the effects of electrical noise on the flow meter.

Minimizing Electrical Noise

The most effective way to minimize the effects of electrical noise is to make sure that the pipe, the fluid and the flow meter body are all connected to earth ground. This accomplishes two important goals. First, it ensures that the pipe, fluid and flow meter are all at the same electrical potential. Second, it ensures that this electrical potential is the same as earth ground.



IMPORTANT NOTE

Non-metallic pipes are more susceptible to electrical noise. Grounding rings installed upstream and downstream of the meter location to reduce the electrical noise present in the pipe may be required for proper operation. Refer to section 1.5.1 of this manual for additional information on the use of grounding rings.

In order to be certain that the meter is properly connected to earth, the flow meter earth cable should be run directly to a known earth connection. The length of this earth cable should be as short as practically possible, preferably ≤ 25 feet in length. The table below lists earth connections from best to worst. If necessary, a separate earth cable should be connected to the metal pipe near the meter.

Earth Connections (stranded wire 14 - 18 AWG)	
Best	Earth grounding rod driven into the ground to the depth of the water table.
	Earth wire connected directly to the building electrical service panel.
Worst	Earth wire connection inside an electrical outlet near the meter.

Diagnosing Electrical Noise Problems

When diagnosing electrical noise problems, it is important to understand that one of four possible conditions are likely to exist. They are as listed in the table below. In order to minimize the effects of noise, it is helpful to understand which of the following conditions are present.

Earth Connection at Flow Meter	Pipe / Fluid Earth Connection	Expected Noise Level	Possible Remedies
Good earth connection ≤ 25 feet from flow meter	Pipe & fluid are connected to earth	Low	None required
Good earth connection ≤ 25 feet from flow meter	Pipe & fluid are not connected to earth	Moderate	A separate earth connection can be made directly to the metal pipe or to the fluid. Non-metalic pipes may require grounding rings installed upstream and downstream of the meter location.
Poor earth connection	Pipe & fluid are connected to earth	Moderate	Removing the earth connection at the flow meter may reduce the noise level. If this is a long wire run, break the connection where the wire connects to the cable coming out of the flow meter. If noise level is still too high, locate a better earth connection for the flow meter.
Poor earth connection	Pipe & fluid are not connected to earth	High	Locate a better earth connection for the flow meter. If noise level is still too high, locate a better earth connection for the pipe or fluid.

CONDITIONS OF SALE

- 1. ACCEPTANCE:** The following Conditions of Sale apply to all sales of ONICON's products. These provisions shall apply even if ONICON fails to object to provisions appearing on, incorporated by, referenced in, or attached to Buyer's purchase order form. Buyer's acceptance of delivery of ONICON's products constitutes its acceptance of these Conditions of Sale.
- 2. DELIVERY AND TITLE:** All product shipments are F.O.B. shipping point and title passes to the Buyer at the time ONICON delivers the merchandise to the carrier. Risk of loss or damage to the product passes to the Buyer at the time ONICON delivers the product to the carrier. The Buyer immediately upon receipt should inspect all shipments, and should there be any evidence of damage or loss in transit, Buyer must file claims or tracers upon carrier. ONICON will assist in tracing shipments upon request.
- 3. LIMITED WARRANTY:** ONICON warrants that for a period of two (2) years following the date of original shipment of an ONICON product: (i) the product will conform to ONICON's standard written specifications applicable to such product in effect on the date of Buyer's order, or as modified by ONICON's quotation or Buyer's purchase order accepted by ONICON, (ii) the product will be free from defects in workmanship, and (iii) that ONICON has title to the product prior to shipment to the Buyer; provided, however, that the warranties provided herein shall be void and may not apply in the event Buyer misuses or damages a product, including, but not limited to, any use by the Buyer of a product for an application other than one of a type approved by ONICON. ONICON's sole liability and Buyer's sole remedy for any breach of the foregoing warranty is for ONICON to repair or replace, at ONICON's option, any defective product that is returned to ONICON during the warranty period. EXCEPT AS MAY BE SPECIFICALLY AGREED BY ONICON IN WRITING IN RELATION TO EACH SALE, NO OTHER WARRANTIES SHALL APPLY, WHETHER EXPRESSED, IMPLIED OR STATUTORY, AND THERE SHALL BE NO IMPLIED WARRANTIES OF MERCHANTABILITY AND FITNESS FOR A PARTICULAR PURPOSE.
- 4. REMEDIES:** ONICON's OBLIGATION UNDER THE FOREGOING WARRANTIES IS LIMITED SOLELY TO REPAIR OR REPLACEMENT, AT ONICON's OPTION, OF DEFECTIVE OR NONCONFORMING PRODUCTS. ONICON SHALL NOT BE LIABLE FOR CONSEQUENTIAL, INDIRECT, PUNITIVE, INCIDENTAL, OR SPECIAL DAMAGES WHETHER FOUND ON CONTRACT, TORT OR ANY OTHER THEORY OF LAW. No products shall be returned to ONICON without its prior consent and transportation and insurance costs shall be prepaid. Any repair or replacement of ONICON's products under the foregoing warranty will be at no charge to the Buyer provided such repair is done at the ONICON factory or authorized service center. ONICON products that are repaired or replaced under this warranty will be returned to Buyer via the same method of shipment use to return the product to ONICON. Repair or replacement of ONICON products is conditioned upon ONICON's acknowledgement of any alleged defect or nonconformance during the warranty period and issuance of a Return Authorization number. All product returns must reference the Return Authorization number on the outside of the shipping carton and on any paperwork referencing the return.
- 5. PRICES AND PAYMENT TERMS:** The prices set forth in the most recent quote or acknowledgement as applicable, supersede all previous prices or quotations. All quotations are subject to change or withdrawal without notice except as may be specifically noted on the face of the quotation. The prices shown do not include sales, excise or government charges payable by ONICON to Federal, State, or local authority. Any such tax or charge now or hereafter imposed upon the sale or shipment of the products under this contract will be added to the purchase price. Buyer agrees to reimburse ONICON for such tax or charge or provide ONICON with an acceptable exemption certificate. Payment of invoices will be due 30 days from the date of shipment of the products contained therein. In the event that payment of an invoice is not received by the invoice due date, ONICON will assess a late fee not to exceed 1.5% per month or 18% per year, or the maximum allowable by law whichever is lower.
- 6. CANCELLATION:** Buyer may cancel its order, or any part of it, by sending written notice of cancellation to ONICON and paying a reasonable cancellation fee as determined by ONICON. The reasonable cancellation fee will reflect, among other factors, the expenses already incurred and commitments made by ONICON, sales and administrative costs and profit as determined by ONICON. If Buyer received a reduced price based on the quantity of products ordered, but has not purchased the applicable quantity at the time of cancellation, Buyer will pay the price it would have paid had ONICON's sale price been based on the quantity actually purchased.
- 7. CHANGES:** If Buyer makes any changes in its drawings, designs, or specifications applicable in any contract with ONICON that cause an increase or decrease in the cost of performance of the contract, or if such changes result in rework or obsolescence, an equitable adjustment shall be made to the contract. Such changes are subject to ONICON's prior written consent.
- 8. EXCUSABLE DELAY:** ONICON shall under no circumstance be responsible for failure to fill any order or orders when due to: fires, floods, riots, strikes, freight embargoes or transportation delays, shortage of labor, inability to secure fuel, material supplies, or power at current price or on account of shortages thereof, acts of God or of the public enemy, any existing or future laws or acts of the Federal or State Government (including specifically, but not exclusively, and orders, rules or regulations issued by any official or agency of any such government) affecting the conduct of ONICON's business with which ONICON in its judgment and discretion deems it advisable to comply as a legal or patriotic duty, or due to any cause beyond ONICON's reasonable control.
- 9. PATENTS:** ONICON shall defend all suits or proceedings brought against Buyer or its customers arising from claimed infringements of any patent, trademark, service mark or copyright for any product furnished by ONICON and shall indemnify it against all costs, fees, and damages on the condition Buyer promptly notifies ONICON in writing and provides information and assistance to enable ONICON to conduct the defense, provided that ONICON shall have no such obligation in case of infringement resulting from ONICON's conformance to special requirements of Buyer. If ONICON is not able to settle any such suit or proceeding on acceptable terms, ONICON may, at its option, require return of the infringing product and refund the purchase price to Buyer less a reasonable allowance for depreciation or use.
- 10. FAIR LABOR STANDARDS ACT:** ONICON represents that all products delivered under this contract are furnished in accordance with the applicable provisions of the Fair Labor Standards Act as amended.
- 11. APPLICABLE LAW:** This document and any resulting contract shall be governed by and construed in accordance with the laws of the State of Florida. The courts of the State of Florida and the federal courts located in Florida shall have jurisdiction and venue with respect to litigation to this contract. In the event of litigation, the prevailing party shall be entitled to recover attorney's fees and costs from the non-prevailing party, including appellate attorney's fees.
- 12. MODIFICATIONS:** These Conditions of Sale along with the prices, quantities, delivery schedules and other provisions and instructions in applicable quotations by ONICON or Buyer's purchase orders accepted by ONICON shall constitute the entire agreement between ONICON and Buyer pertaining to any resulting contract. They can be modified only in writing.