

Mainline Propeller Meters

Models 101/102

150 psi (10 bar) Working Pressure Magnetic Drive Flanged Tube Type

DESCRIPTION

Model: Sensus 101/102 Propeller Meters are primarily intended for accountability measurement of potable and non-potable cold water with flow in one direction only. Registration accuracy is $100\% \pm 2\%$ of actual thruput within specified normal flow ranges. Because all appropriate parts are sealed for protection, the meters can be used in water containing particulate solids (such as sand), without causing undue wear.

Performance: The design of the Sensus 101/102 propeller Meters permits continuous operation up to the maximum rated flow capacity listed for each size, without affecting long term accuracy or causing undue wear. For accurate measurement, a full flow of water through the meter and stated minimum flow rates are required.

Construction: The meter consists of two basic assemblies— the meter tube body and the meter head assembly. Integral straightening vanes in the meter tube body minimize the swirl upstream of the meter so as to direct the flow evenly to the propeller. The 3" through 12" meter tube bodies are internally and externally protected by a superior fusion-bonded epoxy coating for use in potable water systems. The 14" and larger sizes are protected with an epoxy painted finish. The meter head assembly consists of the propeller, bronze gear box and sealed direct reading register.

Magnetic Drive: Direct magnetic drive eliminates mechanical gearing normally required to operate propeller meter type registers. A ceramic sleeve-type magnet in the propeller assembly drives a follower magnet located in a one piece, all bronze gear box. This gear box is oil filled and factory sealed to provide lubrication and long life to the register drive shaft.

Propeller: The propeller and nut are made of polypropylene and rotate on a ceramic coated stainless steel spindle.

Registers: Sensus Model 101 Propeller Meters come equipped with a sealed direct reading (DR) register with low flow indicator. The Model 102 is equipped with an electronic rate of flow indicator (E-ROFI) register. The E-ROFI register is an hermetically sealed unit that electronically displays and transmits totalization and flow rate data to various Sensus act-pak instrumentation to monitor, control and record volume and rate of flow. Other register options available are the impulse contactor (IC) and high speed pickup (HSP).



6" Model 101 Propeller Meter



Standard Sealed Register

E-ROFI Register

Distributed By

Meter, Valve & Control
 877-566-3837

All registers can be positioned in any of four directions for reading ease. Refer to bulletin E-1116 for HSP and bulletin E-1110 for the E-ROFI register.

Installation: Sensus Propeller Meters can be installed in a horizontal, vertical or inclined position. Valves, fittings or other equipment that might create flow turbulence should be positioned at least 5 pipe diameters upstream of the meter and no less than 3 pipe diameters downstream.

Maintenance: The meter head assembly can be removed, repaired and/or replaced without disturbing the meter tube body in line. A spare meter head assembly can be utilized in the event maintenance is required. Cover plates are also available for maintaining service or flushing of lines when the meter head assembly is removed. Factory testing, repair and meter head assembly exchange programs are available.

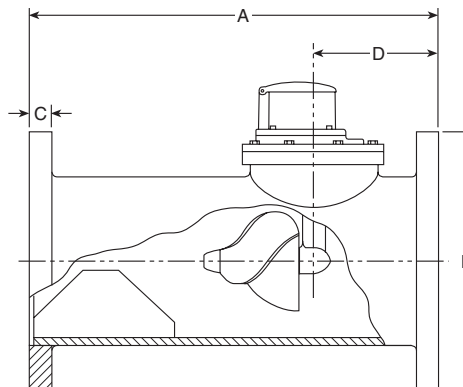
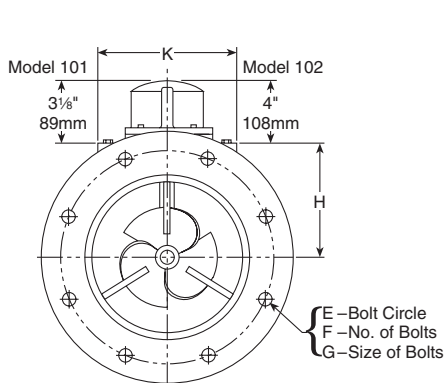

Meter Size	Low Flow GPM m ³ /h 1	Normal Range GPM m ³ /h 2	A in mm	B in mm	C in mm	D in mm	E in mm	F #	G in mm	H in mm	K in mm	Shipping Weight Pounds kg
3" DN 80mm	80 GPM 18.2 m ³ /h	100-250 GPM 23-57 m ³ /h	16" 406mm	7-1/2" 190mm	3/4" 19mm	6-1/2" 165mm	6" 152mm	4	5/8" 16mm	3-3/8" 86mm	5" 127mm	70 lbs. 32 kg
4" DN 100mm	82 18.6	125-500 28-114	18" 457mm	9" 229mm	5/8" 16mm	7-1/2" 190mm	7-1/2" 190mm	8	5/8" 16mm	3-7/8" 99mm	7-1/2" 190mm	85 lbs. 39 kg
6" DN 150mm	160 36.3	220-1200 50-273	22" 559mm	11" 279mm	11/16" 17mm	9" 229mm	9-1/2" 241mm	8	3/4" 19mm	5" 127mm	5" 229mm	115 lbs. 52 kg
8" DN 200mm	190 43.2	250-1650 57-375	24" 610mm	13-1/2" 343mm	11/16" 17mm	9" 229mm	11-3/4" 298mm	8	3/4" 19mm	6" 152mm	9" 229mm	150 lbs. 68 kg
10" DN 250mm	260 59.0	330-2500 75-568	26" 660mm	16" 406mm	11/16" 17mm	10" 254mm	14-1/4" 362mm	12	7/8" 22mm	7-3/8" 187mm	11" 279mm	200 lbs. 91 kg
12" DN 300mm	275 62.4	350-3500 80-795	28" 711mm	19" 483mm	13/16" 21mm	10" 254mm	17" 432mm	12	7/8" 22mm	8-3/8" 213mm	11" 279mm	290 lbs. 132 kg
14" DN 350mm	350 79.5	450-4500 102-1022	42" 1067mm	21" 533mm	1-3/8" 35mm	12" 305mm	18-3/4" 476mm	12	1" 25mm	9-1/4" 235mm	13-1/2" 343mm	450 lbs. 204 kg
16" DN 400mm	450 102.2	550-5500 125-1249	48" 1219mm	23-1/2" 597mm	1-7/16" 37mm	12" 305mm	21-1/4" 504mm	16	1" 25mm	10-1/4" 260mm	13-1/2" 343mm	550 lbs. 249 kg
18" DN 450mm	550 124.9	752-7250 165-1647	54" 1372mm	25" 635mm	1-9/16" 40mm	15" 381mm	22-3/4" 578mm	16	1-1/8" 29mm	11-5/8" 295mm	13-1/2" 343mm	620 lbs. 281 kg
20" DN 500mm	700 159.0	850-9000 193-2044	60" 1524mm	27-1/2" 699mm	1-11/16" 43mm	15" 381mm	25" 635mm	20	1-1/8" 29mm	12-5/8" 321mm	13-1/2" 343mm	820 lbs. 372 kg
24" DN 600mm	1000 227.1	1300-13000 259-2592	72" 1829mm	32" 813mm	1-7/8" 48mm	18" 457mm	29-1/4" 749mm	20	1-1/4" 32mm	12-5/8" 321mm	13-1/2" 343mm	1000 lbs. 454 kg
30" DN 750mm	1600 363.4	2100-18600 477-4224	84" 2123mm	38-3/4" 984mm	2-1/8" 54mm	18" 457mm	36" 914mm	28	1-1/4" 32mm	12-5/8" 321mm	13-1/2" 343mm	1150 lbs. 522 kg
36" DN 900mm	2400 545.0	3000-24000 681-5450	96" 2438mm	46" 1168mm	2-5/8" 67mm	20" 508mm	42-3/4" 1086mm	32	1-1/2" 38mm	12-5/8" 321mm	13-1/2" 343mm	1350 lbs. 613 kg

¹ Low Flow — 95% minimum accuracy ² Intermittent Flow — 25% over maximum rated capacity

SPECIFICATIONS

SERVICE	Measurement of cold water (potable and non-potable) up to 100°F (38°C) with flow in one direction only.
OPERATING RANGE	Continuous Flows: Refer to the chart above Intermittent Flows: 25% over the maximum rated capacity of any given size.
ACCURACY	100% ± 2% of actual thruput
LOW FLOW	Refer to the chart above
MAXIMUM OPERATION PRESSURE	150 psi (10 bar)
FLANGE	3" Size: Round, AWWA 150 Class 4"-12" Sizes: Round, AWWA Class D 14"-36" Sizes: Round, AWWA 150 Class
REGISTER	Hermetically Sealed Direct Reading Register with Low Flow Indicator
METER REGISTRATION	Standard: Six digit, straight reading type with Low Flow Indicator. Full 3" dial face with 100 division increments and a center sweep hand. E-ROFI: Twin six digit, LCD totalizer and rate of flow display. Powered by a "C" size lithium battery factory sealed in an hermetically sealed register. Register replacement is recommended every five (5) years.

MATERIALS—METER TUBE BODY	3" and 4" Size: Ductile Iron 6"-36" Sizes: Fabricated Steel
STRAIGHTENING VANES	Fabricated Steel
COATINGS	3"-12" Sizes: Fusion-Bonded Epoxy 14"-36" Sizes: Epoxy Paint
METER HEAD	Ductile Iron
PROPELLER AND NUT	Polypropylene
PROPELLER SPINDLE	Ceramic Coated Stainless Steel
GEAR HOUSING	One Piece Cast Bronze
TRIM	Stainless Steel
MAGNETS	Ceramic

AUTHORIZED SENSUS DISTRIBUTOR



P.O. Box 487 | 450 North Gallatin Avenue
Uniontown, PA 15401 USA
T: 1-800-638-3748
F: 1-800-888-2403
www.sensus.com/water
h2oinfo@sensus.com

| sales@mvandc.com | Phone: 877.566.3837 | Fax: 925.407.2903