

evoQ₄ Installation & Operation Manual



Table of Contents

Operation.....	3
Application.....	5
Construction.....	6
Handling	6
Installation	7
Environment.....	7
Precautions on piping installation	8
Accessories.....	12
Remote Display and MX35-2 remote display module.....	12
MX39 output modules: Pulse, Elster Encoder, Sensus Encoder	14
Maintenance	15
Troubleshooting.....	16
Disposal	17
Variant particular notes.....	17
Alternate Length (AL) meters.....	17
Replaceable Battery (RB) meters.....	18
Replacement Procedure.....	19
Fire Service Meter (FSM).....	29
Output Modules.....	29

References

evoQ₄ specification sheet

evoQ₄ Alternate Length (AL) specification sheet

evoQ₄ Fire Service Meter (FSM) specification sheet

evoQ₄ Replaceable Battery (RB) specification sheet

TD520-81 Connecting evoQ₄ Output module to Bare Wire Endpoints

Operation

The evoQ₄ is a battery powered magnetic water meter that operates without the use of mechanical measuring elements. Remnant magnetic elements produce the characteristic field within the flow tube while minimizing power requirements. Conductive water moving through the reduced bore flow tube induces a voltage proportional to the rate of flow of the water. The meter senses the voltage via stainless steel electrodes located along the flow tube's sides. The meter's electronics calculate the resulting instant and totalized flow and display the results in standard engineering units on the meter's LCD display. Output options are available per specification.

The LCD display is factory selectable among common units of registration in North America: US Gallons, Cubic Feet, and Cubic Meters. This feature is not accessible in the field. See the diagrams below for a description of the register face icons and details on reading each meter.

Display options for Standard, Replaceable Battery, and Fire Service Meter versions:



1. Flashing battery icon – Low battery indicator
2. Solid battery icon – Stopped measurement low battery indicator
3. Flashing water drop icon - Empty pipe / not measuring indicator
4. Rate of flow indicator
5. Totalization + test digits

1. The low battery indicator should not be present on installation. Do not install a meter with a lit battery icon. The meter has an expected life of 10 years when installed in conditions where average annual temperature is below 86°F (30°C). Average temperature is the combined average throughout the year, not simply the daily high temperatures. See the environmental installation notes below. The icon will begin flashing when the meter has approximately 3 months of working life remaining. The meter will continue to operate normally during this time. For meters fitted with an MX39 pulse module, channel 3 engages to indicate the low battery alarm condition.

2. The solid battery icon (not flashing) indicates that meter has entered a stopped measurement condition. There is not enough battery power remaining for the meter to operate normally. The measurement functions cease. However, the meter does have enough battery power to continue displaying the last good value of totalization. Additionally, the flow rate indicator (4) instead displays a running count of days since the meter stopped measuring. For meters fitted with an MX39 pulse module, channel 3 engages to indicate the battery alarm condition. The meter will typically remain in this state for up to 9 months. At the end of this period, the display goes blank.

3. The flashing water drop icon appears in a number of conditions. The most common is when the meter is not installed or installed with no water in the pipe. If there is no conductive path between the electrodes in the flow tube, the icon appears and no measurement occurs. See the troubleshooting section for more details.

4. The flow rate indicator located in the lower left corner of the register display shows the current instantaneous rate of flow through the meter in US gallons per minute (gpm). For M3 displays, the flow rate is given in cubic meters per hour (M3/h). In reverse flow conditions, a minus sign (-) appears to the left of the flow rate. The rate indicator is meant for reference only. It may appear to fluctuate more than the underlying flow through the system. Again note that the meter is primarily designed for accurate totalization for utility billing purposes; the flow rate indication feature is for reference.

5. Totalization. The top right corner gives the multiplier and unit of registration of the right most digit on the top row. This configuration represents the most common billable units in use by North American utilities. Follow on digits are given in the lower right hand corner. These digits are generally used for testing when visually reading the meter register.

When fitted with an encoder module that reports 6 digits, the value is the top row of digits.

This translates to a resolution of:

1000 USG, 100 CuFt, or 1 M3.

When fitted with an encoder module that reports 8 digits, the value is the top row plus the next 2 digits from the lower right set of digits. In other words, an 8 digit encoder outputs a resolution of: 10 USG, 1 CuFt, or 0.01 M3 (10 liters).

Note for Alternate Length (AL) version meters

1.5" x 13" AL

2" x 15 1/4" AL1

2" x 17" AL2

2" x 10" AL3

AL version meters include 7 top row digits, the associated multiplier in the upper right corner and the value of the 7th digit is:



The 3 lower right digits are the follow on digits. The image shows a reading of 37,041.47 CuFt.

The meter serial number is etched into the stainless steel ring at the 6 o'clock position of the register.

X 100 USG; X 10 CuFt; X 1 M3

Application

The evoQ₄ is an electromagnetic water meter designed to provide consistent and accurate measurement in both high and low flow-rate environments. With a flow tube unrestricted by mechanical elements, a 10 year battery life and an innovative flange design, the evoQ₄ is ideal for a wide variety of bulk water metering applications, such as network management, leakage monitoring, and commercial billing. The meter is designed for use with potable cold water systems up to 120°F. The water must be conductive with a minimum conductivity value of 50 µS/cm.

Typical applications include utility commercial account billing, distribution system monitoring, and approval for use in lieu of AWWA C703 mechanical fire service assemblies. The specification sheets for the individual variants provide accuracy performance data. The meter is optimized to measure potable water for customer service billing in utility applications, the meter should not be used in non-potable water applications where foreign substances such as sand, stones, and debris could coat the electrodes or damage the flow tube lining. In particular, fats, oils and grease must be avoided. In the event such contaminants do coat the electrodes, periodic maintenance to remove the coating may be required.

The available configurations of meters are listed here:

1.5 – 2" evoQ ₄ Alternate Length (AL)	Mid-size customer service billing
2" – 12" Standard	Utility commercial account billing, distribution system monitoring
2" – 12" Replaceable Battery (RB)	Utility commercial account billing, distribution system monitoring
3" – 8" Fire Service Meter (FSM)	Combined fire and potable water service measurement

The following chart describes the expected pressure loss through the meter by size.

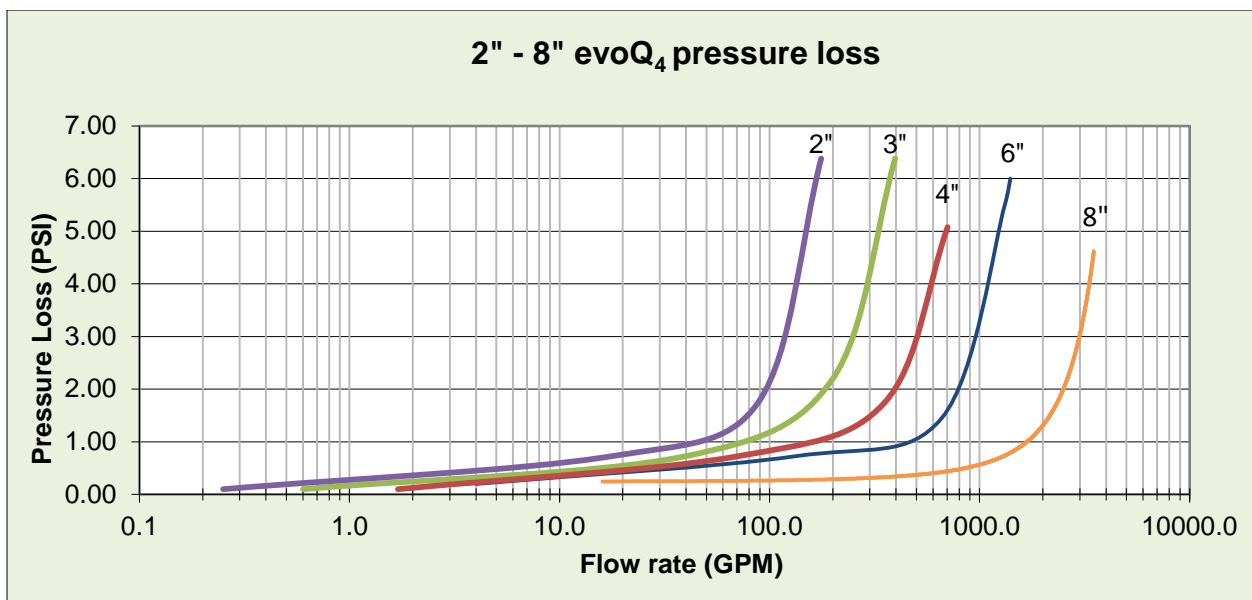

Construction

The meter consists of a 316 stainless steel flow tube, 316 stainless steel joint pipes to extend lay length to AWWA turbine (or alternate) lay lengths, epoxy coated ductile iron flanges, a 304 stainless steel outer case, tempered glass lens sealed LCD display, impact resistant polymer register cover and lid. Lithium batteries power the meter system throughout its lifecycle. Replaceable battery packs (for RB version meters) are further encased and housed in a polymer outer cover.

Handling

The products in the evoQ₄ line incorporate lithium batteries exceeding 2 grams, prompting special transportation guidelines, i.e. "Regulation of Dangerous Goods, UN3091". Take care to observe local, state, national, and international regulations regarding transportation of lithium containing electronic devices.

Upon receipt of product packages, check the appearance and contents to determine if any damage occurred in transit and that correct configuration of product and accessories arrived. Replaceable battery packs may ship in separate packages from their meters.

When storing products prior to installation work, place packages in a well-ventilated area out of direct sunlight, and away from rain and other weather elements. Do not store with combustibles, inflammable substances or heating elements near the products. Storage temperatures for all evoQ₄ products:

+14°F to +122°F (-10C to 50C)

Hold the product by the outer case.

Do not drop the product or apply sudden force (shock) to it.

Do not hold the product by the register or register neck; deformation of the neck may damage the meter.

Do not hold the product by the flange or joint pipe.

Do not hold the product by accessory cables; the accessory may be damaged, or the product may fall.

Do not support the product via wire or rod passed through the flow tube; damage to the electrodes or lining may occur.

Failure to follow handling instructions will void product warranty.

Installation

Environment

Do not install the product in an area affected by strong electromagnetic field. Select a location 3-6 feet or more away from the following: power line, transformer, electric pump, or motor. Do not install the product at a point immediately below high voltage transmission lines, in the vicinity of other electromagnetic flow meters, or near other equipment that generates a significant magnetic field (such as electrified rails).

Do not install the product in a place where stray electrical current is flowing. Electrolytic corrosion protection current or leakage current from a submersible pump flowing through the metered water can affect accuracy or product operation. If such current is observed, apply grounding mechanisms to isolate the current from the product.

Do not install the product in an area that is out of the specified range of ambient temperature. Such installation may affect battery life or product operation.

Working ambient temperature: +14°F to +122°F (-10°C to +50°C)

Storage ambient temperature: +14°F to +122°F (-10°C to +50°C)

Fluid temperature: +32°F to +122°F (0°C to +50°C)[+86°F (+30°C) for optimal battery life]

* Freezing must be avoided.

Water ingress protection rating: IP68, continuously submersible to 1m.

Avoid installation in direct sunlight that might cause temperatures to exceed the ambient temperature specification. Use of a sun shade is recommended. Keep the lid closed to protect the LCD display except when reading the display.

Install the remote display indoors or in an enclosure protected from direct sun, wind, and precipitation.

Avoid high temperature environments (above 86°F / 30C average annual temperature). Sustained high temperatures may affect battery life.

Do not install the product in locations subject to corrosive agents such as seawater, brackish water, bleach (or other sources of chlorine), hydrogen sulfide, etc. For unknown soil conditions, consider use of a sacrificial anode kit. Elster part number BQA6899. Exposure to strong corrosives may invalidate warranty protection.

Do not install the product in a location subjected to continuous vibration.

Observe the provision for submergence depth when installing in flooded chambers.

If installing in a direct bury environment, ensure there is adequate protection from weight applied to the ground surface above.

Observe specified pressure rating limits:

1.5" – 2" AL	150 PSI
2" – 8" Standard and RB	230 PSI
10" – 12" Standard and RB	150 PSI
3" – 8" FSM	175 PSI

The meter must be installed with the direction of flow indicated by the arrow badge on meter body. The meter may be installed in horizontal, vertical, or inclined lines; however the meter must be installed such that a full pipe of water passes through the meter at all times. In order to meet specified accuracy levels, the meter should be installed such that 5 pipe diameters of straight pipe the same size of the meter upstream and 3 pipe diameters the same size as the meter downstream prevent turbulent jetting. Use of flow straightening devices reduces this requirement. See installation precautions later in this document.

The meter must be installed mating the meter flange with a companion flange of the same type; i.e. 2" meters with 2 bolt oval flanges must be mated with 2" oval companion flanges, etc. Meters must be installed with the supplied full face gasket to prevent leakage.

The meter end connection includes the lip of the flow tube extension which serves to equalize the electrical potential of the fluid, the surrounding piping, and the meter. No additional grounding rings, straps, or other devices are required in most conditions. In rare installation environments with stray electrical activity conducted through piping, take care to electrically isolate the meter from such conditions.

When tightening the flange connection, be sure to tighten in a balanced fashion so that the companion flange face and the tube extension meet flush around the entire face. Do not over tighten the flange bolts. A torque value between 60 and 65 lb*ft (81 – 88 Nm) is recommended.

For installation of outputs or remote display, see the section below: Outputs.

Failure to follow Environmental installation instructions will void product warranty.

Precautions on piping installation

Please observe these cautions on piping arrangements and installation techniques:

Clean pipes and flanges before installation to avoid contact with fats, oils, and grease or other contaminants.

Do not mount the meter with its display surface facing downwards.

Avoid locations with pulsating flow. Some patterns of pulsating flow may affect accuracy performance.

Provide clearance (13.75 inches or more between pipe edge and floor) for turning a box wrench, particularly under a meter pipe section which has lower side bolts and nuts that are difficult to tighten.

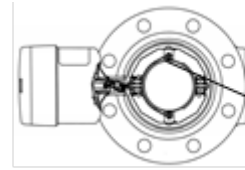
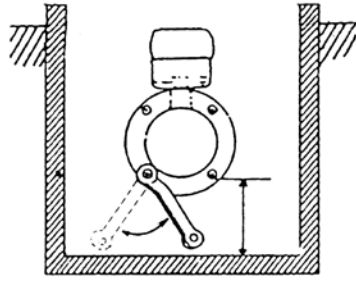

✘ Bad example

Electrode

Pipes, especially newly installed ones, often have foreign matter (such as oil) on the inside. Be sure to clean the pipe before installing the electromagnetic meter. For optimum meter performance, follow the precautions given below.

Install the meter where it can be easily accessed for maintenance purposes.

There are no restrictions regarding pipe orientation where the meter is installed (horizontal, vertical, inclined) except the display surface should not be facing downwards. Avoid installation orientations with the electrodes at the top of the piping arrangement. Air in the pipe uncovering the electrode from contact with water may cause measurement error.

Make sure that the meter pipe center is not displaced and the display is not askew. Fit the gaskets in between the pipe ends and the meter. After you check the displacement of the meter pipe center, tighten the nuts diagonally in the order shown by the arrows in the figure above. Tighten the nuts to squeeze the gaskets until fully sealed.

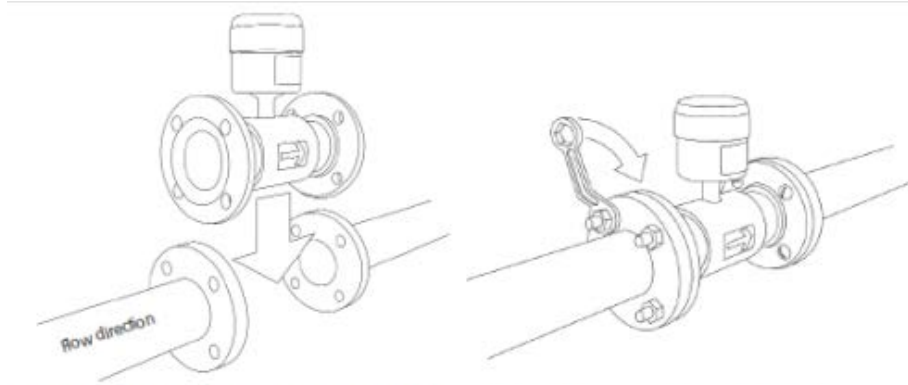

1) Place the meter between the piping flanges, set in the desired position, taking care not to damage it.

2) Fit the gaskets in between the pipe ends and the meter. Insert bolts, attach nuts, and tighten slightly. Make sure meter centerline aligns with the pipe and the display is not askew.

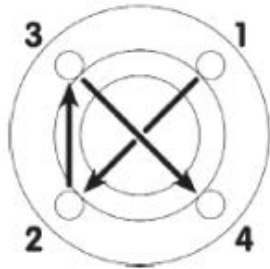

3) Check meter centerline again, and then tighten the nuts diagonally in the order shown in the figure above. Tighten the nuts to squeeze the gasket until fully sealed.

CAUTION: Make sure not to step on the display unit of the electromagnetic meter at any time. Pay particular attention while you are doing the pipework. Never try to adjust the meter position using the display unit for grip after tightening the bolts. Do not attempt to correct problems by hitting the meter body.

Arrange the meter installation location within the pipework observing the following notes:
 Non ideal piping arrangements may cause variation from stated accuracy performance specifications in extreme cases.

(D: Pipe nominal diameter)

- For accurate measurement, pipe must always be filled completely with the flowing fluid.

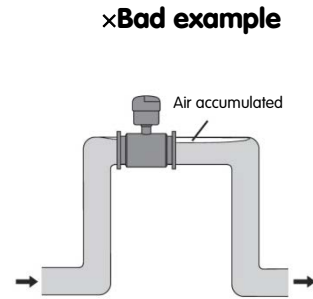
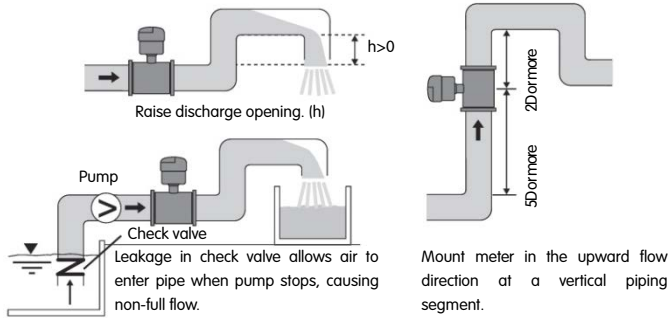

- No air must be sucked in.

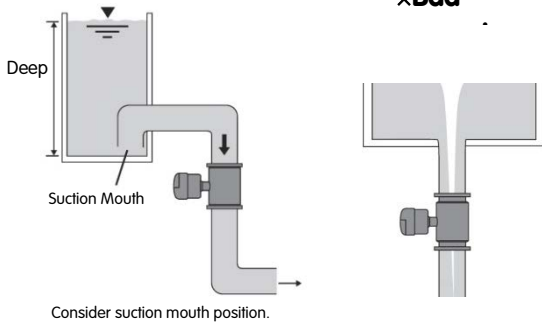

- No solid substances must precipitate.

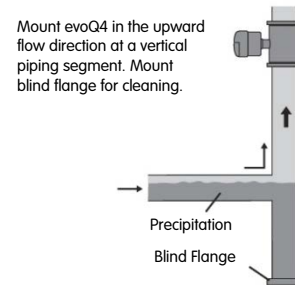

- Straight section of pipe must be provided.

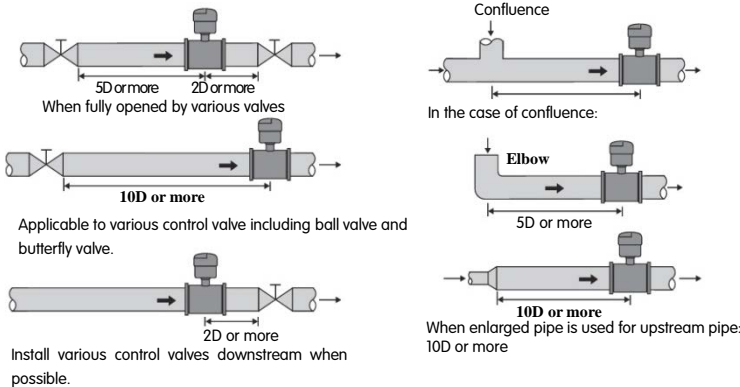

- Fluid (chlorine etc.) of different water quality must be mixed downstream of the meter.

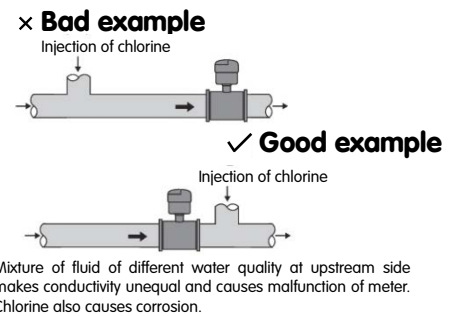

× Bad example

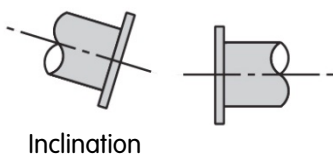

× Bad example

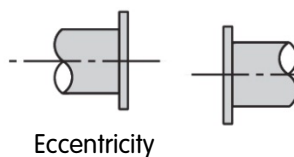

✓ Good example

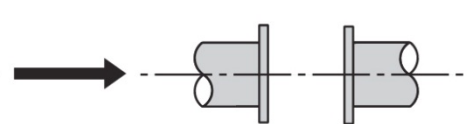

Accessories

Remote Display and MX35-2 remote display module

Perform wiring work with clean, dry hands.

Do not allow cable ends to become wet.

Use of crimping terminals on the remote display module cable ends is recommended.

Securely attach remote display module wires to the remote display. Be careful to avoid short circuit of the braided wire and terminals. After completing the wiring, lightly pull on the cable to check the wiring connection.

Pass cables through steel conduit away from equipment generating strong magnetic fields. Avoid running cable near power lines, particularly parallel to power lines. When laying cable underground, use conduit.

Do not pull on the cable or allow heavy material to crush, cut, or pinch the cable.

Use an appropriate waterproof splicing kit when splicing additional wire. Contact Elster AMCO Water customer service to order field splice kits. Follow splice instructions.

Follow these steps for mounting the remote display module onto the meter:

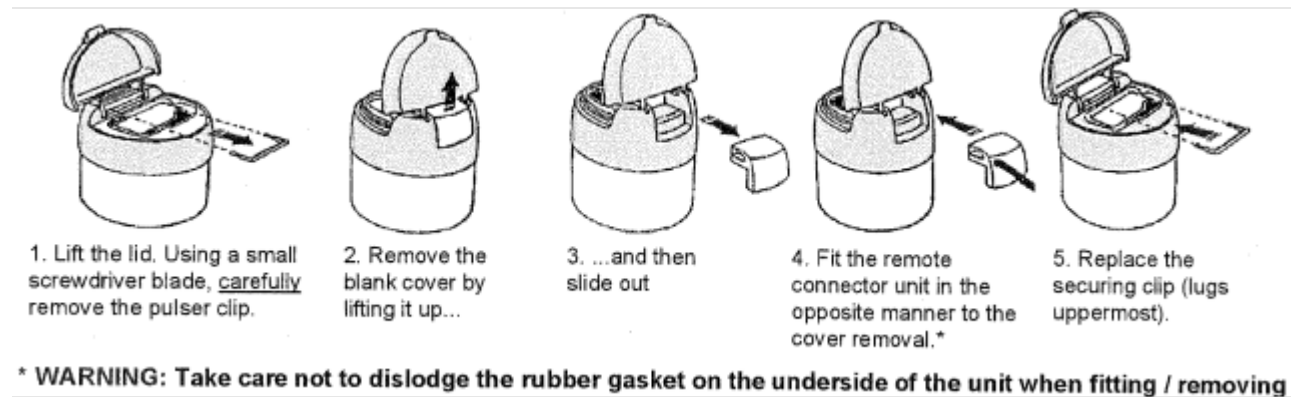

- Check optical communication protective gasket
Prior to work, check that an optical communication protective gasket is mounted on MX35-2.

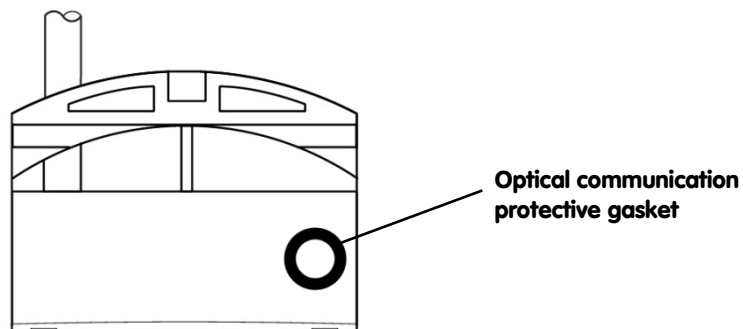

Do not hold the center of the retaining clip when inserting or removing it. Hold both ends and slowly insert or remove it. Ensure that the lugs on the clip ends are pointed upward.

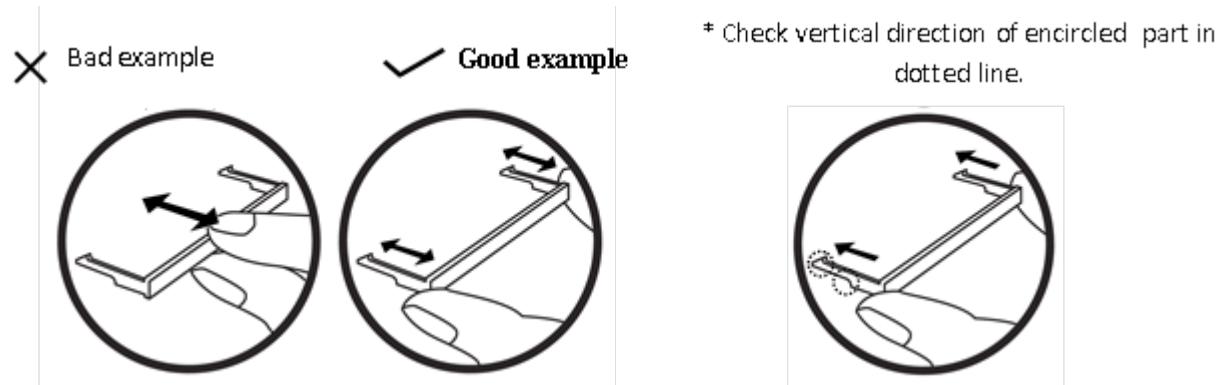

Ensure the optical port is not blocked by foreign substances.

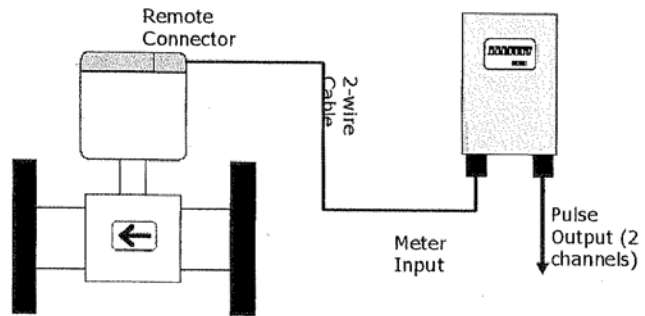
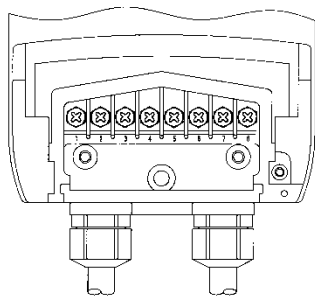

Wiring & Connection Details								
Number	1	2	3	4	5	6	7	8
Colour of wire	White	Black						
Mark	+	-	+	- (Common)	+			
Description	Meter Input	Pulse Output 1	Pulse Output 2	NC				

Left upper Fig.: Terminal Block
Left lower Fig.: Connection cross-reference

Right upper Fig.: Connection diagram

Do not use terminals 7 & 8.

Close the terminal cover firmly when wiring is complete.

Further enclose the remote display in a weatherproof enclosure if mounted outdoors.

Environmental rating: IP63

Working ambient temperature: +14°F to +122°F (-10°C to +50°C)

MX39 output modules: Pulse, Elster Encoder, Sensus Encoder

Perform wiring work with clean, dry hands.

Do not allow cable ends to become wet.

Use an appropriate waterproof splicing kit when splicing additional wire or Automatic Reading System / Automated Metering Infrastructure (AMR/AMI) endpoints. Contact Elster AMCO Water customer service to order field splice kits. Follow splice instructions.

Securely attach MX39 module wires to the follow on device. Be careful to avoid short circuit of the braided wire and terminals. After completing the wiring, lightly pull on the cable to check the wiring connection.

Pass cables through steel conduit away from equipment generating strong magnetic fields. Avoid running cable near power lines, particularly parallel to power lines. When laying cable underground, use conduit.

Do not pull on the cable or allow heavy material to crush, cut, or pinch the cable.

Follow these steps for mounting the output module onto the meter:

- Mounting method of MX39 onto evoQ₄

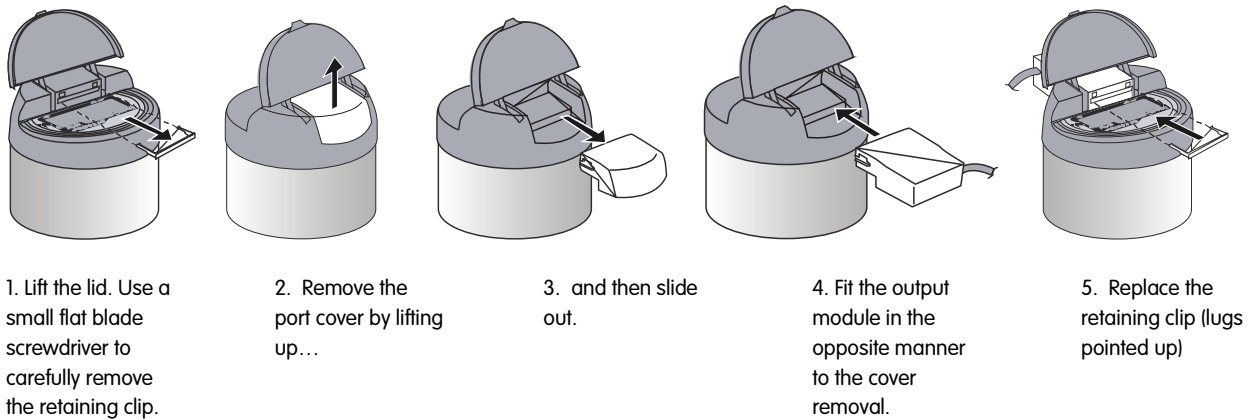

- Check optical communication protective gasket

Prior to work, check that an optical communication protective gasket is mounted on MX39.

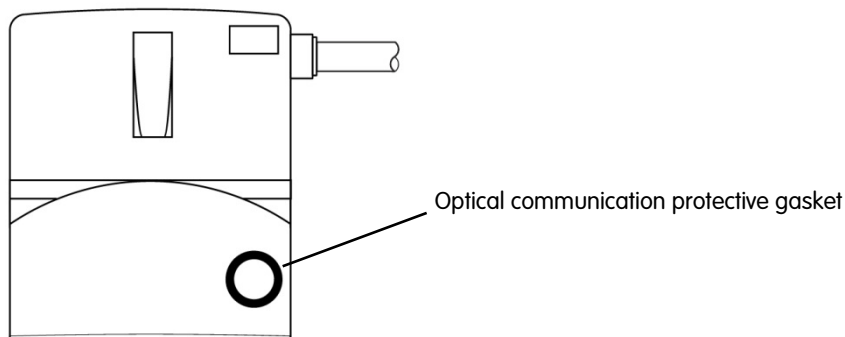

Do not hold the center of the retaining clip when inserting or removing it. Hold both ends and slowly insert or remove it. Ensure that the lugs on the clip ends are pointed upward.

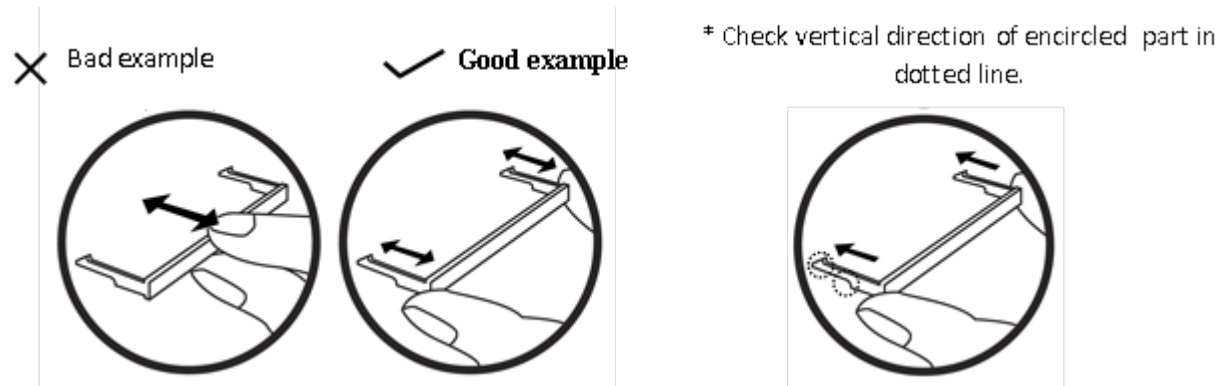

Ensure the optical port is not blocked by foreign substances.

Maintenance

Clean the inside surface of the measuring pipe with a soft cloth or soft bristle brush. Do not use a metallic brush.

If contaminant debris is affixed to the flow tube, use a neutral detergent to scrub the surface clean.

Do not attempt to repair the product. The product is not field service repairable. Handle the product with sufficient care to avoid damage. If damage does occur or product becomes inoperative prior to end of expected life, contact Elster AMCO Water technical support.

Troubleshooting

In the event the meter does not appear to be operating to expectation, please review the list of field observed conditions and check for likely causes.

Observed condition	Possible fault	Remedy
Battery icon flashing	Battery power is near end of life	Replace meter For RB meters – replace battery pack
Battery icon steady	Battery power is depleted for operation	Replace meter For RB meters – replace battery pack
Display is blank	Physical damage: Broken register lens Bent or crushed register neck Dented or penetrated body	Evaluate installation and handling conditions. Take steps to protect meter from damage. Replace meter.
	No power	Check age of meter. If near anticipated battery life, replace meter or battery pack. If < 5 years contact Tech support
Broken flange	Incorrect piping arrangement or flange mating techniques	Follow installation instructions
Leakage at flange	Incorrect piping arrangement or flange mating techniques	Follow installation instructions Contact Tech support
Total increments (up or down) when not installed	Check for physical damage as above	Evaluate installation and handling conditions. Take steps to protect meter from damage. Replace meter.
	No external sign of damage.	Contact Tech support
Total increments in wrong direction	Meter installed with forward arrow in wrong direction	Reinstall the meter in correct orientation.
Water drop icon present	No water or insufficient water in flow tube	Ensure meter is installed with full pipe of water according to installation instructions. Ensure bypass valve is opened.
	Nonconductive water	Check the conductivity of the water being measured. Conductivity < 50 μ S/cm is not recommended for the meter
	Covered electrodes	Uninstall the meter and check electrodes for mineral deposits (Calcium carbonate, etc.) or coating from fats, oils, grease, or other nonconductive material. Follow maintenance procedures.

Observed condition	Possible fault	Remedy
Flow rate indicator is erratic	Low signal to noise ratio	Check water conductivity. Check for stray voltage sources. Consider resizing to smaller meter.
	Pulsating flow	Observe recommended installation conditions.
Automatic reading system error or incorrect read	Incorrect output module	Ensure proper match between output module type, pulse weight, protocol, etc. and AMR solution specifications. Contact Tech support Contact AMR provider support
	Incorrect module attachment	Observe installation instructions for evoQ ₄ output accessories. Check for obstruction of the meter optical port to output optical port.
	Output module power	Check installation date / expected life of output module. Replace as necessary.
	Incorrect module / endpoint connection	Follow wiring instructions for particular endpoint. Contact Tech support
	Pulse count / reading mismatch	Program endpoint with correct initial read. Check module pulse weight with endpoint expected pulse value. Contact Tech support

Disposal

Do not cut, disassemble, transform, heat, or burn when disposing of the products. Follow local, state, and federal regulations for disposal and handling of lithium containing electronic devices. Take special care to avoid damage to the batteries when disposing of the products to avoid ignition or explosion.

Variant particular notes

Alternate Length (AL) meters

Be sure to specify lay length needed when ordering evoQ₄ (AL)

Available options:

1.5" X 13"

2" x 10" AL3

2" x 15 ¼" AL1

2" x 17" AL2

Replaceable Battery (RB) meters

evoQ₄ RB is designed to allow flexibility for powering the evoQ₄ meter system. The replaceable battery pack is a common design that attaches to all RB meters from sizes 2" through 12". The pack contains 3 Lithium battery cells and yields the following anticipated operating life when attached to a particular size of meter:

2", 3", 4"	10 years
6"	7 years
8", 10", 12"	5 years

The battery packs of evoQ₄ RB are shipped separate from the meter package. This facilitates storage and stocking of meters to ensure customers receive the longest possible life from the battery / meter system. Instructions for attaching the battery pack at initial startup and removal for replacement when battery pack life is complete are included below.

Battery pack replacement must be undertaken by competent, appropriately trained and authorized personnel. Elster Metering and Elster AMCO Water, LLC may develop a certification program to train such authorized personnel, including Distributors and / or utility maintenance staff as appropriate. Installation by untrained personnel or failure to follow the instructions may result in damage to the meter or battery pack that is not covered by warranty.

The battery pack must be handled with care because the battery pack has lithium thionyl chloride batteries.

Store RB without opening a sealed moisture-proof bag in a cool (preferably below 30°C (86°F)) and ventilated area, away from moisture, combustible/flammable materials, source of heat, open flames, food and drink.

Under normal conditions of use, the electrode materials and liquid electrolyte they contain are not exposed to the outside, provided the battery integrity is maintained and seals remain intact. Risk of exposure is highest in case of abuse (mechanical, thermal, electrical) which leads to the rupture of the battery container. Electrolyte leakage, electrode materials reaction with moisture/water or battery venting, explosion, or fire may occur, depending upon the circumstances.

- **Accidental Release Measures**

In the event mishandling leads to a battery pack rupture, remove personnel from area until fumes dissipate. Do not breathe vapors or touch liquid with bare hands.

If the skin has come into contact with the electrolyte, it should be washed thoroughly with water. Sand or earth should be used to absorb any spilled material. Seal leaking battery and contaminated absorbent material in plastic bag and dispose of as hazardous material in accordance with local regulations.

- Warning:
Risk of fire, explosion and severe burn hazard.

Do not crush, recharge, disassemble, heat above 60°C (140°F) or incinerate.

Do not pierce. Exposure to the chemicals contained within could be harmful.

Do not short-circuit.

The exhausted battery pack should be disposed of in accordance with local hazardous material regulations.

Dispose of all depleted battery packs promptly.



Store batteries in non-conductive (i.e. plastic) trays.

Keep away from children.

Replacement Procedure

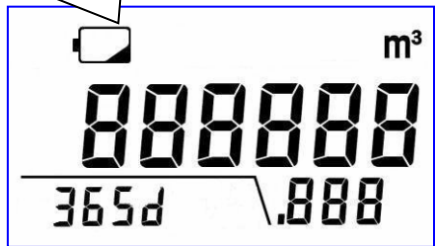
To replace the battery pack ensure that the environment is clean and dry, then proceed as follows

<div style="border: 1px solid black; padding: 5px;"> <p>Low battery alarm indicator</p>  </div>	<p>[Step 1]</p> <p>1. Check the estimated battery life according to the month and year of manufacture printed on the side or the bottom of the battery pack.</p> <table border="1" data-bbox="938 1083 1414 1268"> <thead> <tr> <th>Meter Size (inch)</th> <th>Estimated Battery Life (year)</th> </tr> </thead> <tbody> <tr> <td>2", 3", 4"</td> <td>10</td> </tr> <tr> <td>6"</td> <td>7</td> </tr> <tr> <td>8", 10", 12"</td> <td>5</td> </tr> </tbody> </table> <p>2. Replace the battery pack immediately when the "Low battery alarm indicator" blinks.</p>	Meter Size (inch)	Estimated Battery Life (year)	2", 3", 4"	10	6"	7	8", 10", 12"	5
Meter Size (inch)	Estimated Battery Life (year)								
2", 3", 4"	10								
6"	7								
8", 10", 12"	5								

<p>Battery Pack</p> 	<p>[Step 2]</p> <p>The following materials are required in preparation for replacement of the battery pack.</p> <ul style="list-style-type: none"> - New Battery pack* - Diagonal wire cutter - Special screwdriver (Size: Tamperproof Torx- T10) - Wet tissue paper - Cotton swap - Clean, dry cloth <p>* <u>Do not open the Moisture proof bag till just before battery replacement.</u></p>
	<p>[Step 3]</p> <ol style="list-style-type: none"> 1. Open the lid of the meter display. 2. If there are any adherents (e.g. dirt, mud) to the battery pack, wash them away from the battery pack with water. * Remove bits of grime from the battery pack with the wet tissue. 3. Use the dry cloth to completely wipe away the water / moisture that remains on the battery pack
	<p>[Step 4]</p> <p>Remove the Protective Sheets from the Torx securing screws.</p>

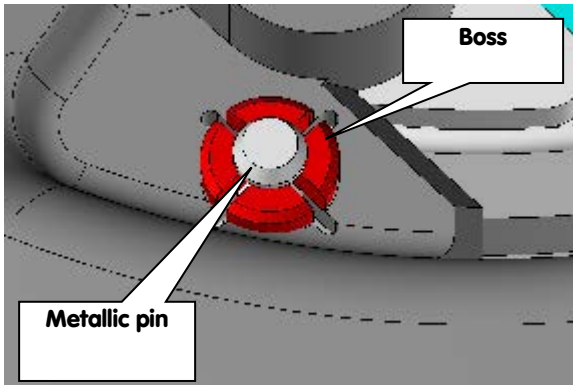

Before cutting out the boss



After cutting out the boss



[Step 5]

1. Cut out the boss that surrounds the metallic pin with the diagonal wire cutter.

* Use caution not to cut out the metallic pin.

2. Do not remove the battery pack without cutting out the boss.

* If the battery pack is removed forcibly, the meter and the battery pack may be damaged.

**[Step 6]**

1. Loosen the torx-screws with the special screwdriver.
Slide the battery pack up and detach it from the meter .
2. Low battery alarm indicator lights when the battery pack is detached, then the LCD will turn off and all measurement will be stopped in 1-2 minutes.
3. The accumulated volume just before the stopped measurement will be stored in the nonvolatile memory.
* Write down the accumulated volume just before stopping the measurement so that operation can be confirmed after battery pack replacement.
* After battery pack replacement, the meter will restart the measurement from the accumulated volume held in memory.

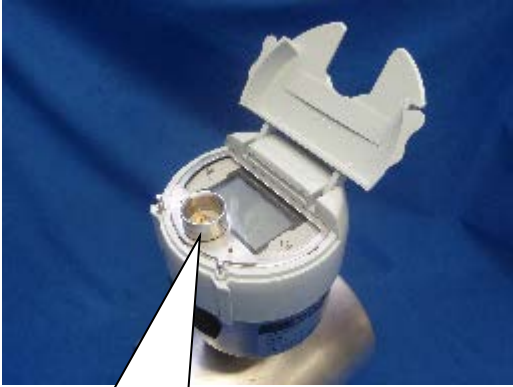

Cross section of connector

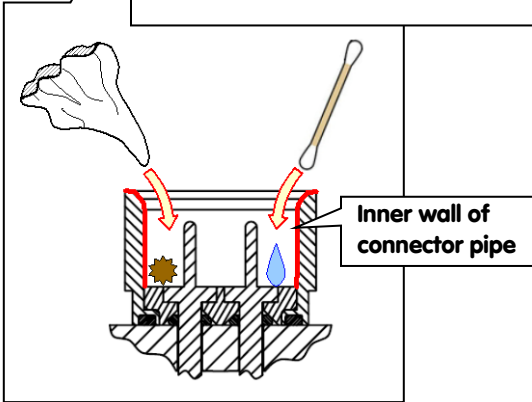

Inner wall of connector pipe

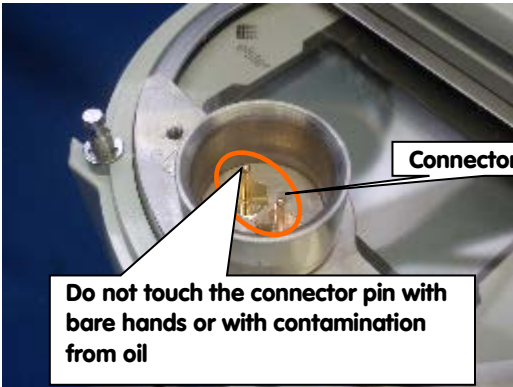

Connector pin

Do not touch the connector pin with bare hands or with contamination from oil

[Step 7]

1. Prevent water or dust ingress into the connector of the meter.
2. Clean the connector of the meter with the cotton swab and the paper towel.
3. Do not let water, moisture, or dust enter the connector of the meter because short circuit or corrosion may occur if the battery pack is attached to the meter in such conditions. Also, this may cause poor sealing.
4. Make sure to clean the inner wall of the connector because the adhesion of dust may make the sealing poor. Note, dust may adhere to this area easily.
5. Do not touch the connector pin with bare hands or soiled or oily materials because this may reduce the quality of the electrical contact.

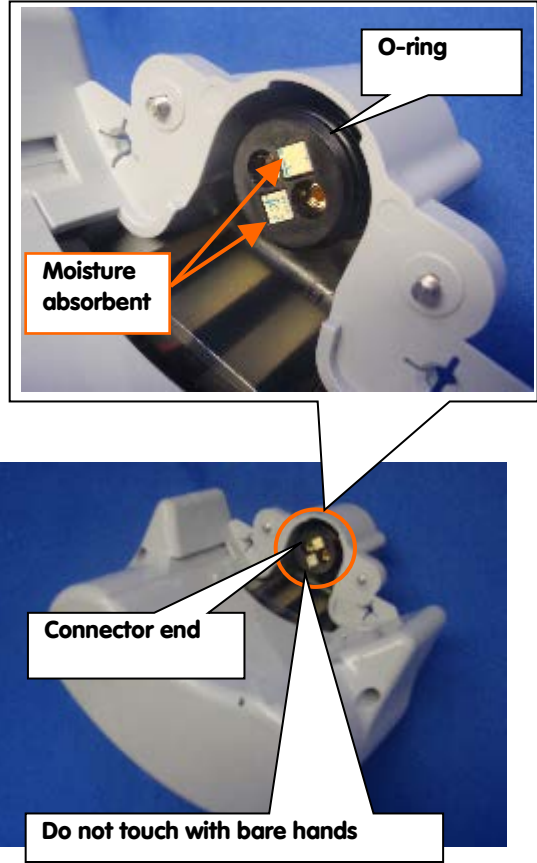

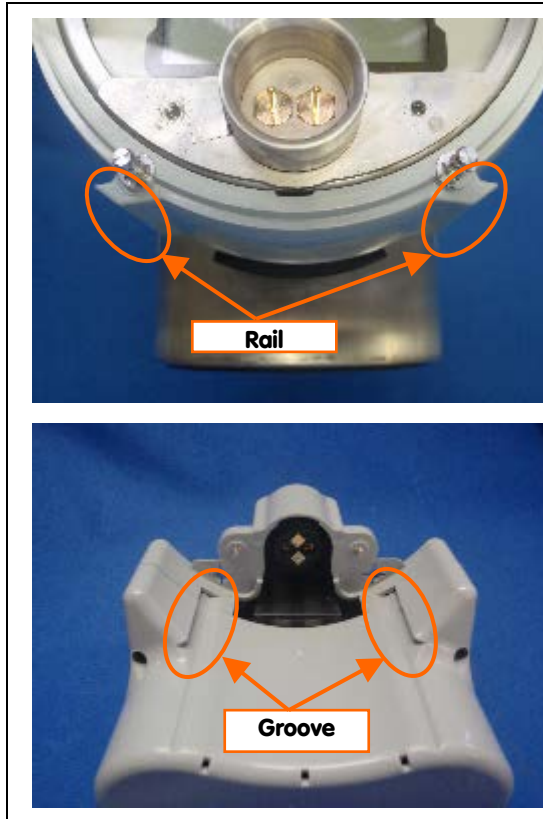
	<p>[Step 8]</p> <ol style="list-style-type: none"> 1. Take out the battery pack and accessories for replacement from the moisture proof bag. 2. Do not open the moisture proof bag till just before the battery pack is used. <p>* If the battery pack is stored in the unpacked moisture proof bag for a long time, the connector may lose insulation properties due to deterioration of the moisture absorbent material fitted into the connector.</p>
	<p>[Step 9]</p> <ol style="list-style-type: none"> 1. Make sure that the moisture absorbent remains fitted into the connector of the battery pack. 2. Do not touch the end of connector with bare hands or anything wet or dirty because the connector could lose the insulation properties due to deterioration of the moisture absorbent. 3. Do not detach the O-ring on the connector of battery pack. 4. Do not let water, moisture, or dust adhere to the O-ring area. 5. Do not use the battery pack if it has been dropped into water or it was submerged in water by mistake.



[Step 10]

Insert the battery pack onto the meter, aligning the grooves of the battery pack through the rails of the meter body.

	<p>[Step 11]</p>
	<ol style="list-style-type: none"> 1. Tighten the right and left torx-screws with the screwdriver by turns while pressing the battery pack downward. 2. Tighten the torx-screws fully. 3. Make sure that the tapered top of the metallic pin is exposed from the boss. 4. Structurally, the mechanism with the metallic pin and the boss protects against tampering. So, once the battery pack is fitted into the meter, the battery pack can never be detached from the meter without cutting out the boss. 5. Do not remove the battery without cutting out the boss.
	<p>* If the battery pack is removed forcibly, the meter and the battery pack may be damaged.</p> <ol style="list-style-type: none"> 6. Do not use a used battery pack that was cut out from the boss or that was removed from the meter. If such the battery pack is used, the boss and pin tamper indication does not work.

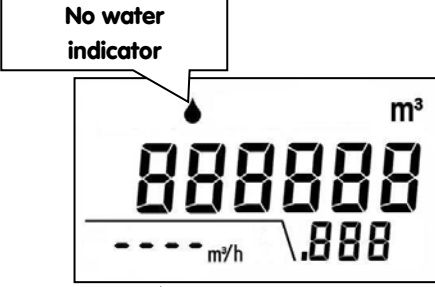
<p>(1) All the indicators turn on. (1.8sec)</p>  <p style="text-align: center;">↓</p> <p>(2) All the indicators turn off. (1.8sec)</p>  <p style="text-align: center;">↓</p> <p>(3) The followings will display at the same time:</p> <ul style="list-style-type: none"> - "No water indicator" blinks. - The accumulated volume just before stopped measurement displays. - The instantaneous flow rate indicator displays 「----」. <p style="text-align: right;">(23.4sec)</p>  <p style="text-align: center;">↓</p>	<p>[Step 12]</p> <p>1. When the battery pack is mounted, the meter enters a power up process; the indicators change as follows:</p> <p>(1) All the indicators turn on. (2) All the indicators turn off. (3) The following items display at the same time:</p> <ul style="list-style-type: none"> - "No water indicator" blinks. - The accumulated volume just before stopping the measurement displays. - The instantaneous flow rate indicator displays 「----」. <p>(4) Then the following is displayed:</p> <ul style="list-style-type: none"> - "No water indicator" blinks. - The accumulated volume just before stopping the measurement displays. - The instantaneous flow rate indicator displays 「0」. <p>(5) After that, the meter resumes normal measurement and operation.</p> <p>* Check that measurement has started, referring to the accumulated volume that was recorded prior to battery removal for replacement.</p> <p>* If all the indicators do not turn on or the "Low battery alarm indicator" does not disappear, the connection between the battery pack and the meter may be bad. Check each step of the attachment process once again.</p> <p>* If you fail to correct the problem, contact Elster AMCO Water Technical Support Team: (866-896-8879), giving us as much detail as possible.</p>
--	--

(4) Then, the following will display at the same time:

- "No water indicator" blinks.
- The accumulated volume just before stopping the measurement displays.
- The instantaneous flow rate indicator displays 「0」.

(36sec)



(5) After that, the meter resumes normal measurement.

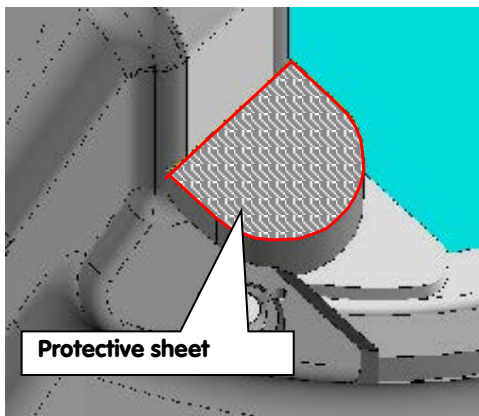
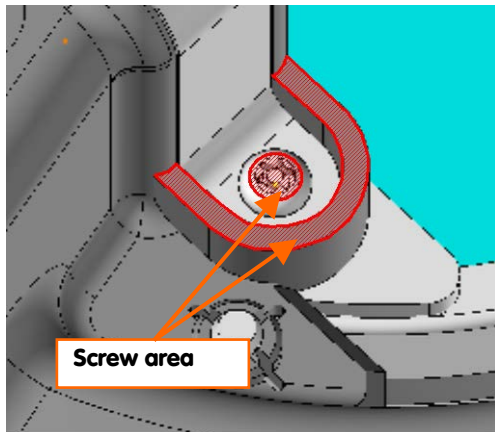

[Step13]

1. Wipe the mud, dust, and water off the screw area.
2. Attach the new protective sheets from the accessories for the replacement on the screw area.

* The protective sheet prevents the screw head from being blocked with the mud or dust.

Fire Service Meter (FSM)

Follow all local, state, and national fire code regulations relating to metered fire service connections.

evoQ₄ FSM are identified by red register shrouds and lids. Meters shipped prior to 2013 include approval for Factory Mutual standard 1044 and bear the FM Approved mark. FSMs shipped beginning 2013 include the UL Listed mark etched into the register shroud. These meters are listed to UL SU327b in addition to the FM approval.

Output Modules

Install a module to the meter per instructions given in the appropriate section above.

For modules factory fitted with specialized connectors (i.e. Nicor connector, Itron™ In-Line Connector) simply attach the meter side connector to the appropriately configured endpoint.

For Mx39 pulse module attachment to Elster or third party electronic equipment with wiring terminals, follow these precautions:

Perform wiring work with clean, dry hands.

Do not allow cable ends to become wet.

Use crimping terminals on the pulse module cable ends is recommended if the electronic device to be attached supports such terminal connections.

Securely attach pulse module wires to the attached device. Be careful to avoid short circuit of the braided wire and terminals. After completing the wiring, lightly pull on the cable to check the wiring connection.

Pass cables through steel conduit away from equipment generating strong magnetic fields. Avoid running cable near power lines, particularly parallel to power lines. When laying cable underground, use conduit.

Do not pull on the cable or allow heavy material to crush, cut, or pinch the cable.

Use an appropriate waterproof splicing kit when splicing additional wire. Contact Elster AMCO Water customer service to order field splice kits. Follow splice instructions and wire diagrams provided in TD520-81.

For MX39 pulse or MX39 Encoder (Elster or Sensus protocol) attached via bare wire splice to AMR/AMI endpoints, these diagrams provide generic wire functions:

Pulse:	Elster protocol encoder:	Sensus protocol encoder:
Red Channel 1	Red Data	Red Data
White Channel 2	White Power (V+)	White Power (V+)
Green Common	Black Common (V0)	Black Common (V0)
Black Tamper	For 2 wire – ignore black	For 2 wire contact Tech support

About Elster AMCO Water LLC

Elster AMCO Water is part of Elster Group, one of the world's largest measurement and communications technology providers for gas, electricity, and water utility industries. We are committed to delivering superior customer service, high quality products, and innovative solutions to the water industry.

About Elster

Elster is a world leader in measuring and improving the flow of natural gas, electricity, and water in more than 130 countries. With one of the most extensive installed revenue measurement bases in the world, and more than 200 million metering modules deployed over the course of the last 10 years alone, Elster enables the vital connections between technology, energy, and critical resources for our global community.

United States
Elster AMCO Water LLC
1100 SW 38th Avenue
Ocala, FL 34474
T 800-874-0890
F 352-368-1950

watermeters@us.elster.com

Caribbean
Elster AMCO Water, Inc.
PO Box 225
Carretera 112 KM 2.3
Isabela, PR 00662
T 787-872-2006
F 787-872-5427

prwatermeters@pr.elster.com

Canada
Elster Canadian Meter Company Inc.
1100 Walker's Line, Suite 101
Burlington, Ontario L7N 2G3
T 866-703-7581
F 905-634-6705

watermeters@ca.elster.com



www.elsteramcowater.com

Copyright © 2013 Elster AMCO Water, LLC. All rights reserved. No part of the publication may be reproduced in any material form without the written permission of Elster AMCO Water except in accordance with the provisions of the Copyright, Designs and Patents Act 1988.

The policy of Elster AMCO Water, LLC is one of continuous improvement and the right is reserved to modify the specifications without notice.

INS-evoQ₄ / 05-13