



**F-4000 Series  
Clamp-on Ultrasonic Flow Meter  
Installation & Basic Operation Guide**



# SAFETY INFORMATION

This meter was calibrated at the factory before shipment. To ensure correct use of the meter, please read this manual thoroughly.

Regarding this Manual:

- This manual should be passed on to the end user.
- Before use, read this manual thoroughly to comprehend its contents.
- The contents of this manual may be changed without prior notice.
- All rights reserved. No part of this manual may be reproduced in any form without ONICON's written permission.
- ONICON makes no warranty of any kind with regard to this material, including, but not limited to, implied warranties of merchantability and suitability for a particular purpose.
- All reasonable effort has been made to ensure the accuracy of the contents of this manual. However, if any errors are found, please inform ONICON.
- ONICON assumes no responsibilities for this product except as stated in the warranty.
- If the customer or any third party is harmed by the use of this product, ONICON assumes no responsibility for any such harm owing to any defects in the product which were not predictable, or for any indirect damages.

Safety Precautions:

The following general safety precautions must be observed during all phases of installation, operation, service, and repair of this product. Failure to comply with these precautions or with specific WARNINGS given elsewhere in this manual violates safety standards of design, manufacture, and intended use of the product. ONICON Incorporated assumes no liability for the customer's failure to comply with these requirements. If this product is used in a manner not specified in this manual, the protection provided by this product may be impaired.

The following symbols are used in this manual:



## WARNING

Messages identified as "Warning" contain information regarding the personal safety of individuals involved in the installation, operation or service of this product.



## CAUTION

Messages identified as "Caution" contain information regarding potential damage to the product or other ancillary products.



## IMPORTANT NOTE

Messages identified as "Important Note" contain information critical to the proper operation of the product.

# TABLE OF CONTENTS

1.0	INTRODUCTION .....	5
1.1	PURPOSE OF THIS GUIDE .....	5
1.2	PRINCIPLE OF OPERATION .....	5
1.3	TYPICAL FLOW METER INSTALLATION .....	5
1.4	STANDARD FEATURES AND SPECIFICATIONS.....	6
1.5	MAINTENANCE .....	7
1.6	ADDITIONAL REQUIRED HARDWARE.....	7
1.7	ADDITIONAL HARDWARE THAT MAY BE REQUIRED.....	7
1.8	WORKING ENVIRONMENT .....	7
1.9	WARRANTY AND SERIAL NUMBER .....	7
2.0	UNPACKING .....	8
2.1	CHECKING THAT YOU HAVE RECEIVED EVERYTHING .....	8
3.0	INSTALLATION.....	9
3.1	OVERVIEW .....	9
3.2	SITE SELECTION.....	10
3.3	MECHANICAL INSTALLATION.....	12
3.3.1	Mounting the Enclosure .....	12
3.3.2	Preparing the Pipe .....	13
3.3.3	Reflect Mode Mounting Using Frames and Spacer Bar.....	13
3.3.4	Reflect Mode Mounting Using Track Mount Hardware .....	14
3.3.5	Direct Mode Mounting Using Brackets and Spacer Bar.....	16
3.3.6	Direct Mode Mounting Using Track Mount Hardware.....	20
3.3.7	Installing Transducers In Bracket and Spacer Bar Hardware .....	22
3.3.8	Installing Transducers In Track Mount Hardware.....	23
3.4	CONNECTING THE TRANSDUCER SIGNAL CABLES .....	24
3.5	INSTALLING THE F-CONNECTORS.....	25
3.5.1	Cable Preparation.....	25
3.5.2	Cable & Connector Assembly .....	25
3.5.3	Final Assembly .....	25
3.6	ELECTRICAL INSTALLATION .....	26
3.6.1	Input Power Options .....	26
3.6.2	Electrical Connections.....	27

4.0	START-UP .....	29
4.1	PROGRAM MODE KEYPAD FUNCTIONS .....	29
4.2	RECALLING A SAVED SITE .....	30
4.3	INSTALLING RECALLED SITES.....	31
4.3.1	Reflect Mount Installations .....	31
4.3.2	Direct Mount Installations.....	32
4.4	NAVIGATING THE RUN MODE MENU PAGES.....	33
5.0	COMMISSIONING FOR ONICON CLAMP-ON ULTRASONIC FLOW METERS.....	35
5.1	HELPFUL HINTS FOR START-UP AND COMMISSIONING.....	35
5.2	COMMISSIONING PROCEDURE .....	35
5.3	COMMISSIONING WORKSHEET .....	37
6.0	TROUBLESHOOTING.....	38

## APPENDIX

A-1	SONIC VELOCITY RELATIVE TO TEMPERATURE OF PURE WATER
A-2	F-4000 SERIES MOTHER BOARD
A-3	CONDITIONS OF SALE

# SECTION 1.0: INTRODUCTION

## 1.1 PURPOSE OF THIS GUIDE

The purpose of this guide is to provide installation and commissioning procedures and basic operating and servicing instructions for the ONICON F-4000 Series Ultrasonic Flow Meter.

## 1.2 PRINCIPLE OF OPERATION

ONICON F-4000 Series Ultrasonic Flow Meters utilize the differential transit time method to measure the velocity of relatively clean liquids in full pipes. By measuring the difference between transit times of ultrasonic sound waves travelling between two transducers, the flow velocity and direction are accurately determined.

## 1.3 TYPICAL F-4000 FLOW METER

The F-4000 Series Ultrasonic Flow Meter utilizes clamp-on signal transducers that mount on the outside wall of the pipe. It is suitable for measuring the volumetric flow of liquids in a wide variety of applications including bi-directional flow applications. The meter is housed in a steel wall-mounted enclosure with a built-in user interface/display.

### TYPICAL INSTALLATION

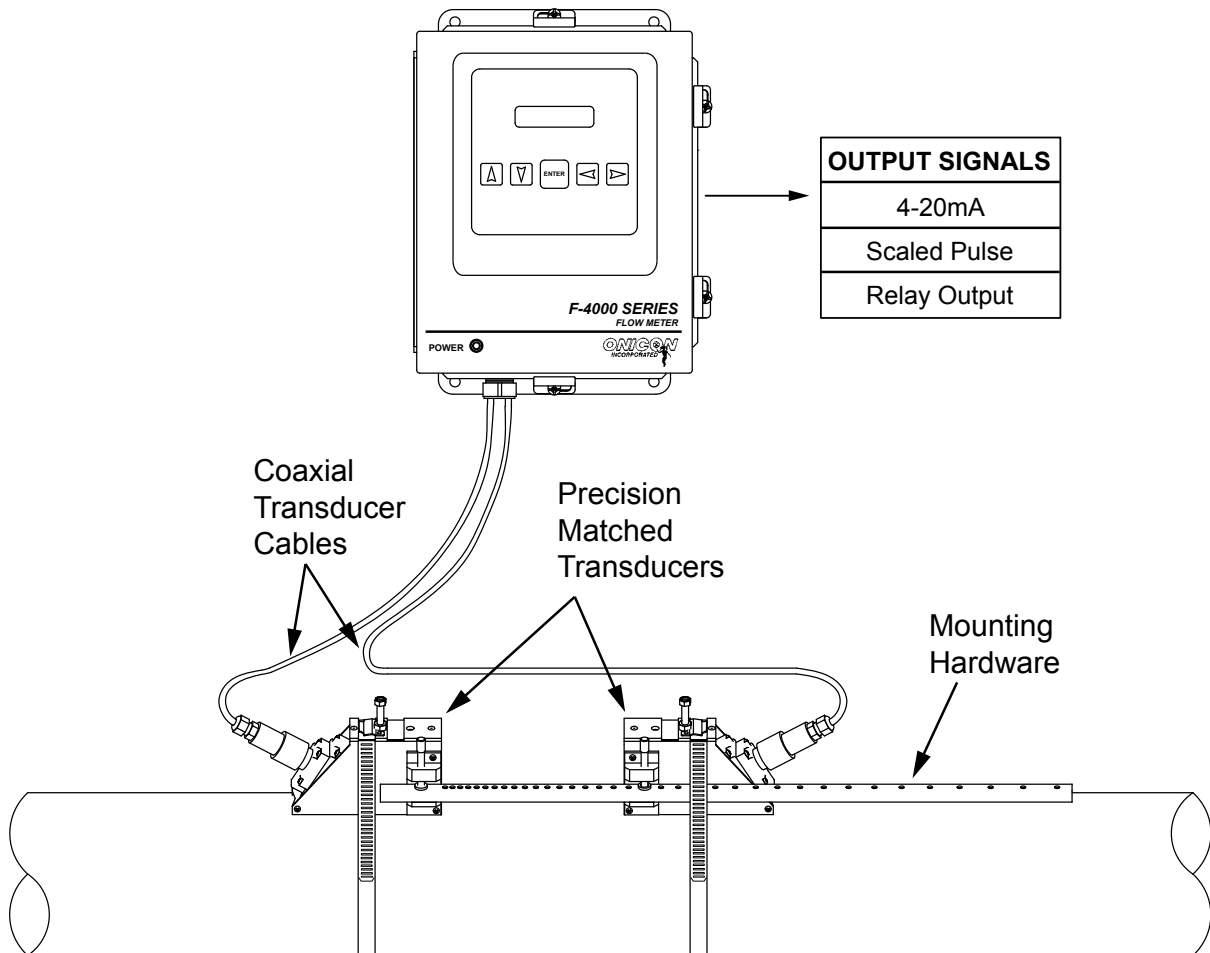

## 1.4 STANDARD FEATURES AND SPECIFICATIONS

- Wall-mounted NEMA 4 steel enclosure with 2-line alphanumeric user interface/display
- One externally powered electrically isolated 4-20 mA analog output for flow rate
- One scalable electrically isolated open collector pulse output for totalizing flow
- One programmable form C relay to indicate flow direction or alarm.

### GENERAL SPECIFICATIONS

#### ACCURACY

- ± 1.0% of reading from 1 to 40 ft/sec
- ± 0.01 ft/s for velocities below 1 ft/sec

#### OVERALL FLOW RANGE

0.1 to 40 ft/sec

#### SENSING METHOD

Clamp-on ultrasonic, differential transit time method in direct or reflect mode

#### PIPE SIZE RANGE

½" through 48" nominal diameter

#### PROGRAMMING

Factory programmed for specific application

#### MEMORY

Non-volatile memory retains all program parameters and totalized values in the event of power loss.

#### DISPLAY

Alphanumeric 2-line, 16-characters per line multifunction LCD display  
(Character height, 0.2")

Displays total flow, flow rate, speed of sound, % gain, % aeration, signal strength, flow direction & alarm conditions

Rate display range: 0 - 9,999,999

Totalizer display range: 0 - 99,999,999

Totalizers will roll over to zero when maximum count is exceeded.

#### OUTPUT SIGNALS PROVIDED

Analog output: Electrically isolated 4-20 mA  
(Externally powered 10 - 30 VDC)

Scalable pulse output: Optically isolated open collector (Contact rating: 30 VDC, 10 mA maximum, pulse duration: 50 ms)

Relay output for flow direction or alarm:  
Programmable form C relay (Contact rating: 30 VDC, 250 mA maximum)

#### FLUID TEMPERATURE RANGE

Standard: -40° F to 250° F

Optional: High Temperature -40° F to 446° F

#### AMBIENT OPERATING TEMPERATURE RANGE

14° F to 122° F

#### STORAGE TEMPERATURE RANGE

-4° F to 140° F

### MECHANICAL

#### MATERIALS OF CONSTRUCTION

Electronics enclosure: Wall-mount, powder coat painted steel enclosure with stainless steel hardware

Transducer mounting hardware: Anodized aluminum and stainless steel

Transducers: Anodized aluminum and plastic

#### ENCLOSURE RATINGS

NEMA 4, weathertight

### ELECTRICAL

This equipment is intended for INSTALLATION CATEGORY (OVERVOLTAGE CATEGORY) II applications. Installations must comply with all local, state and federal building codes.

#### INPUT POWER – Factory selectable

11.5 to 28.5 VDC, 10 Watts maximum  
(Internal: 5x20mm, 250V/2.0A fuse)

90-240 VAC 50/60 Hz, 15 VA maximum  
(Internal: 5x20mm, 250V/0.5A fuse)

#### OVERCURRENT PROTECTIVE DEVICE RATINGS:

Supply mains overcurrent protective devices with the following ratings:

120 VAC 50/60 Hz – 15 A

230 VAC 50 Hz – 6 A

#### ELECTRICAL CONNECTIONS

Enclosed terminal connections, cable access through four standard ¾" conduit openings

Transducer signals: (2) F-connectors supplied with quick-disconnect adapters

Input power: 3 terminal removable connectors  
(12 - 22 AWG)

Signal inputs/outputs: PCB mount terminal blocks  
(14 - 26 AWG)

#### WIRING

Transducer signals: Use Belden 9269 coaxial cable or equivalent (93Ω nominal impedance)

24 VDC input power: Use PVC jacketed copper cable with a wire gauge suitable for the length of run and required maximum current carrying capacity.

Provide a separate protective earth wire.

120/230 VAC input power: Use a 3-wire service with one wire a protective earth ground.

Signal inputs/outputs: Use PVC jacketed copper shielded cable with a wire gauge suitable for the length of run and required maximum current carrying capacity.

## 1.5 MAINTENANCE

Periodically inspect the power cables, transducer cables, cable glands and the enclosure for signs of damage. Inspect transducer installation and mounting hardware for loose connections.

## 1.6 ADDITIONAL REQUIRED HARDWARE

Installation hardware: ONICON clamp-on ultrasonic flow meters typically require installation hardware. Hardware requirements vary by pipe size and material.

## 1.7 ADDITIONAL HARDWARE THAT MAY BE REQUIRED

Flex conduit may be required to connect transducer to rigid conduit. Do not connect transducers to rigid conduit.

## 1.8 WORKING ENVIRONMENT

The F-4000 was designed for installation and use in typical commercial/industrial environments. The following considerations must be observed in selecting a location for the meter:

- The ambient operating temperature range is 14° F (-10° C) to 122° F (50° C).
- Do not expose the meter to corrosive liquids or fumes.
- Avoid installation locations that are close to strong sources of electrical interference.
- Avoid installing the electronics enclosure in direct sunlight.
- Avoid installation locations where the transducers will be exposed to vibrations in the piping system.
- Always run transducer cables in dedicated conduit separate from signal and power cables.
- Do not run signal cables for the meter in conduit with mains (AC) power cables.

## 1.9 WARRANTY & SERIAL NUMBER

### Warranty

ONICON provides a 2-year warranty for this product. Certain exclusions apply. Please refer to ONICON's Conditions of Sale for details.

### Serial Number

The serial number of your F-4000 is located outside and inside the enclosure. All components of your F-4000 (electronics enclosure & transducers) will bear identical serial numbers. Serial numbers are unique identifiers that you should have available when contacting ONICON for assistance regarding your meter.

## **SECTION 2.0: UNPACKING**

The F-4000 is generally shipped in one package unless optional hardware or equipment is ordered. Notify the freight carrier (all products are shipped insured) and ONICON if any items are damaged in transit.

### **2.1 CHECKING THAT YOU HAVE RECEIVED EVERYTHING**

- **Standard Documentation**

Enclosed with each F-4000 is a comprehensive documentation package that includes the following items:

- This F-4000 Ultrasonic Flow Meter Installation and Operation Guide
- The Flow Meter Certificate of Calibration
- Site Installation Details Document

Please notify ONICON if any of these items are missing.

#### **IMPORTANT NOTE**

**i** The ONICON F-4000 Ultrasonic Flow Meter is a custom calibrated system. Unless specifically noted in writing by ONICON, ALL COMPONENTS (electronics enclosure and ultrasonic transducers) share the same serial number and must be installed together as a system. Mixing components from different systems will result in significant errors in calibration.

- **The Wall Mount Enclosure**

Remove the F-4000 enclosure from the shipping carton and inspect it inside and out for physical damage. Please notify ONICON immediately if you discover any damage.

Transducers are shipped in the same carton with the enclosure. Inspect the transducers for signs of damage. Each transducer will have a label attached with a serial number identical to that found on the F-4000 enclosure. Included with the transducers are two dry coupling pads and one tube of coupling compound.

- **Transducers Cables**

Transducer cables are coiled and packed separately in the outer carton. Taped to the cables is a termination kit that includes the fittings necessary to terminate the transducer end of the cables. The other end of each cable is already terminated.

- **Installation Hardware**

Installation hardware may include mounting brackets and a spacer bar or a track mount assembly. Taped to this hardware will be a mounting strap kit. This kit includes the mounting straps used to secure the hardware onto the pipe, a sanding block for preparing the pipe surface, and a mylar mounting guide used when mounting transducers in direct operating mode. The kit will also include a copy of the F-4000 Site Installation Details for this meter. This document provides specific details such as transducer spacing. This information is unique to the specific installation site and is identified by the meter location tag name and the serial number of the meter.



## SECTION 3.0: INSTALLATION

### 3.1 OVERVIEW

Each F-4000 Series Ultrasonic Flow Meter is provided with a pair of precision matched ultrasonic transducers. The transducers are mounted (clamped) on to the outside wall of the pipe. Coaxial cables convey the transducer signals to the wall mount enclosure containing the signal processing circuitry and the user interface display. Ultrasonic transducers can be configured to operate in either reflect or direct operating modes. The choice of operating mode is dictated by the configuration settings programmed into the meter. For new installations, configuration data is programmed into the meter prior to shipment. This data is saved as a “Site”. Site data determines the transducer operating mode and the spacing between the transducers. This information is provided with the installation hardware in a document titled, “F-4000 Site Installation Details”.

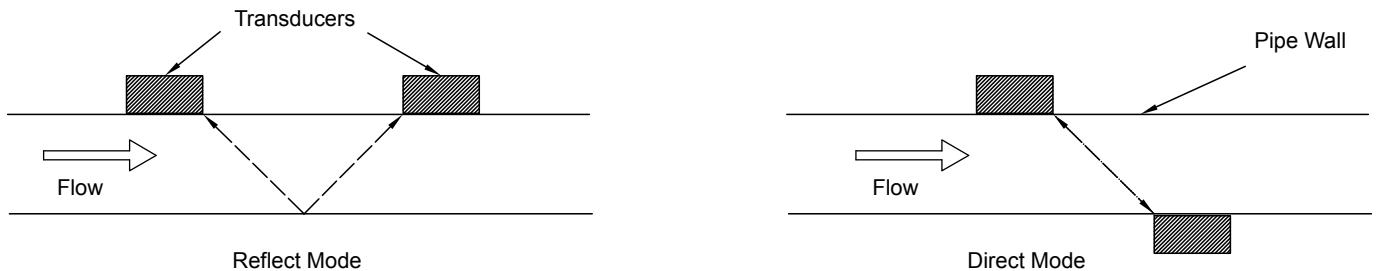

#### **Reflect Mode**

Reflect mount is the recommended operating mode whenever possible. It is the simplest way to mount the transducers. Operating in the reflect mode also minimizes the effects of some flow distortions and enables the use of the auto zero function.

#### **Direct Mode**

Direct mount provides a shorter sonic beam path. This usually improves performance with sonically attenuative liquids or pipe materials. Direct mount is required for plastic pipes. Direct mounting only requires half the distance between electrodes when compared to the reflect mode and may be the only option if the availability of mounting space is limited.

## 3.2 SITE SELECTION

Careful attention to the site selection for the system components will help the installers with the initial installation, reduce start-up problems and make future maintenance easier. For example, do not install the meter where it will be difficult for personnel to perform periodic maintenance. When selecting a site for mounting the system components, consider the criteria under Section 1.8 WORKING ENVIRONMENT, as well as the following:

### The Wall-Mount Enclosure

Find an easily accessible location where wire connections can be made and meter readings can be taken from floor level. Mount the enclosure on a vibration-free surface. Avoid sites such as the plenum of a fan coil, heat exchanger, or other housings containing motors. Avoid mounting the enclosure in close proximity to VFD's, electric motors or other strong sources of electrical interference.



#### IMPORTANT NOTE

The maximum allowable distance between the wall-mount enclosure and the transducers installed on the pipe is 300 feet.

## The Transducers

For best results, the transducers must be installed on a straight run of pipe, free of bends, tees, valves, transitions, insertion probes and obstructions of any kind. For most installations, ten straight unobstructed pipe diameters upstream and five diameters downstream of the transducers is the minimum recommended distance for proper operation. Additional considerations are outlined below.

**i**

### IMPORTANT NOTE

In some cases, longer straight runs may be necessary where the transducers are placed downstream from devices which cause unusual flow profile disruptions or swirl; for example, modulating valves or two elbows in close proximity and out of plane, etc.

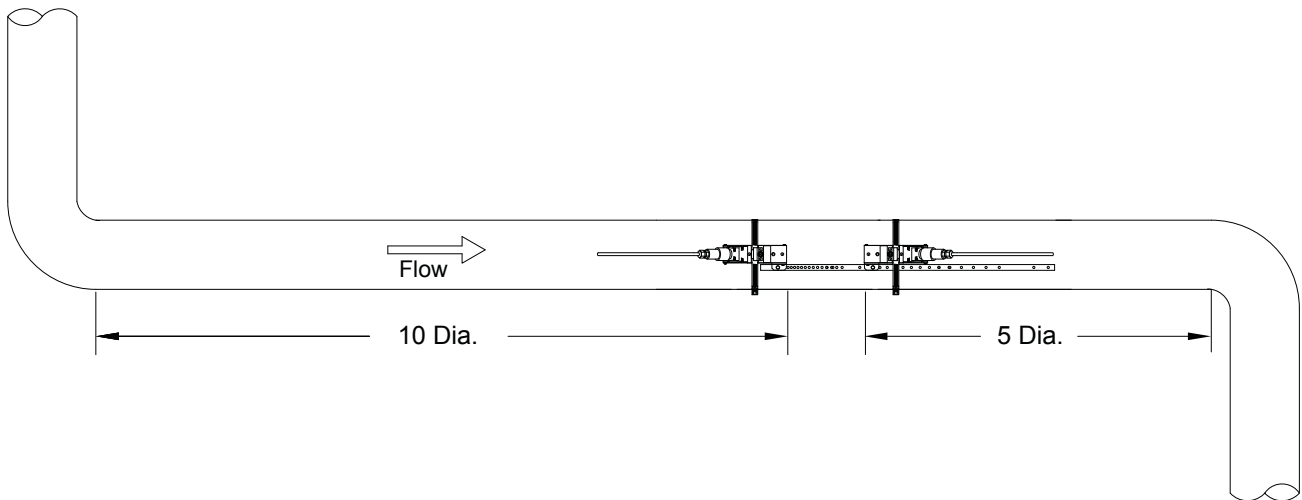

- Do not, if possible, install the transducers downstream from a throttling valve, a mixing tank, the discharge of a positive displacement pump or any other equipment that could possibly aerate the liquid. The best location will be as free as possible from flow disturbances, vibration, sources of heat, noise, or radiated energy.
- Avoid mounting the transducers on a section of pipe with any external scale. Remove all scale, rust, loose paint, etc., from the location prior to mounting the transducers.
- Do not mount the transducers on a surface aberration (pipe seam, etc.).
- Do not mount transducers from different ultrasonic flow meters on the same pipe.
- Do not run the transducer coaxial cables in common bundles with cables from other instrumentation. You can run these cables through a common conduit ONLY if they originate at the same flow meter.
- Never mount transducers under water, unless you have specifically purchased submersible transducers and you install them in accordance with factory instructions.
- Avoid mounting transducers on the top of a horizontal pipe. The best placement on a horizontal pipe is either the 10:00 or 2:00 position for reflect mode, or one sensor at 9:00 and one sensor at 3:00 for direct mode.
- Do not mount transducers on the bottom of a horizontal pipe.
- Mounting on a vertical pipe is recommended only if flow is in the upward direction. When mounting on a vertical pipe flowing in a downward direction, make sure there is sufficient back pressure in the system to maintain a full pipe.

### 3.3 MECHANICAL INSTALLATION

#### IMPORTANT NOTE



This ONICON F-4000 Ultrasonic Flow Meter is a custom calibrated system. Unless specifically noted in writing by ONICON, ALL COMPONENTS (electronics enclosure and precision matched transducers) share the same serial number and must be installed together as a system. Mixing components from different systems will result in significant errors in calibration.

#### 3.3.1 Mounting the Enclosure

Find an easily accessible location where electrical connections can be made and meter readings can be taken from the floor level. Mount the enclosure on a vibration-free surface. Avoid sites such as the plenum of a fan coil, heat exchanger, or other housings containing motors. Avoid mounting the enclosure in close proximity to VFD's, electric motors or other strong sources of electrical interference.

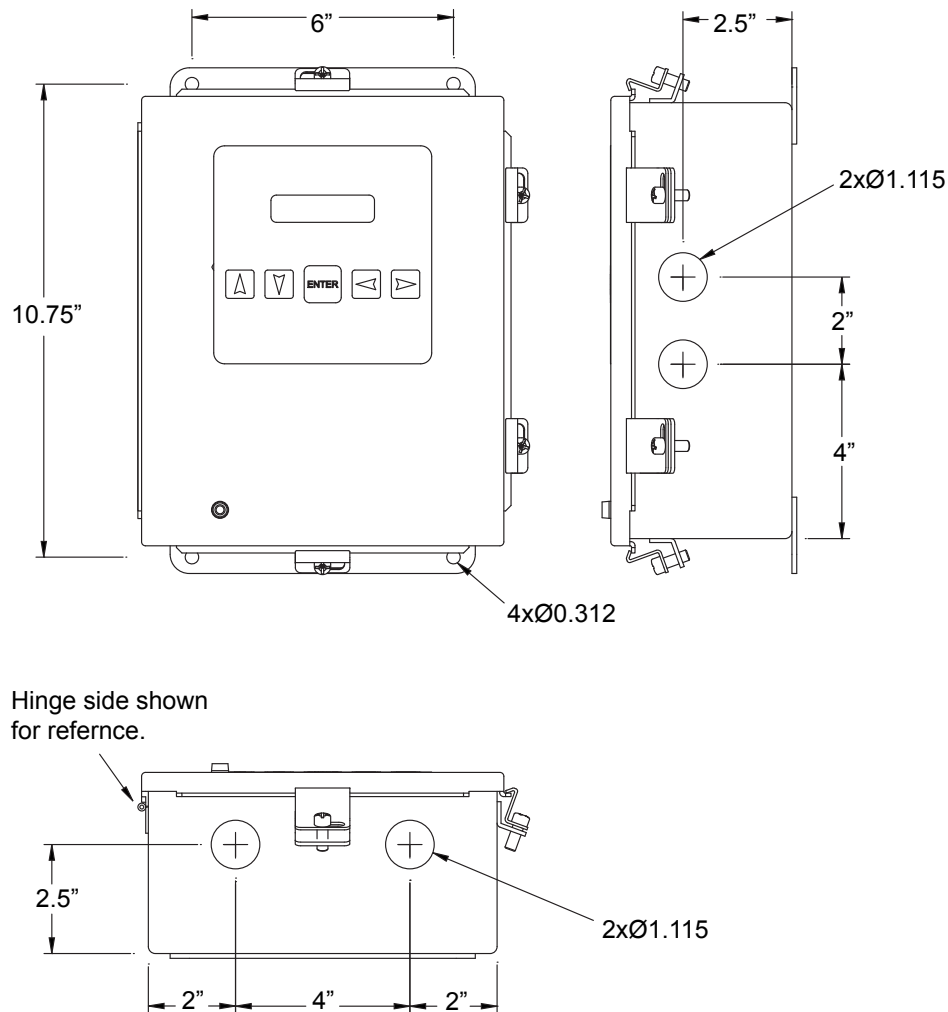

#### CAUTION



Do not drill additional holes in this enclosure. Doing so may damage the electronic circuitry contained within and will void all warranties.

### 3.3.2 Preparing the Pipe

Once a suitable section of straight pipe has been located, the pipe surface must be prepared. Refer to the Site Installation Details document provided with the installation hardware to determine the transducer spacing dimensions. Prepare the pipe surface as shown below. Clean and de-grease two rectangles where the transducers will be located. Use the small sanding block provided with the installation hardware as necessary to remove any grit, corrosion, rust, loose paint or other contaminants. The cleaned surface should extend at least ½” beyond the length and width of the transducers.

Always install hardware at the 10:00 or 2:00 position on horizontal pipes. This prevents the flow meter from being affect by air trapped at the top of the pipe.

Refer to site installation details document for transducer spacing.

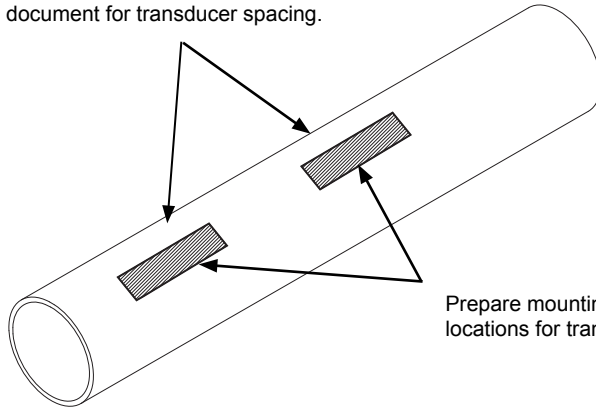

Prepare mounting locations for transducers.

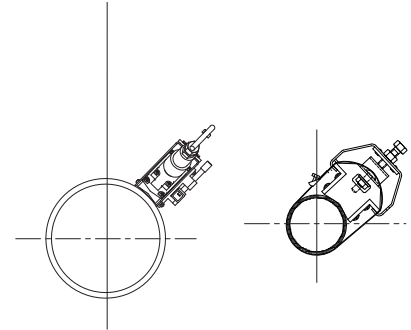

For horizontal pipes, locate transducers at the 10:00 or 2:00 position.

### 3.3.3 Reflect Mode Mounting Using Frames and Spacer Bar

1. Prepare the pipe surface as described in section 3.3.2.
2. On a flat surface, assemble the hardware as shown in the drawing below.

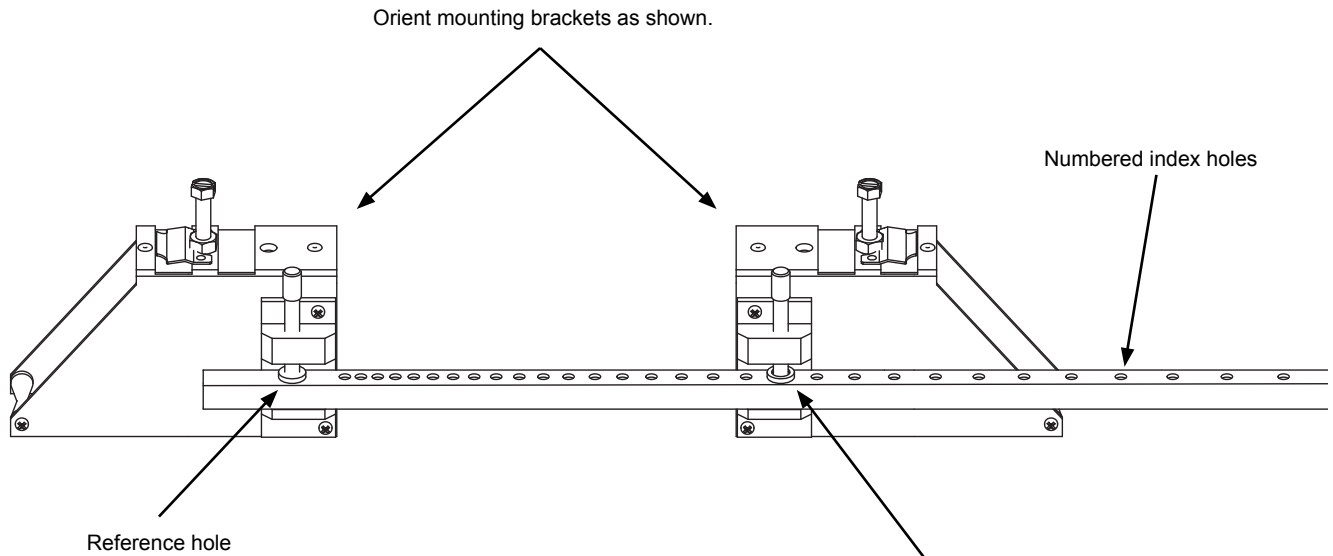

Orient mounting brackets as shown.

Numbered index holes

Reference hole

Refer to the Site Installation Details document provided with the installation hardware to determine the correct hole location.

3. Install the mounting straps as shown below. For larger pipes, use multiple straps connected end-to-end to increase the length of each strap. Leave enough slack in the straps to allow the assembly to be correctly positioned on the pipe.

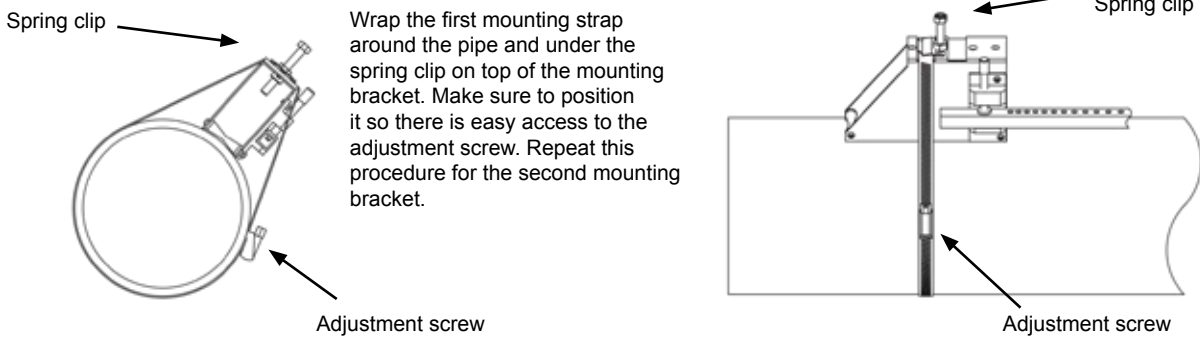

4. Move the hardware assembly to its final position on the pipe. Align the brackets with the prepared surface for each transducer as shown below, ensuring that the entire assembly is properly oriented along the axis of the pipe. Tighten the assembly firmly on the pipe. Do not over tighten the straps.

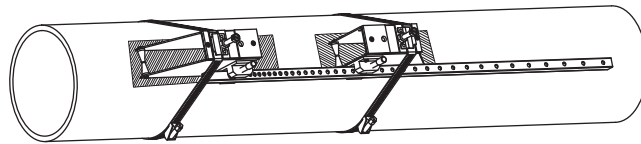

### 3.3.4 Reflect Mode Mounting Using Track Mount Hardware

1. Prepare the pipe surface as described in section 3.3.2.
2. Place the track mount hardware assembly at the 10:00 or 2:00 position on the pipe at the desired mounting location. Ensure that it is a clean, smooth area without any raised spots or seams.

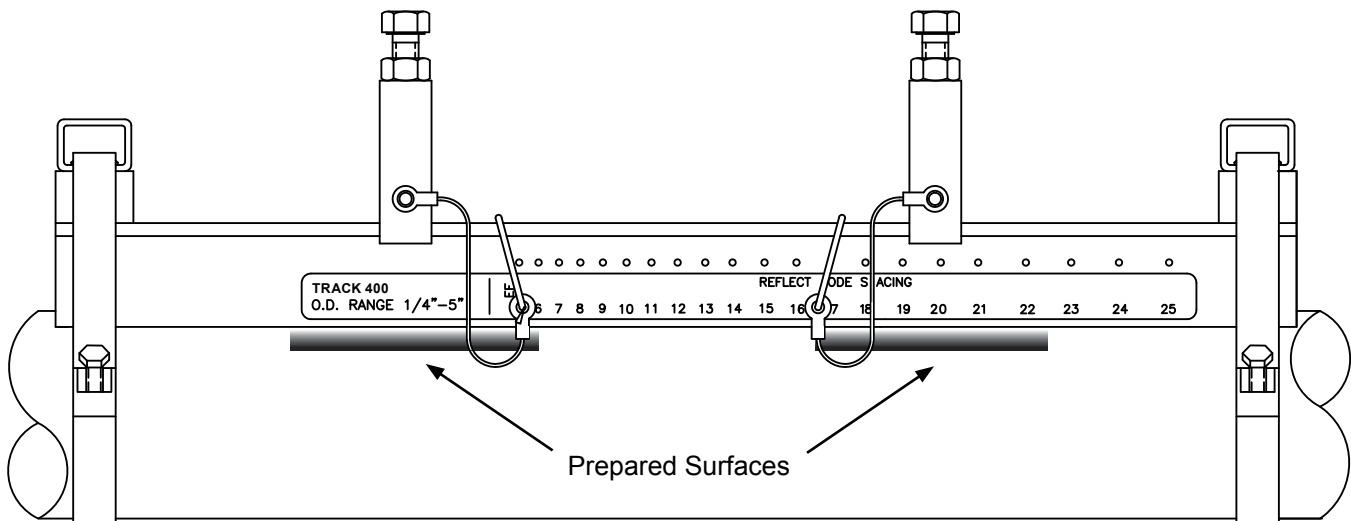

3. Holding the track mount assembly in place, wrap one of the mounting straps around the pipe as shown in the drawing below. Tighten the tension screw enough to hold the assembly on the pipe, but still allow rotation. Repeat for the other mounting strap.

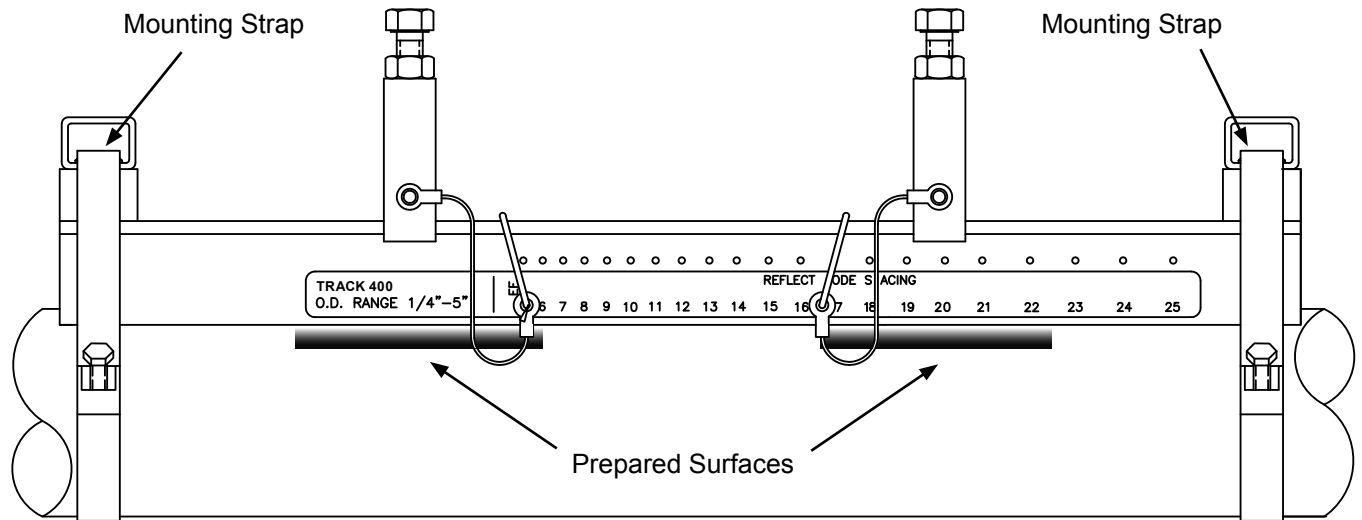

4. Rotate the track mount assembly as necessary to its final intended mounting position on the pipe, then tighten both tension screws just enough to prevent rotation. Do not over tighten.

### 3.3.5 Direct Mode Mounting Using Brackets and Spacer Bar

1. Once the installation site selection process described in section 3.2 is complete, prepare the pipe where the first sensor will be mounted.

#### IMPORTANT NOTE

Direct mode mounting requires that transducers be installed on opposite sides of the pipe. For horizontal pipes, the transducers should be located at the 3 o'clock and 9 o'clock positions.

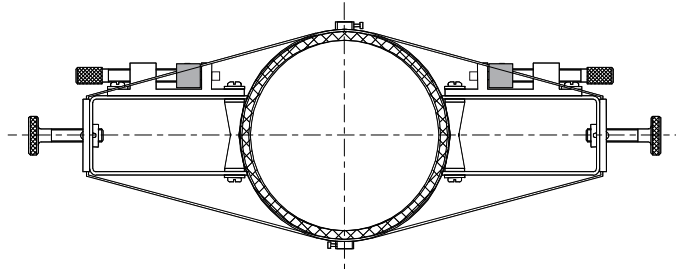

i

2. To prepare the pipe, temporarily position a mounting bracket on the pipe where you will be mounting it. Ensure that the pipe surface is smooth without any raised areas (seams, etc.) With a pencil, marker or chalk, draw a generous rectangle around the bracket. Clean and de-grease the area within the rectangle. Use the small sanding block provided with the installation hardware as necessary to remove any grit, corrosion, rust, loose paint or other contaminants. Be sure to wipe the surface clean after sanding. The cleaned surface should extend at least ½" beyond the length and width of the mounting bracket.

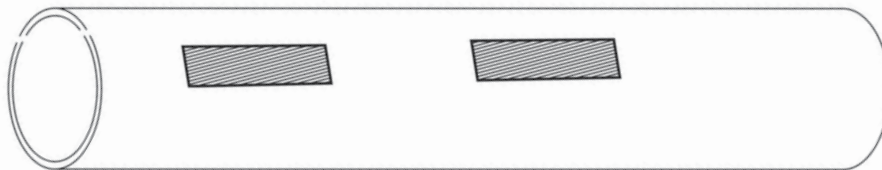

3. Attach the spacer bar to one of the mounting brackets at the reference hole.

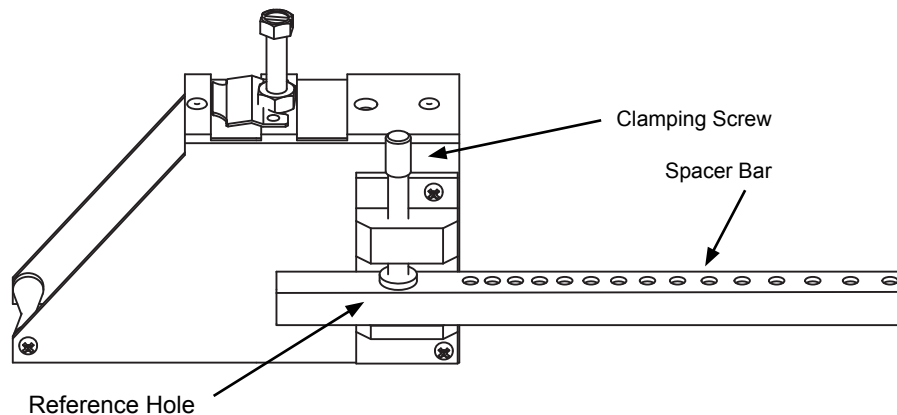



- Position the mounting bracket and spacer bar in the center of the cleaned area and secure it in place with a mounting strap as shown below. Make sure the mounting strap tightening screw is facing up. Note that the angled end of the bracket must be facing away from where the other bracket will be mounted. While tightening the strap, check to ensure that the bracket remains centered on the pipe. (The bracket is centered on the pipe when the bottom edges of both aluminum side plates on the bracket are in full contact with the pipe surface.)

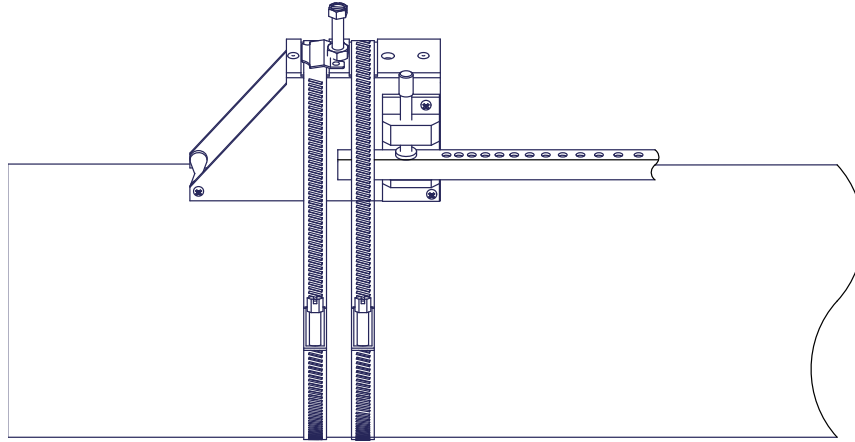

- Attach the second bracket to the spacer bar at the numbered index hole specified on the site installation details document provided with the installation hardware. Note that the angled end of the bracket must be facing away from the other mounting bracket.

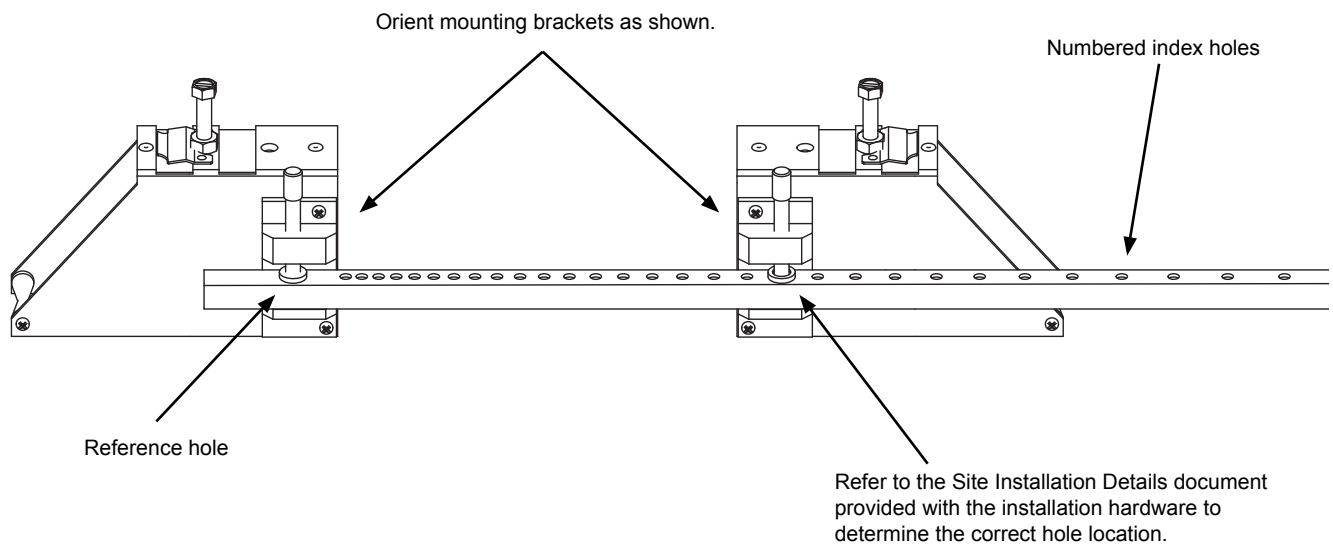

- Check to ensure that this bracket is lined up on the center of the pipe. While holding the bracket centered on the pipe, place a mark (with pencil or chalk) at the center of the tapered roller at the bottom of the bracket as shown below. Next, mark along the edge of the bracket as indicated in the drawing below.

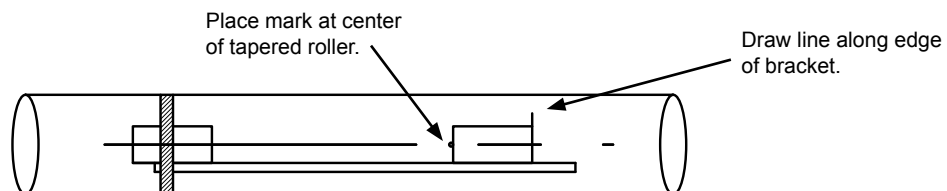

- Remove the bracket from the spacer bar and then remove the spacer bar from the bracket that is strapped to the pipe. Using the spacer bar as a straight edge, draw a line down the center of the pipe intersecting the mark made at the center of the tapered roller and the line drawn against the edge of the bracket as shown below.

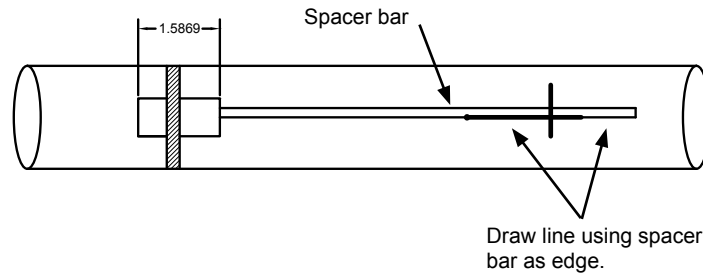

- Wrap the Mylar spacing guide around the pipe so that the left edge is against the transducer edge mark. Arrange so that one end overlaps the other. Ensure that it is snug around the pipe and mark along the overlapping edge.

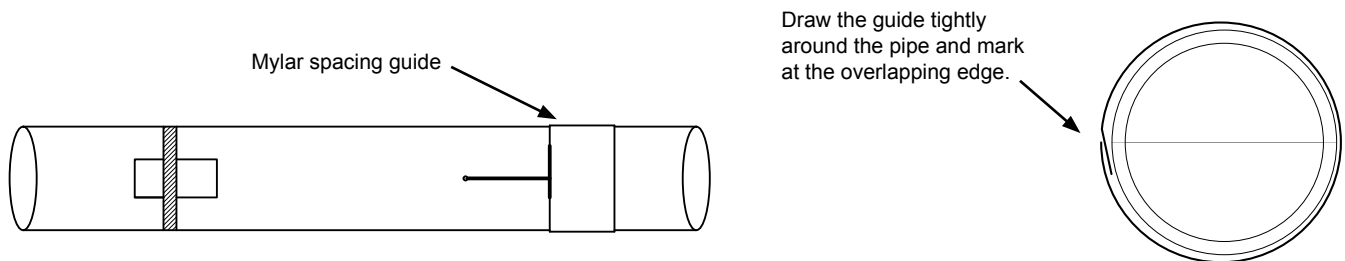

- Remove Mylar spacing guide and lay it out on a flat surface. Either measure the exact distance half-way between the overlap edge and the mark at the overlap, or fold the guide from the overlap edge to overlap mark and draw a line at the fold or halfway point.

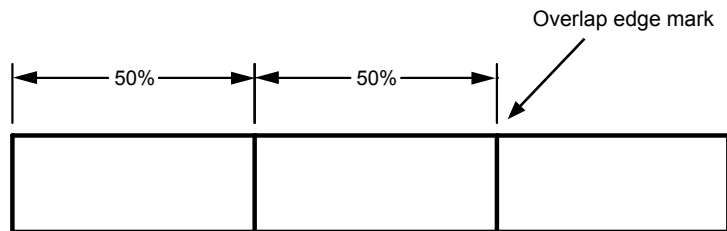

- Reinstall the spacing guide; its edge abutting the bracket edge mark on the pipe and the overlapping edge in line with the line drawn down the center of the pipe. Tape it in this position on the pipe. Take the second bracket and place it against the edge of the guide with its tapered roller centered on the half way mark drawn on the guide.

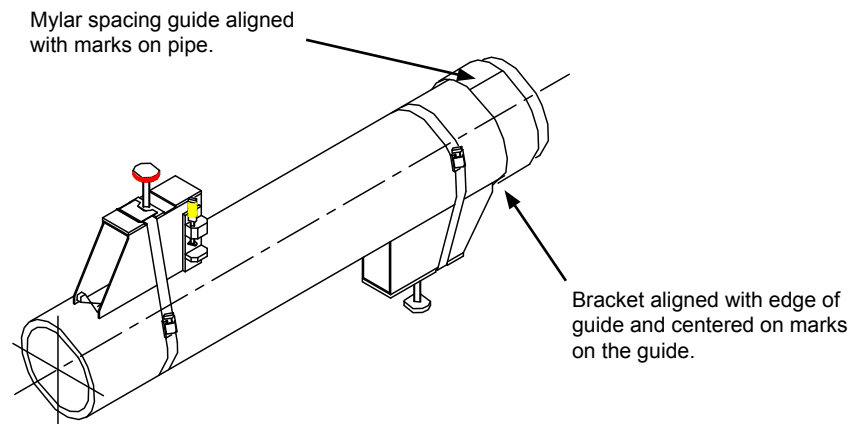

11. Ensure that the bracket is sitting on a smooth area without any raised spots (seams, etc.). Mark a generous rectangle around the bracket with a pencil, marker or chalk. Remove the bracket and the Mylar guide.
12. Clean and de-grease the area within the rectangle. Use the small sanding block provided with the installation hardware as necessary to remove any grit, corrosion, rust, loose paint or other contaminants. The cleaned surface should extend at least ½” beyond the length and width of the mounting bracket.

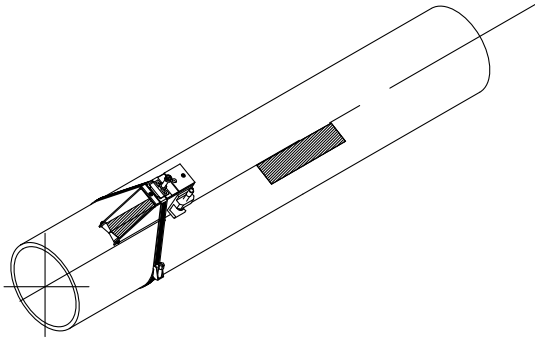

13. Replace the Mylar guide back in the same position it was in and re-tape it to the pipe.
14. Position the bracket as before against the edge of the guide with its tapered roller centered on the half way mark drawn on the guide. Secure it in place with a mounting strap as shown below. Make sure the mounting strap tightening screw is facing toward the bracket so you can hold it in place while tightening the screw. Note that the angled end of the bracket must be facing away from where the other bracket will be mounted. While tightening the strap, check to ensure that the bracket remains centered on the pipe. (The bracket is centered on the pipe when the bottom edges of both aluminum side plates on the bracket are in full contact with the pipe surface.)

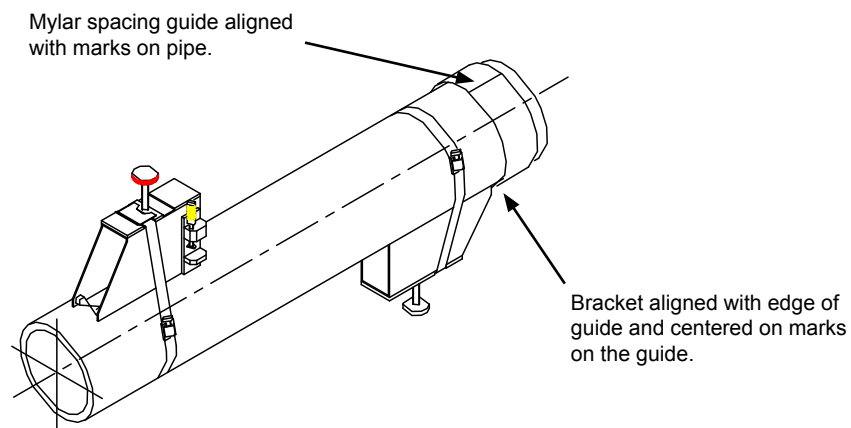

### 3.3.6 Direct Mode Mounting Using Track Mount Hardware

1. Once the installation site selection process described in section 3.2 is complete, prepare the pipe where the first sensor will be mounted.



**IMPORTANT NOTE**

Direct mode mounting requires that transducers be installed on opposite sides of the pipe. For horizontal pipes, the transducers should be located at the 3 o'clock and 9 o'clock positions.

2. To prepare the pipe, temporarily position one track mount hardware assembly on each side of the pipe where you intend to permanently mount them as shown below. Ensure that pipe surface is smooth without any raised areas (seams, etc.) With a pencil, marker or chalk, draw a rectangle around each track mount assembly. Remove the hardware from the pipe and clean and de-grease the area within the rectangles. Use the small sanding block provided with the installation hardware as necessary to remove any grit, corrosion, rust, loose paint or other contaminants. Be sure to wipe the surface clean after sanding. The cleaned surface should extend at least 1/2" beyond the length and width of each assembly.

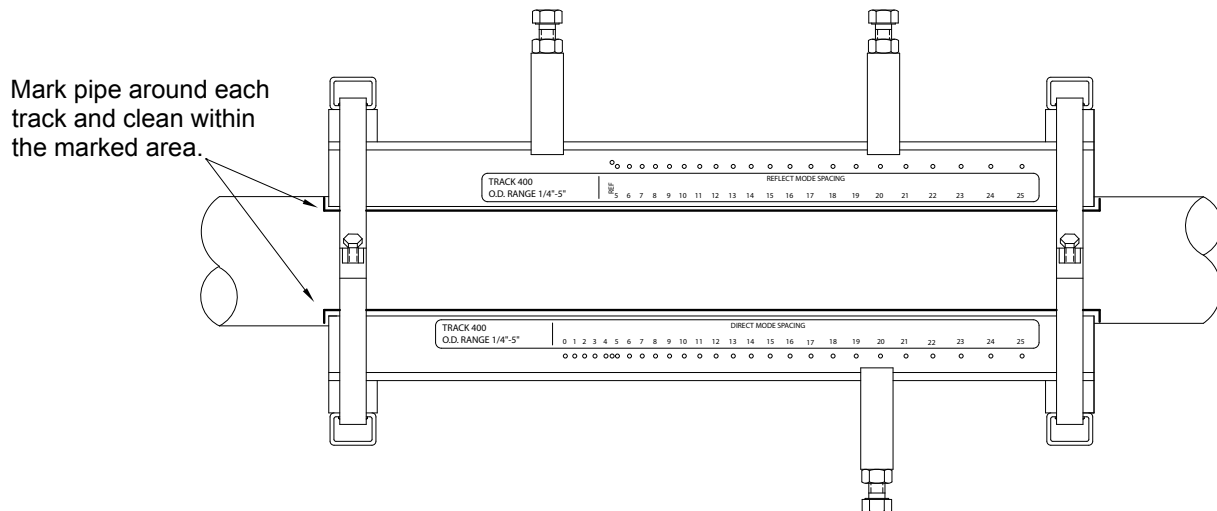

3. Re-install the two track mount hardware assemblies on the pipe and loosely secure them in place with the mounting straps provided. Align the assemblies such that they are positioned on top of the cleaned surfaces.

4. Wrap the Mylar spacing guide around the pipe placing it against the end of the track mount assemblies. Ensure that it is snug around the pipe and mark along the overlapping edge.

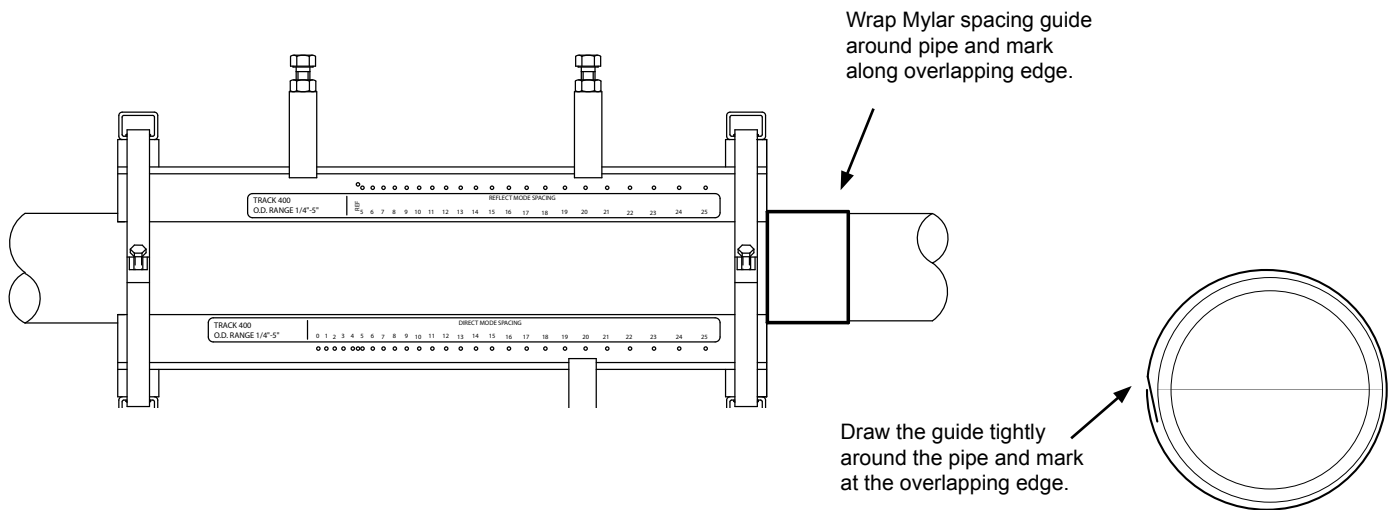

5. Remove Mylar spacing guide and lay it out on a flat surface. Either measure the exact distance half-way between the overlap edge and the mark at the overlap, or fold the guide from the overlap edge to overlap mark and draw a line at the fold or halfway point.

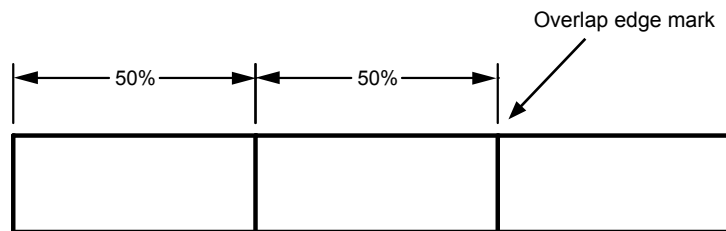

6. Reinstall the spacing guide and tape it in place. Use the edge of the guide to align each assembly bracket as shown.
7. Rotate the track assemblies until the center of one track aligns with the center line on the spacer guide, and the center of the other track aligns at the point where the spacer guide ends meet. The tracks should now be 180° apart. Tighten both mounting straps to secure the assembly to the pipe. Do not over tighten.

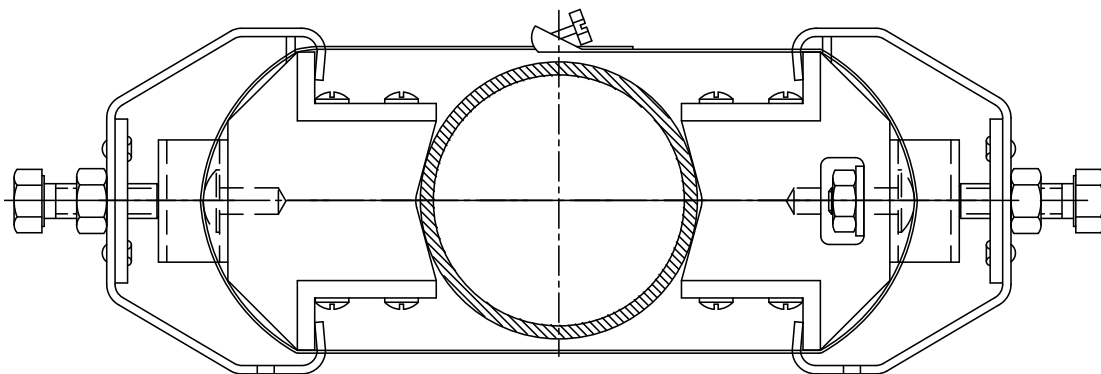

### 3.3.7 Installing Transducers In Bracket and Spacer Bar Hardware

1. Apply the dry coupling pad to the transducer as show below.

Apply a continuous lengthwise 1/2" wide bead of coupling compound down the center of the transducer.

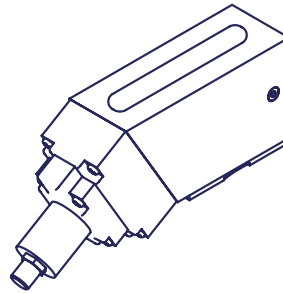

2. This step only applies to reflect mount transducers installed on copper and steel pipes. For all other applications, skip to step 3.

Apply the dry coupling pad to the transducer as show below.

Place the dry coupling pad on the transducer. Gently press down just enough to seat and center the pad.

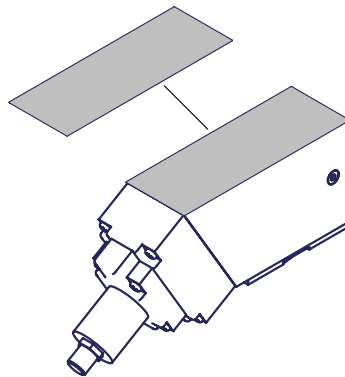

Apply a second bead of coupling compound down the center of the dry coupling pad.

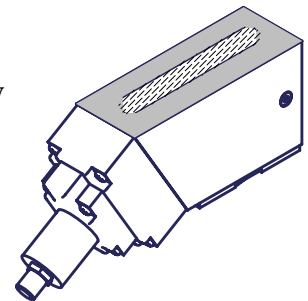

3. Slide the transducer into the mounting bracket back end first, aligning the angled edge of the transducer with the angled edge of the bracket. Do not allow the bottom of the transducer to make contact with the pipe until it butts against the mounting bracket stop. Push down firmly on the transducer to mate with pipe.

When installing the transducer, do not allow the bottom face to touch the pipe surface until it is fully inserted to the stop.

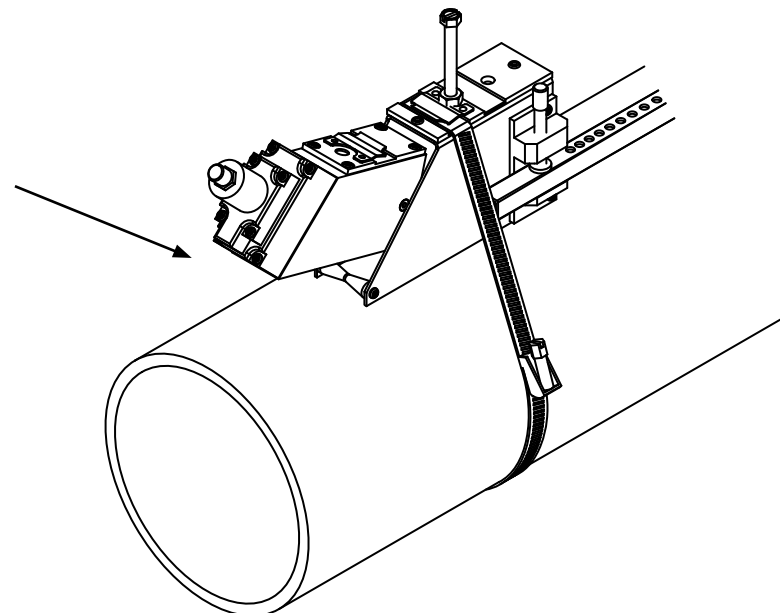

- Tighten the transducer clamping screw to hold the transducer firmly in place. Do not over tighten the screw.

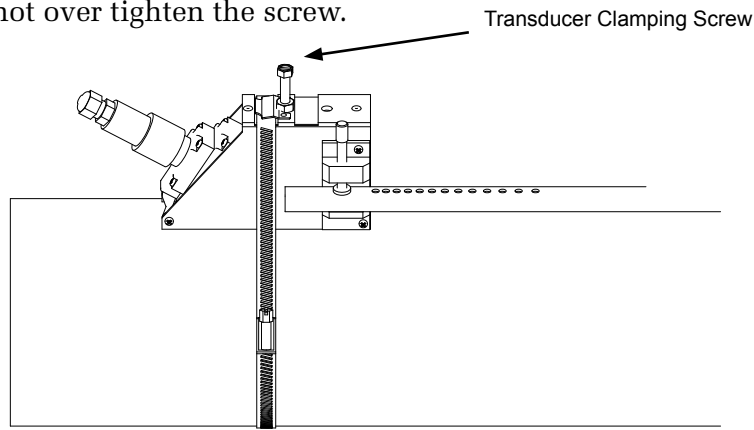

- Repeat procedure for the second transducer.

### 3.3.8 Installing Transducers In Track Mount Hardware

- Insert the index pin into the reference hole.

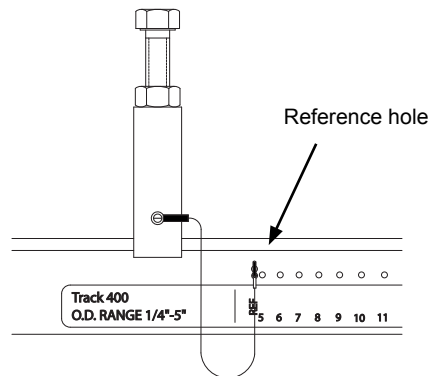

- Repeat step 1 and 2 in Section 3.3.7 as necessary to apply couplant and pad to transducer.
- Place the transducer between the track rails, slightly behind the pin and under the clamping screw assembly. Slide it forward until it butts firmly against the reference pin. Once the transducer is in place, secure it with the sensor clamping screw. Do not over tighten.

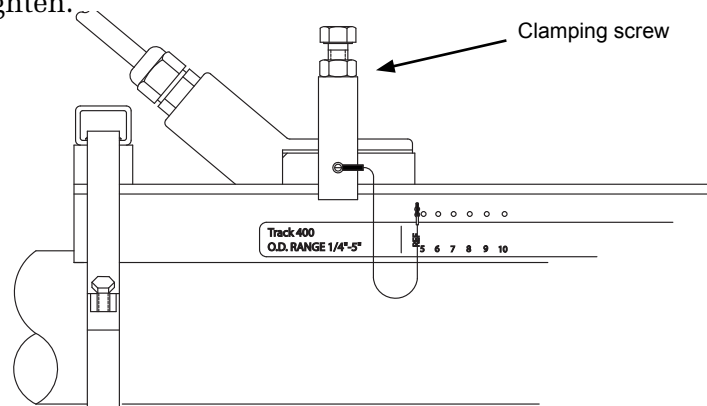

- Repeat procedure for the second transducer.

### 3.4 CONNECTING THE TRANSDUCER SIGNAL CABLES

ONICON F-4000 transducer cables are special purpose coaxial cables. Care must be taken when installing the cables to ensure that electrical noise will not affect the performance of the meter. The cables must NOT be bundled or run in conduit with any other signal or power cables. The maximum allowable cable length is 300 ft.

To install the cables, first locate and install the wall-mount electronics enclosure and the transducers.

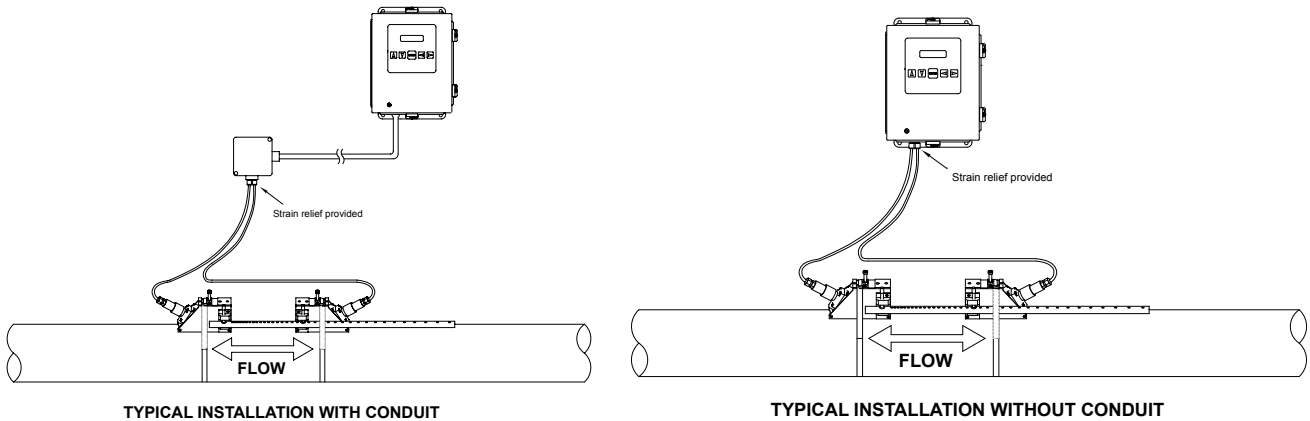

The transducer cables are provided with connectors already installed at one end of the cable. Install this end of each cable at the electronics enclosure as shown below using the right angle adapters provided. When installing the cable, avoid routing it close to strong sources of electrical noise, and do not install cables in raceways with power or other signal cables.

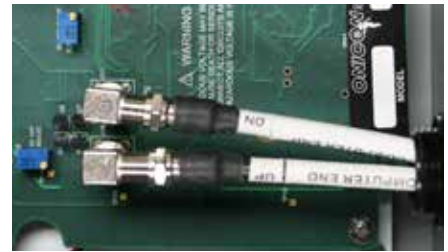

Once the correct cable length has been determined, install the F-connectors provided to terminate the end of each cable.



#### WARNING

For proper operation, cables must not be bundled or run in conduit with any other signal or power cables.

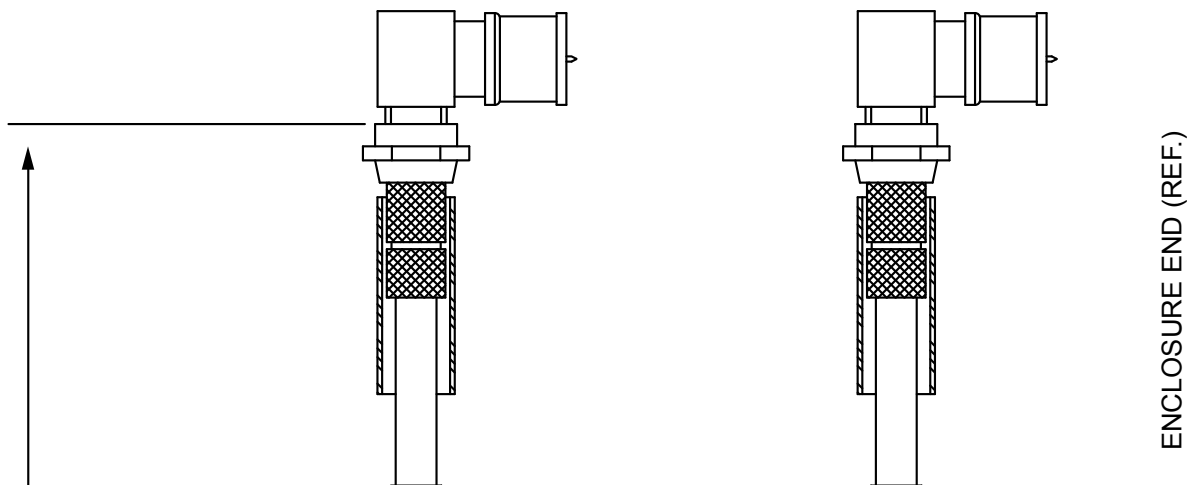



## 3.5 INSTALLING THE F-CONNECTORS

Prior to installing the F-connectors, slide the upstream and downstream cable markers over the ends of the cables followed by the strain relief and NPT adapters.

### 3.5.1 Cable Preparation

Strip and trim to length as shown. Do not push copper braid back over jacket.

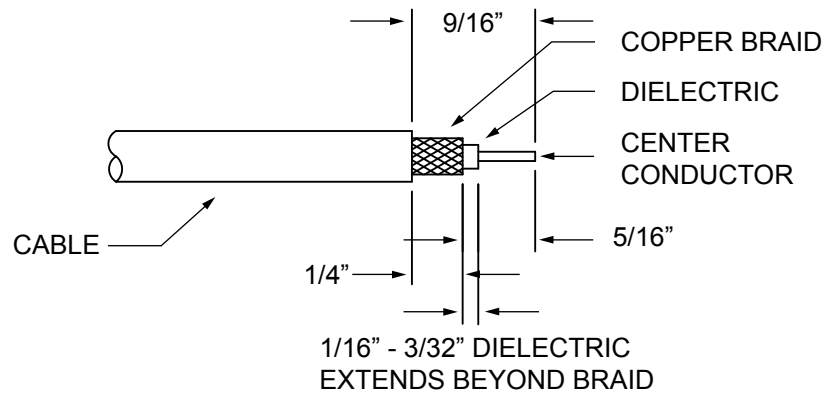

### 3.5.2 Cable & Connector Assembly

Thread cable into connector until the dielectric slightly protrudes from the end of the barrel. The center conductor should protrude approximately 1/16" beyond the connector body as shown.

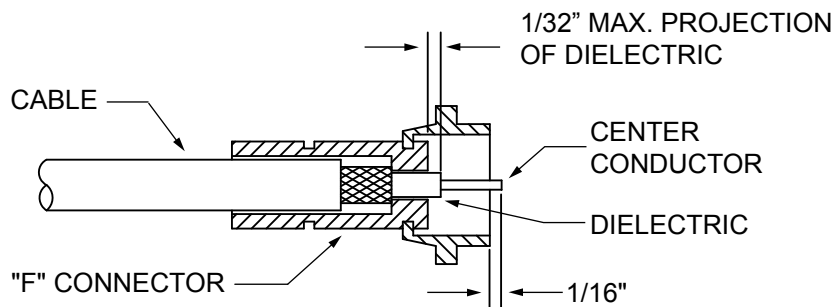

### 3.5.3 Final Assembly

Place shrink tubing over the connector and shrink in place with hot air gun.

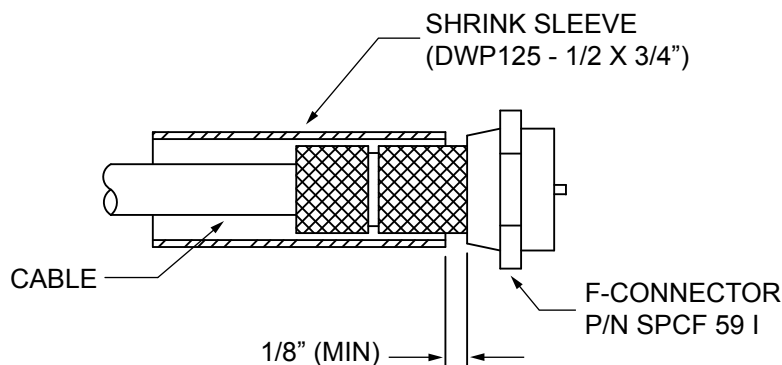

## 3.6 ELECTRICAL INSTALLATION

All user supplied conduit fittings, junction boxes, etc. must be installed in compliance with federal, state and local building codes.

### 3.6.1 Input Power Options

The F-4000 can be ordered with two different input voltage options. This is not user selectable in the field. The input power options are:

11.5 - 28.5 VDC, 10 Watts maximum  
90 - 240 VAC 50/60 Hz, 15 VA maximum



#### WARNING

Conduit openings in the F-4000 enclosure must be closed with UL listed fittings applicable to NEMA 4 enclosures.



#### WARNING

The protective earth connection must be made as shown in Section 3.6.2. Failure to do so will result in an increased risk of injury.



#### WARNING

All mains voltage connections must be made through the pre-drilled conduit/strain relief opening located at the bottom of the enclosure. Failure to do so will result in an increased risk of injury.



#### CAUTION

This product must be connected to earth ground for proper operation. Failure to do so may result in erratic operation.

### 3.6.2 Electrical Connections



#### WARNING

Turn off mains power at the source prior to making power connections to the F-4000. Contact with exposed live wiring may result in electric shock, burns and/or serious injury.

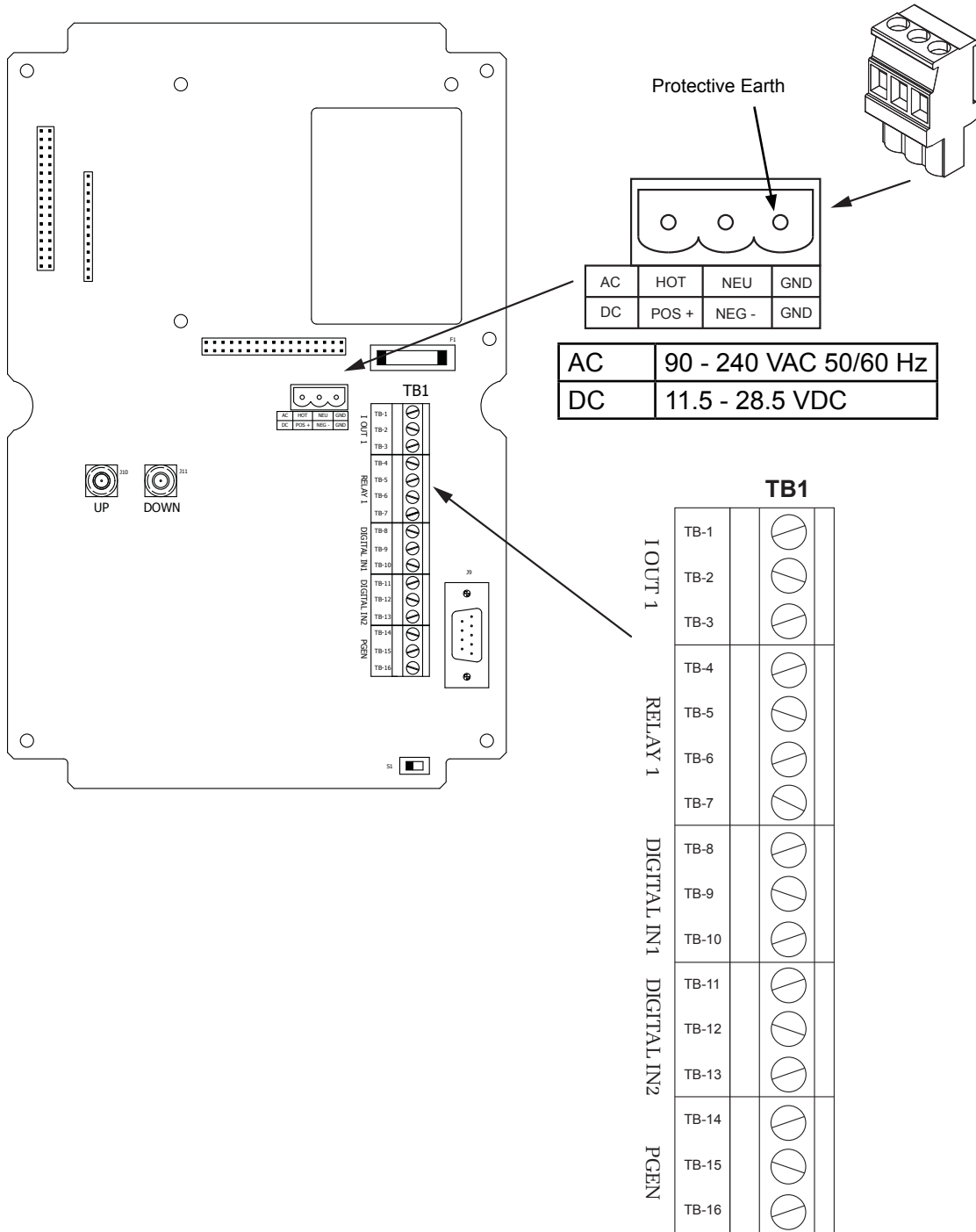

See the table on the next page for text block 1 wiring connections.

Analog Output (IO1)			
Term #	Function	Description	
1	(+) 4 - 20 loop supply	Loop (externally) powered 4 - 20 mA output	
2	(-) 4 - 20 loop return		
3	Shield		
RL=250 Ω typical, 750 Ω maximum			
Vc=24 VDC typical / 30 VDC maximum			

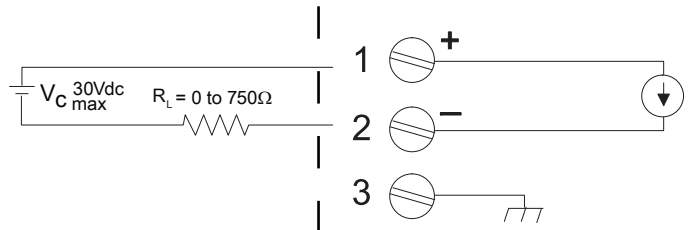

Relay Output (RELAY OUTPUT)			
Term #	Function	Description	
4	Common	Relay Common	
5	Normally Open	Relay Output	
6	Normally Closed	Relay Output	
7	Shield		
RL=300 Ω minimum			

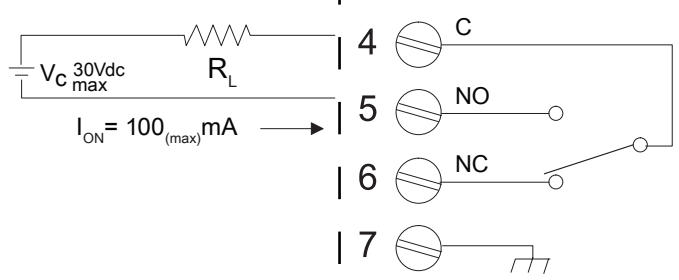

Digital Inputs (NO TOT, CLR TOT)			
Term #	Function	Description	
8	(+) No Totalizer	Digital input used to inhibit totalizer	
9	(-) No Totalizer		
10	Shield		
11	(+) Reset Totalizer	Digital input used to reset totalizer to zero	
12	(-) Reset Totalizer		
13	Shield		
Vc=2-10VDC; Then RL=0Ω			
Vc=>10≤30VDC; Then RL=(Vc-10)/.02			

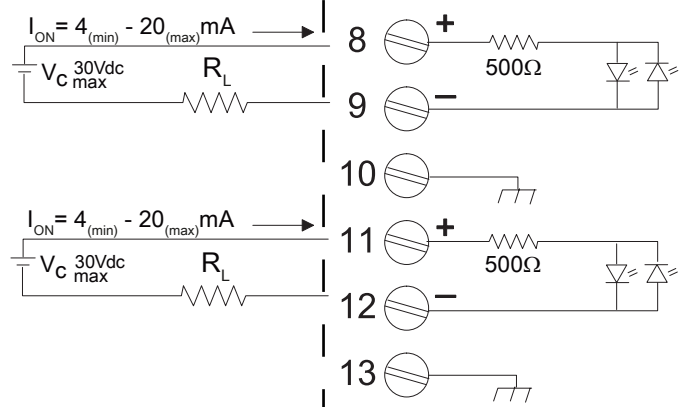

Pulse Output (PULSE OUTPUT)			
Term#	Function	Description	
14	(+) Pulse Output	Programmable pulse output. Optically isolated (externally powered) open collector.	
15	(-) Pulse Output		
16	Shield		
Vc= +30 VDC maximum			
RL = 3K Ω minimum			

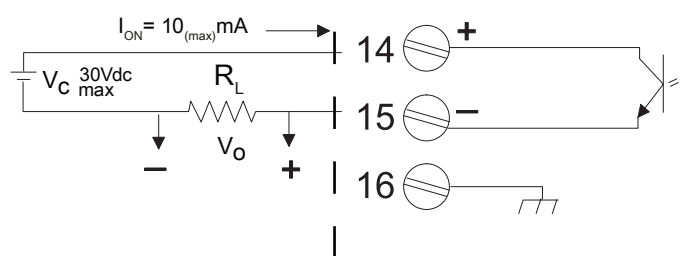

## SECTION 4.0: START-UP

Each time an F-4000 flow meter is installed on a pipe, a new installation “site” must be created or an existing site must be recalled from memory. An installation “site” contains all of the operating parameters required to configure the meter for one specific installation. If it does not exist, it must be created before the meter can measure flow.

ONICON F-4000 flow meters are normally shipped with the intended installation site pre-programmed into the memory of the meter. This pre-programmed site was created and stored in the memory at the ONICON factory and is based on installation data provided to ONICON when the meter was ordered. The information programmed into the site is also provided in a document that accompanies the installation hardware. It is titled, “Site Installation Details”.

If the information contained in the Site Installation Details document matches that specific installation location, then the stored site can be recalled as per section 4.2 below. If there is any discrepancy, the site must be edited and resaved before it is used. Contact ONICON for assistance in editing or creating a new site.

Once a site has been recalled and loaded into active memory, the transducers can be activated by using the “Install” function. During this process the meter will automatically select the optimum operating frequency and establish a speed of sound reading for the fluid in the pipe. Depending on the pipe material and the operating mode (reflect or direct) the meter may also adjust for any zero offsets and set the level for the empty pipe detector.

### 4.1 PROGRAM MODE KEYPAD FUNCTIONS

#### Keypad Pushbuttons



Enter program mode or save selected option or numeric entry.



Right enters menu function or moves down to lower level menu.  
Left exits menu function or moves up to higher menu level.



Used to scroll up and down through menu or option lists.

#### IMPORTANT NOTE

When powering the meter for the first time, a splash screen message may scroll across the display. This will only happen when no site is installed.

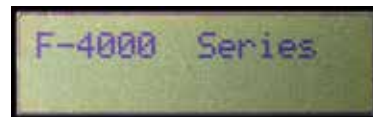
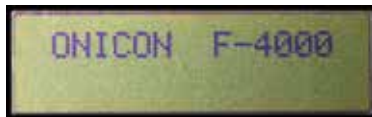

## 4.2 RECALLING A SAVED SITE

If this is the first time the meter is installed, confirm that the site to be recalled matches the actual installation as described above. This can be done by reviewing the Site Installations Detail document provided with the meter.











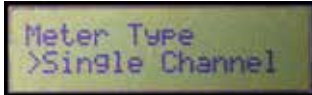

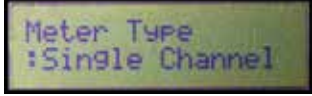

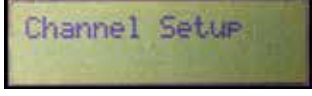

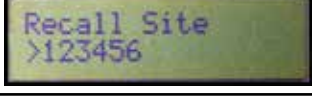
The procedure below is used to recall a saved site and load it into active memory. Recalling a site will automatically over write any previously loaded site.

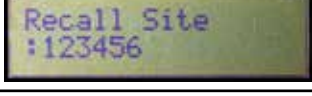

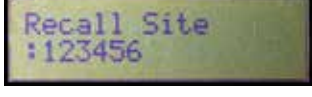
### IMPORTANT NOTE

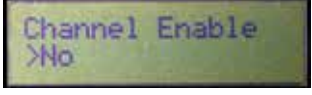
Choose the appropriate site from those listed. The site created at the ONICON factory is the serial number of the meter. “Z” sites are factory defaults, and should not be used without first consulting ONICON technical service.

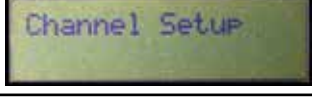
If at any time you wish to return to the beginning of this procedure, press  repeatedly until you arrive at Step#1.

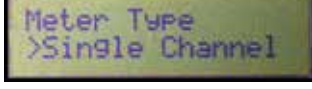
Step	Press the Following Keypad Pushbutton	Displayed Information (After Keypress)	Comment
1.			
2.			
3.			
4.			
5.			
6.	 (Press as necessary)		Choose the appropriate site from those listed. The correct site is the serial number of the meter. “Z” sites are factory defaults, and should not be used.
7.			
8.			
9.			

## 4.3 INSTALLING RECALLED SITES











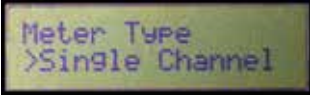

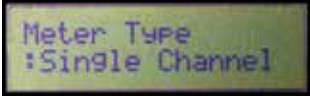

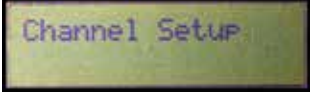

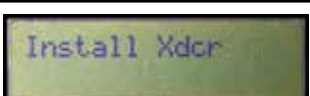
When you “Install” a site, you activate the transducers so the meter can read flow. During this process, the meter will select the best operating frequency and establish baseline operating parameters such as the speed of sound reading in meters/second.

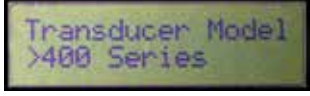
There are two different procedures for installing a site. One procedure is for transducers mounted in the reflect mode on steel or copper pipe. The other is for transducers mounted in the direct mode. The two procedures are detailed below.

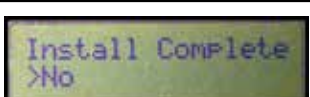

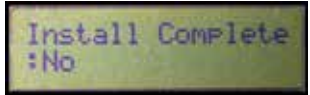

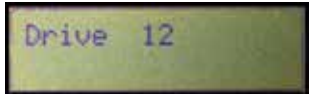

### 4.3.1 Reflect Mount Installations

Follow the specific instructions below to complete the installation of the meter in reflect mount mode. If your meter is installed in direct mount mode, advance to section 4.2.2.

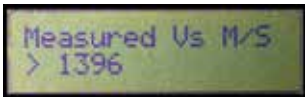

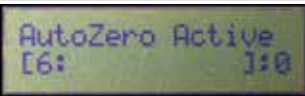







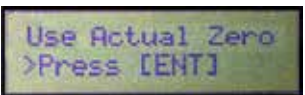

If at any time you wish to return to the beginning of this procedure, press  repeatedly until you arrive at Step#1.

Step	Press the Following Keypad Pushbutton	Displayed Information (After Keypress)	Comment
1.			
2.			
3.			
4.	 (Press 3 times)		
5.			Your transducer model and size may be different. Consult the Site Installation Details form for the exact series and size.
6.	 (Press 3 times)		
7.			
8.			
9.			Display will cycle through drives as the initial installation is completed. Wait for this to complete.

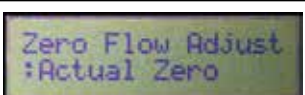
It is possible that the meter will display a message other than the speed of sound. Section 6 in this manual describes these messages and how to resolve them. Please contact ONICON with questions or concerns.

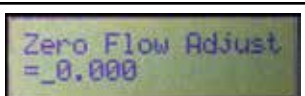
10.	None		Displays the measured speed of sound. This number should closely approximate the speed of sound listed on the Site Installation Details document.
11.			AutoZero is checking and correcting for any zero offset. Wait for this to complete.
If a “Use Actual Zero” message appears when installing a meter on a copper tube, follow the instructions provided at the end of this table to complete the installation.			
12.	None		MTYmatic is the default empty pipe detection setting.
13.			You are no longer in the program mode. The meter is now measuring flow. Run mode menus are described in section 4.4.

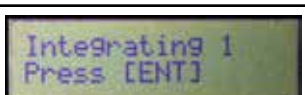
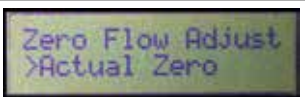
### Alternate Procedure for Zeroing Flow When Installing Meter on Copper Tube

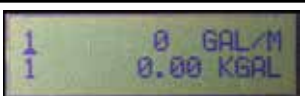









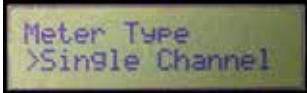

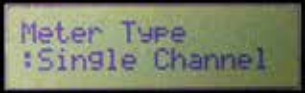

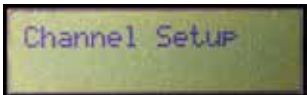

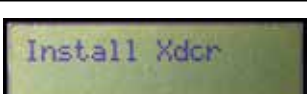

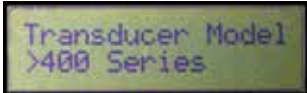

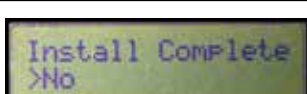

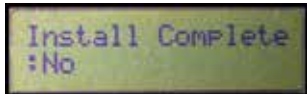
1.	None		Follow the procedure outlined below if the AutoZero failed to activate on copper tubing.
2.			MTYmatic is the default empty pipe detection setting.
Complete the following steps only if flow can be stopped in the pipe. If not, skip to the last step in this table.			
3.			
4.			Enter Zero Flow Adjust. Use Up/Down keys as necessary to select Actual Zero.
5.			
6.			Display will integrate zero flow for 60 seconds, do not hit enter until complete.
7.	None		Zero flow integration complete.
8.			You are no longer in the program mode. The meter is now measuring flow.

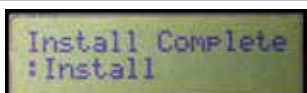

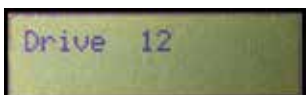

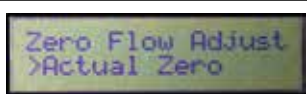

### 4.3.2 Direct Mount installations

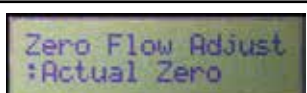
Follow the specific instructions below to complete the installation of the meter in direct mount mode.

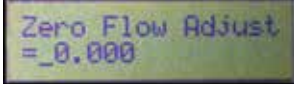

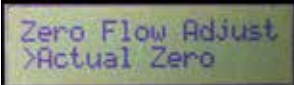
If at any time you wish to return to the beginning of this procedure, press  repeatedly until you arrive at Step#1.

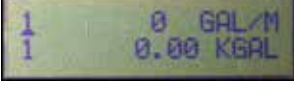
Step	Press the Following Keypad Pushbutton	Displayed Information (After Keypress)	Comment
1.			
2.			
3.			
4.	 (Press 3 times)		
5.			Your transducer model and size may be different. Consult the Site Installation Details form for the exact series and size.
6.	 (Press 3 times)		
7.			
8.			
9.			Display will cycle through drives as the initial installation is completed. Wait for this to complete.
It is possible that the meter will display a message other than the speed of sound. Section 6 in this manual describes these messages and how to resolve them. Please contact ONICON with questions or concerns.			
10.	None		Displays the measured speed of sound. This number should closely approximate the speed of sound listed on the Site Installation Details document.
Complete the following steps only if flow can be stopped in the pipe. If not, skip to the last step in this table.			
11.			MTYmatic is the default empty pipe detection setting.
12.			
13.			Enter Zero Flow Adjust. Use Up/Down keys as necessary to select Actual Zero.

14.			
15.			Display will integrate zero flow for 60 seconds, do not hit enter until complete.
16.	None		Zero flow integration complete.
17.			You are no longer in the program mode. The meter is now measuring flow.

#### 4.4 NAVIGATING THE RUN MODE MENU PAGES

The display contains two lines of alphanumeric characters. Each line can be independently set to display any of the seven operating parameters listed below.

Keypad Pushbuttons	Description of functions in run mode
	Not used in run mode.
	Right arrow activates cursor below left most character on the display. The cursor must be active and visible before you can change the displayed data. Left arrow not used.
	Used to scroll up and down through the display menu options.

Flow Rate – displays the current instantaneous flow value (e.g. 20.3 GAL/M). Note that reverse flow is indicated by a minus sign preceding the displayed value (e.g. – 20.3 GAL/M).



Flow Total – displays the current flow total (e.g. 15030.5 GAL) Note: flow multipliers can be kilo (K) or mega (M). The resolution of the displayed total can be set to show 1 – 3 digits to the right of the decimal point. Totalizer will roll over to zero when the maximum count is exceeded.



Gain Level Percentage (Valc) – displays the signal amplifier gain level as a percentage value. The higher the Valc value, the better. Valc values greater than 30 are generally considered good.



Aeration Percentage (Vaer) - displays the noise level generally associated with entrained air as a percentage value. Lower values indicate less entrained air.



Signal Strength (mV) - displays the actual signal level in millivolts. Higher signal levels indicate a good sonic coupling.



Speed of Sound (M/S)- displays the current speed of sound of the fluid in meters/second.



Operating Status (-----) displays the current status of alarm messages. The table below briefly describes the one letter code for each message.

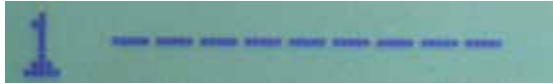

Letter	Alarm Message
S	Spacing - indicates a problem with the spacing of the transducers.
Z	Zero - indicates a fault with the zeroing function.
E	Empty - indicates that the empty pipe alarm is active.
R	Rate - indicates a flow rate above or below the maximum or minimum alarm levels.
F	Fault - indicates three continuous seconds without a new data update.
A	Aeration - indicates excessive amounts of entrained air in the flow stream.
M	Memory - last valid reading for a selected interval during a fault condition.
K	Make-up - indicates an in-process make-up occurred.
I	Interface - indicates the maximum speed of sound alarm set-point was exceeded.

## **SECTION 5.0: COMMISSIONING FOR ONICON CLAMP-ON ULTRASONIC FLOW METERS**

Please read all installation instructions carefully before proceeding. Wiring diagrams are located in an earlier section of this manual. Use the meter certificate of calibration to verify that the specified installation & operating parameters match the actual conditions at the location where the meter is installed. A worksheet for checking off these steps and recording measured values is located in section 5.3.

### **5.1 HELPFUL HINTS FOR START-UP AND COMMISSIONING**

Please read these helpful hints before proceeding with the commissioning procedure on the next page.

1. ONICON flow meters are individually calibrated for a particular application. Be sure to verify the pipe size and location.
2. The ultrasonic flow sensing systems will not work with an empty pipe.
3. When measuring analog output signals, remember that current (mA) must be measured in series, while voltage is measured in parallel. If the 4-20 mA signal is already connected to a control system, you must break the connection and measure the signal in series.
4. When measuring frequency outputs in Hz, take your multimeter out of “auto range mode” and manually set the range for a voltage level above 15 VDC. This will prevent false readings when signal is not present.

## 5.2 COMMISSIONING PROCEDURE

Please read the entire procedure before proceeding. A worksheet for checking off the following steps and recording measured values provided in Section 5.3.

1.	Confirm that the flow meter is being installed in accordance with Sections 1.8 and 3.2 of this manual.	Confirm that the installation location is removed from any sources of strong electrical interference and that the enclosure is mounted on a vibration-free surface. Confirm that the transducer signal cables are run in dedicated conduit without other signal or power cables.
2.	Confirm flow meter location.	Confirm adequate straight pipe run to achieve desired results. Is the meter located in the correct location as required by the plans? Compare actual straight pipe upstream and downstream of the meter location to recommended distances identified in this manual. Contact ONICON to discuss specifics of your application. If straight pipe run is very short, consult ONICON PRIOR to commissioning the meter.
3.	Confirm pipe size.	Confirm that the meter is tagged for the pipe size in which it is installed. When in doubt, measure the circumference of the pipe. Pipe O.D. = (circumference / 3.14) – (insulation thickness x 2).
4.	Verify the type of fluid used in the piping system.	Confirm that the fluid specified on the flow meter certificate of calibration matches the fluid flowing in the piping system.
5.	Confirm control system programming.	Confirm that the control system input points are properly configured for the analog output range, pulse scale factor and/or relay output function identified on the calibration certificate & meter tag.
6.	Confirm connection to the correct ONICON display or Btu meter (if ordered).	Confirm that the flow meter serial number matches the ONICON display or Btu meter serial number (when ordered together).
7.	Verify output signal wiring.	Verify that the wiring is correct as shown in this manual and/or the additional wiring diagram provided with the ONICON display or Btu meter. If in doubt, contact ONICON for assistance before proceeding further.
8.	Confirm correct supply voltage.	Verify that the supply voltage is within specified limits. 11.5 – 28.5 VDC or 90 – 240 VAC 50/60Hz
The following steps require flow in the pipe. Flow signal readings should be taken while holding the flow rate constant, if possible. Otherwise, take the various output readings as quickly as possible.		
9.	Record the information shown on the flow meter display.	Record readings shown for: Flow rate Flow total Valc – automatic gain setting Vaer – aeration level mV – signal strength M/S – speed of sound(Vs) Operating status (-----)
10.	Measure and record analog or pulse outputs.  Current Output:  Scaled Relay Output:	Refer to flow meter wiring diagram for the various outputs based on your particular installation. Use the following formulas to calculate flow rate from measured analog signals:  GPM = $\frac{\text{measured current in mA} - 4}{16} \times \text{Full Scale Analog Flow Rate}$  Each contact closure = unit volume identified as “Scale Factor” (.Measure and record time interval between contact closures.)
11.	Compare various output signals to each other and to the flow rate displayed by the control system.	Compare the flow rate calculated in step 10 to meter display and to the flow rate indicated by the control system. Refer to the troubleshooting section of this manual when readings are inconsistent.
End of standard commissioning. Please contact ONICON at (727) 447-6140 with any questions.		

### 5.3 COMMISSIONING WORKSHEET

Please read all installation instructions carefully prior to proceeding with these steps. Use the following worksheet for checking off the commissioning steps and recording measured values. The following steps require flow in the pipe. Flow signal readings should be taken while holding the flow rate constant, if possible. Otherwise, take the various output readings as quickly as possible.

STEP	TEST/MEASUREMENT	S/N:	S/N:	S/N:	S/N:
1.	Site selection/ location OK:				
2.	Straight run OK:				
3.	Measured pipe size:				
4.	Record fluid type:				
5.	Control system programming OK:				
6.	Record Btu meter / display S/N:				
7.	Signal & transducer wiring Ok:				
8.	Record measured supply voltage:				
9.	Record the displayed data:	Rate _____ Total _____ Valc _____ Vaer _____ mV _____ Vs _____ Status _____	Rate _____ Total _____ Valc _____ Vaer _____ mV _____ Vs _____ Status _____	Rate _____ Total _____ Valc _____ Vaer _____ mV _____ Vs _____ Status _____	Rate _____ Total _____ Valc _____ Vaer _____ mV _____ Vs _____ Status _____
10.	Analog or pulse output(s) 4-20 mA signal: Scaled output interval: Calculated flow rate:	_____ mA _____ VDC _____ GPM	_____ mA _____ VDC _____ GPM	_____ mA _____ VDC _____ GPM	_____ mA _____ VDC _____ GPM
11.	Flow rate displayed by control system.	_____ GPM	_____ GPM	_____ GPM	_____ GPM

## SECTION 6.0: TROUBLESHOOTING

DISPLAYED MESSAGE	POSSIBLE SOLUTIONS
Blank display and power light off	<ul style="list-style-type: none"> <li>• Verify that the supply voltage to the flow meter is present.</li> <li>• Check the fuse. If the fuse is open, contact ONICON for assistance.</li> </ul>
Low Signal - Press <ENTER>	<p>During the initial site installation, the flow meter detects signal levels that are insufficient for proper operation. Some reasons for low signal are:</p> <ul style="list-style-type: none"> <li>• Invoking [Install completed?] on an empty pipe.</li> <li>• Coupling compound and pad not applied or improperly applied. Coupling compound evaporated.</li> <li>• A disconnected or broken sensor cable.</li> <li>• The pipe surface needs to be cleaned at the mouting location.</li> <li>• Flush out large air bubbles from the piping system.</li> <li>• The sensor cables are defective or not connected to the correct channel.</li> <li>• The Set Empty routine was performed when pipe was NOT actually empty.</li> </ul> <p>If you locate and correct the improper condition immediately, press &lt;ENTER&gt; to resume the installation procedure. Otherwise, press the &lt;Left Arrow&gt; to abort the installation and conduct a thorough investigation. Contact ONICON for assistance.</p>
Detection Fault	<p>During the initial site installation, the flow meter detects signal levels that are insufficient for proper operation. See “Low Signal” above for possible remedies. Contact ONICON if attempts to resolve the problem fail.</p>
Invalid Set-up (use direct mode)	<p>During the initial site installation, the system detects invalid sensor spacing, a liquid type different than expected, pipe dimensions different than expected, or some other factor that prevents it from completing the installation. This may be due to one of the following:</p> <ul style="list-style-type: none"> <li>• The pipe material, outside diameter or wall thickness does not match the selections programmed into the meter and listed on the site installation details document.</li> <li>• The transducer spacing is incorrect. Re-confirm the transducer spacing matches the information provided in the site installation details document.</li> <li>• Contact ONICON for assistance.</li> </ul>
Re-space Index	<p>Upon measuring the liquid sonic velocity (Vs), the meter recommends re-spacing the sensors to improve performance. Change spacing as directed and re-install site. Contact ONICON if the problem persists.</p>
No Sites - Press <ENTER>	<p>Response while trying to recall/delete a site set-up when no sites are stored.</p>
Chan Not Set Up	<p>Response to an attempt to invoke an operation that requires a channel to be enabled. A channel cannot be enabled until its sensors are operating. Install transducers and re-try installation.</p>
Empty Pipe - Press <ENTER>	<p>Prompt to empty the pipe during the Actual MTY procedure. After emptying the pipe, press &lt;ENTER&gt;.</p>
Fill Pipe - Press <ENTER>	<p>Prompt to fill the pipe during the Actual MTY procedure. After filling the pipe, press &lt;ENTER&gt;.</p>
<EOT>	<p>Response to a request to output data logger data to the printer or the graphics screen when no data logger data exists. Set up the data logger.</p>
Memory Full!	<p>Response to an attempt to save site data when data memory is full. Delete an obsolete site or clear data logger memory to make room for new data.</p>
Memory Corrupted!	<p>Memory read error occurred while accessing the active site data. Contact ONICON for assistance.</p>

# SONIC VELOCITY RELATIVE TO TEMPERATURE OF PURE WATER



Sonic Velocity Relative to Temperature of Pure Water								
Temperature		Velocity	Temperature		Velocity	Temperature		Velocity
°F	°C	M/S	°F	°C	M/S	°F	°C	M/S
0.0	-17.8	1292.45	100.0	37.8	1525.03	200.0	93.3	1548.38
2.0	-16.67	1300.64	102.0	38.9	1526.99	202.0	94.4	1547.60
4.0	-15.55	1308.63	104.0	40.0	1528.86	204.0	95.6	1546.78
6.0	-14.44	1316.44	106.0	41.1	1530.67	206.0	96.7	1547.60
8.0	-13.33	1324.06	108.0	42.2	1532.4	208.0	97.8	1545.02
10.0	-12.22	1331.50	110.0	43.3	1534.06	210.0	98.9	1544.08
12.0	-11.00	1338.77	112.0	44.4	1535.64	212.0	100.0	1543.11
14.0	-10.0	1345.86	114.0	45.6	1537.16	214.0	101.1	1542.10
16.0	-8.89	1352.78	116.0	46.7	1538.61	216.0	102.2	1541.05
18.0	-7.78	1359.53	118.0	47.8	1539.99	218.0	103.3	1539.97
20.0	-6.67	1366.12	120.0	48.9	1541.30	220.0	104.4	1538.85
22.0	-5.56	1372.55	122.0	50.0	1542.55	222.0	105.6	1537.70
24.0	-4.44	1378.82	124.0	51.1	1543.74	224.0	106.7	1536.51
26.8	-3.33	1384.94	126.0	52.2	1544.86	226.0	107.8	1535.29
28.0	-2.22	1390.90	128.0	53.3	1545.91	228.0	108.9	1534.03
30.0	-1.11	1396.72	130.0	54.4	1546.91	230.0	110.0	1532.74
32.0	0.0	1402.39	132.0	55.6	1547.84	232.0	111.1	1531.42
34.0	1.11	1407.91	134.0	56.7	1548.72	234.0	112.2	1530.06
36.0	2.22	1413.30	136.0	57.8	1549.53	236.0	113.3	1528.67
38.0	3.33	1418.55	138.0	58.9	1550.29	238.0	114.4	1527.26
40.0	4.44	1423.66	140.0	60.0	1550.99	240.0	115.6	1525.81
42.0	5.56	1428.64	142.0	61.1	1551.63	242.0	116.7	1524.33
44.0	6.67	1433.48	144.0	62.2	1552.21	244.0	117.8	1522.83
46.0	7.78	1438.20	146.0	63.3	1552.74	246.0	118.9	1521.29
48.0	8.89	1442.80	148.0	64.4	1553.22	248.0	120.0	1519.73
50.0	10.0	1447.27	150.0	65.6	1553.64	250.0	121.1	1518.14
52.0	11.11	1451.62	152.0	66.7	1554.01	260.0	126.7	1507.00
54.0	12.22	1455.85	154.0	67.8	1554.32	270.0	132.2	1497.00
56.0	13.33	1459.97	156.0	68.9	1554.59	280.0	137.8	1487.00
58.0	14.44	1463.97	158.0	70.0	1554.80	290.0	143.3	1476.00
60.0	15.56	1467.86	160.0	71.1	1554.98	300.0	148.9	1465.00
62.0	16.67	1471.64	162.0	72.2	1555.07	310.0	154.4	1453.00
64.0	17.79	1475.31	164.0	73.3	1555.13	320.0	160.0	1440.00
66.0	18.89	1478.88	166.0	74.4	1555.15	330.0	165.6	1426.00
68.0	20.0	1482.34	168.0	75.6	1555.11	340.0	171.1	1412.00
70.0	21.1	1485.70	170.0	76.7	1555.03	350.0	176.7	1398.00
72.0	22.2	1488.96	172.0	77.8	1554.90	360.0	182.2	1383.00
74.0	23.3	1492.13	174.0	78.9	1554.72	370.0	187.8	1368.00
76.0	24.4	1495.19	176.0	80.0	1554.49	380.0	193.3	1353.00
78.0	25.6	1498.16	178.0	81.1	1554.22	390.0	198.9	1337.00
80.0	26.7	1501.04	180.0	82.2	1553.91	400.0	204.4	1320.00
82.0	27.8	1503.82	182.0	83.3	1553.55	410.0	210.0	1302.00
84.0	28.9	1506.52	184.0	84.4	1553.14	420.0	215.6	1283.00
86.0	30.0	1509.13	186.0	85.6	1552.70	430.0	221.1	1264.00
88.0	31.1	1511.65	188.0	86.7	1552.21	440.0	226.7	1244.00
90.0	32.2	1514.08	190.0	87.8	1551.67	450.0	232.2	1220.00
92.0	33.3	1516.44	192.0	88.9	1551.10	460.0	237.8	1200.00
94.0	34.4	1518.70	194.0	90.0	1550.48	470.0	243.3	1180.00
96.0	35.6	1520.89	196.0	91.1	1549.82	480.0	248.9	1160.00
98.0	36.7	1523.00	198.0	92.2	1549.12	490.0	254.4	1140.00

# F-4000 SERIES MOTHER BOARD





## CONDITIONS OF SALE

1. **ACCEPTANCE:** The following Conditions of Sale apply to all sales of ONICON's products. These provisions shall apply even if ONICON fails to object to provisions appearing on, incorporated by, referenced in, or attached to Buyer's purchase order form. Buyer's acceptance of delivery of ONICON's products constitutes its acceptance of these Conditions of Sale.
2. **DELIVERY AND TITLE:** All product shipments are F.O.B. shipping point and title passes to the Buyer at the time ONICON delivers the merchandise to the carrier. Risk of loss or damage to the product passes to the Buyer at the time ONICON delivers the product to the carrier. The Buyer immediately upon receipt should inspect all shipments, and should there be any evidence of damage or loss in transit, Buyer must file claims or tracers upon carrier. ONICON will assist in tracing shipments upon request.
3. **LIMITED WARRANTY:** ONICON warrants that for a period of two (2) years following the date of original shipment of an ONICON product: (i) the product will conform to ONICON's standard written specifications applicable to such product in effect on the date of Buyer's order, or as modified by ONICON's quotation or Buyer's purchase order accepted by ONICON, (ii) the product will be free from defects in workmanship, and (iii) that ONICON has title to the product prior to shipment to the Buyer; provided, however, that the warranties provided herein shall be void and may not apply in the event Buyer misuses or damages a product, including, but not limited to, any use by the Buyer of a product for an application other than one of a type approved by ONICON. ONICON's sole liability and Buyer's sole remedy for any breach of the foregoing warranty is for ONICON to repair or replace, at ONICON's option, any defective product that is returned to ONICON during the warranty period. EXCEPT AS MAY BE SPECIFICALLY AGREED BY ONICON IN WRITING IN RELATION TO EACH SALE, NO OTHER WARRANTIES SHALL APPLY, WHETHER EXPRESSED, IMPLIED OR STATUTORY, AND THERE SHALL BE NO IMPLIED WARRANTIES OF MERCHANTABILITY AND FITNESS FOR A PARTICULAR PURPOSE.
4. **REMEDIES:** ONICON'S OBLIGATION UNDER THE FOREGOING WARRANTIES IS LIMITED SOLELY TO REPAIR OR REPLACEMENT, AT ONICON'S OPTION, OF DEFECTIVE OR NONCONFORMING PRODUCTS. ONICON SHALL NOT BE LIABLE FOR CONSEQUENTIAL, INDIRECT, PUNITIVE, INCIDENTAL, OR SPECIAL DAMAGES WHETHER FOUND ON CONTRACT, TORT OR ANY OTHER THEORY OF LAW. No products shall be returned to ONICON without its prior consent and transportation and insurance costs shall be prepaid. Any repair or replacement of ONICON's products under the foregoing warranty will be at no charge to the Buyer provided such repair is done at the ONICON factory or authorized service center. ONICON products that are repaired or replaced under this warranty will be returned to Buyer via the same method of shipment use to return the product to ONICON. Repair or replacement of ONICON products is conditioned upon ONICON's acknowledgement of any alleged defect or nonconformance during the warranty period and issuance of a Return Authorization number. All product returns must reference the Return Authorization number on the outside of the shipping carton and on any paperwork referencing the return.
5. **PRICES AND PAYMENT TERMS:** The prices set forth in the most recent quote or acknowledgement as applicable, supersede all previous prices or quotations. All quotations are subject to change or withdrawal without notice except as may be specifically noted on the face of the quotation. The prices shown do not include sales, excise or government charges payable by ONICON to Federal, State, or local authority. Any such tax or charge now or hereafter imposed upon the sale or shipment of the products under this contract will be added to the purchase price. Buyer agrees to reimburse ONICON for such tax or charge or provide ONICON with an acceptable exemption certificate. Payment of invoices will be due 30 days from the date of shipment of the products contained therein. In the event that payment of an invoice is not received by the invoice due date, ONICON will assess a late fee not to exceed 1.5% per month or 18% per year, or the maximum allowable by law whichever is lower.
6. **CANCELLATION:** Buyer may cancel its order, or any part of it, by sending written notice of cancellation to ONICON and paying a reasonable cancellation fee as determined by ONICON. The reasonable cancellation fee will reflect, among other factors, the expenses already incurred and commitments made by ONICON, sales and administrative costs and profit as determined by ONICON. If Buyer received a reduced price based on the quantity of products ordered, but has not purchased the applicable quantity at the time of cancellation, Buyer will pay the price it would have paid had ONICON's sale price been based on the quantity actually purchased.
7. **CHANGES:** If Buyer makes any changes in its drawings, designs, or specifications applicable in any contract with ONICON that cause an increase or decrease in the cost of performance of the contract, or if such changes result in rework or obsolescence, an equitable adjustment shall be made to the contract. Such changes are subject to ONICON's prior written consent.
8. **EXCUSABLE DELAY:** ONICON shall under no circumstance be responsible for failure to fill any order or orders when due to: fires, floods, riots, strikes, freight embargoes or transportation delays, shortage of labor, inability to secure fuel, material supplies, or power at current price or on account of shortages thereof, acts of God or of the public enemy, any existing or future laws or acts of the Federal or State Government (including specifically, but not exclusively, and orders, rules or regulations issued by any official or agency of any such government) affecting the conduct of ONICON's business with which ONICON in its judgment and discretion deems it advisable to comply as a legal or patriotic duty, or due to any cause beyond ONICON's reasonable control.
9. **PATENTS:** ONICON shall defend all suits or proceedings brought against Buyer or its customers arising from claimed infringements of any patent, trademark, service mark or copyright for any product furnished by ONICON and shall indemnify it against all costs, fees, and damages on the condition Buyer promptly notifies ONICON in writing and provides information and assistance to enable ONICON to conduct the defense, provided that ONICON shall have no such obligation in case of infringement resulting from ONICON's conformance to special requirements of Buyer. If ONICON is not able to settle any such suit or proceeding on acceptable terms, ONICON may, at its option, require return of the infringing product and refund the purchase price to Buyer less a reasonable allowance for depreciation or use.
10. **FAIR LABOR STANDARDS ACT:** ONICON represents that all products delivered under this contract are furnished in accordance with the applicable provisions of the Fair Labor Standards Act as amended.
11. **APPLICABLE LAW:** This document and any resulting contract shall be governed by and construed in accordance with the laws of the State of Florida. The courts of the State of Florida and the federal courts located in Florida shall have jurisdiction and venue with respect to litigation to this contract. In the event of litigation, the prevailing party shall be entitled to recover attorney's fees and costs from the non-prevailing party, including appellate attorney's fees.
12. **MODIFICATIONS:** These Conditions of Sale along with the prices, quantities, delivery schedules and other provisions and instructions in applicable quotations by ONICON or Buyer's purchase orders accepted by ONICON shall constitute the entire agreement between ONICON and Buyer pertaining to any resulting contract. They can be modified only in writing.