

Series “W” Water Meters

Model 125-W

Fire Hydrant Meter Aluminum Case, Magnetic Drive Size 3” (DN 80mm)

DESCRIPTION

Model: 125-W Fire Hydrant Meter is based on the turbine principle of measurement; its operating range is from 10 to 350 gallons per minute (2.3 to 70 m³/h) with registration accuracy of 100% ± 1.5% of actual thruput.

Performance: The meter is intended for measuring water from a fire hydrant or other non-permanent installations. The meter comes equipped with standard fire hose swivel couplings and a register lid locking hasp as standard equipment.

Construction: The meter consists of two basic assemblies— the lightweight aluminum maincase and the measuring chamber. Straightening vanes in the maincase minimize the swirl upstream of the meter so as to direct the flow evenly to the rotor. The measuring chamber assembly includes the rotor, a calibration vane which eliminates the need for calibration change gears, and a permanently, hermetically sealed, Direct Reading (DR) register. An orifice plate positioned at the rear of the maincase limits the maximum flow of water through the meter to protect it from over-speeding which could occur when the outflow exits to atmosphere.

Magnetic Drive: The Right Angle Magnetic Drive eliminates conventional worm or miter gears normally required for horizontally mounted rotors or turbine measuring elements. Registration is accomplished by combining the magnetic actions of a driver magnet (embedded in the rear face of the rotor), a three-legged flux carrier and a cylindrical follower magnet attached to the gear train shaft inside the register’s magnet well. Water flowing through the meter causes the rotor (with magnet) to turn; as one of the magnet poles passes one of the flux carrier legs, the magnetic force is transmitted through the flux carrier leg to the follower magnet, causing the register shaft to rotate. The only moving part in water is the rotor assembly.

Rotor: The thermoplastic rotor with a graphite bearing rotates on a chrome plated stainless steel shaft. The rotor assembly is virtually weightless in water, thus adding to bearing life.

Installation: Because the meter is accuracy and pressure tested prior to shipment, no field adjustments are required. For proper accuracy, the meter must have an input of a full flow of liquid.

Maintenance: If necessary, the measuring chamber can be removed from the maincase for maintenance without having to remove the maincase from the installation. Either a spare measuring chamber or a cover plate can be used if water service must be maintained.

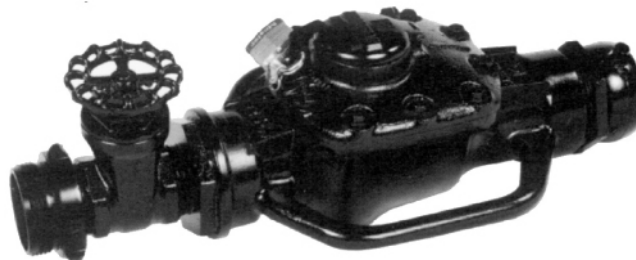

Model 125-W Fire Hydrant Meter
(Shown with optional outlet gate valve and register locked for security)

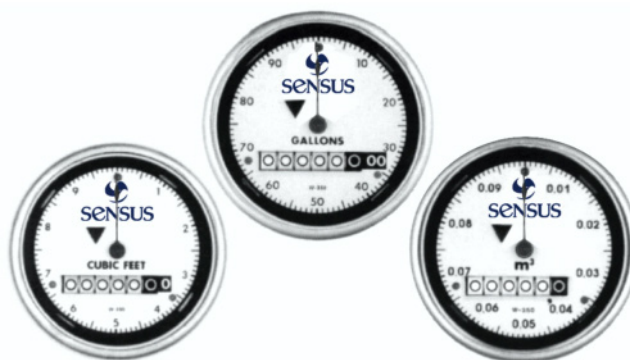

Direct Reading Registers

Head Loss Curve

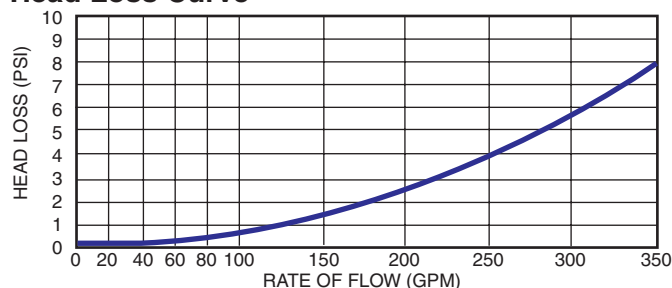

Accuracy Curve

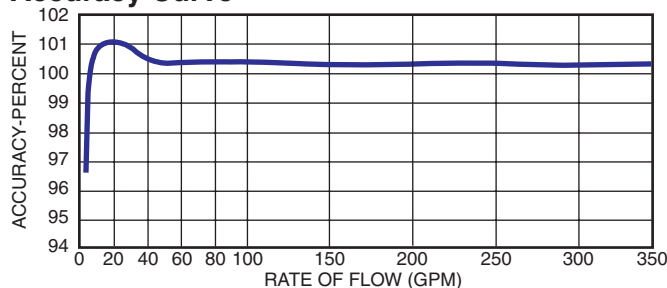

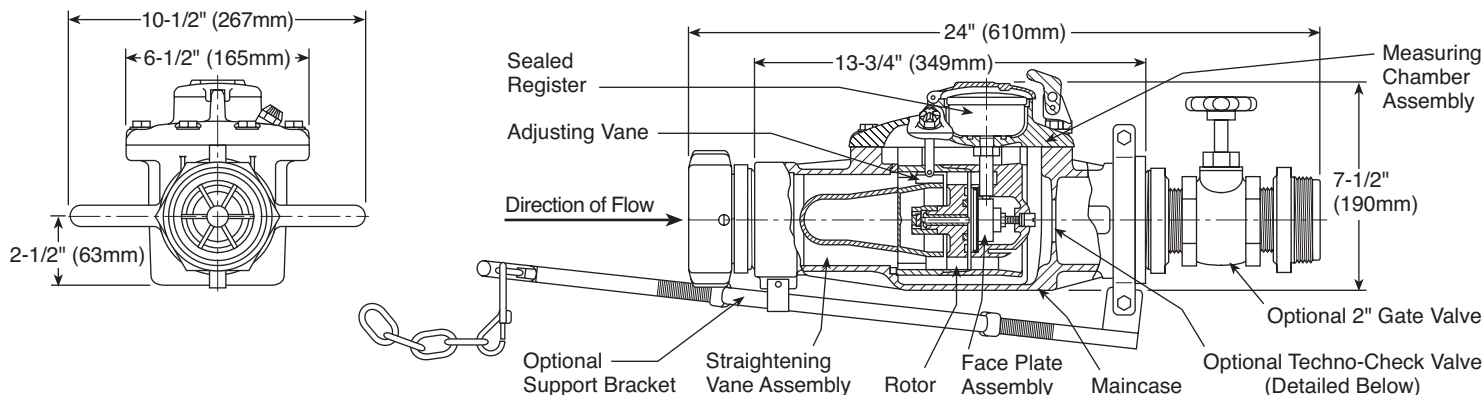

2-1/2" - 7-1/2 NSTThreads or 2-1/2" - 5 CSAThreads Standards (Other optional special threads available upon request.)

SPECIFICATIONS FOR SPECIAL FIRE HOSE COUPLING THREADS

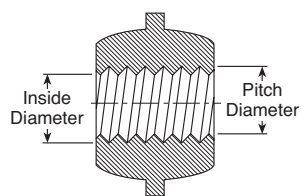

Female Threads

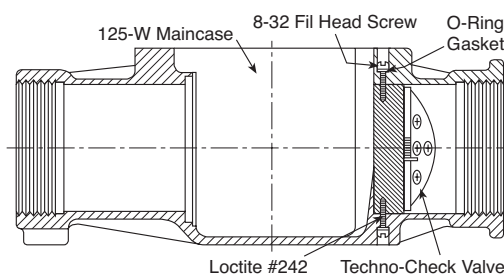

Techno-Check Valve

The Techno-Check Valve is a reverse flow protection device for the model 125-W fire hydrant meter. It is a factory installed add-on only. Shown installed in the meter's outlet port (A) and removed (B).

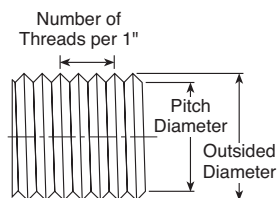

Male Threads

Required Information

1. Number of threads per inch and thread form, if other than American National Standard or Canadian Standards Association.
2. Outside diameter of male threads.
3. Pitch diameter of male threads.
4. Inside diameter of female threads.
5. Pitch diameter of female threads.

Weight

- Meter Only Net18 lbs. (10 kg)
- Meter Only Shipping. 22 lbs. (12 kg)
- Meter & Fittings Net 26 lbs. (13.6 kg)
- Meter & Fittings Shipping 30 lbs. (15.4 kg)

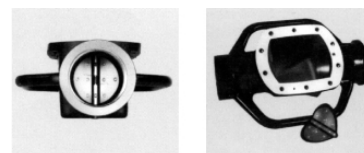

A B

SPECIFICATIONS

SERVICE	Measurement of cold water up to 80°F (27°C) with flow in one direction only
OPERATING FLOW RANGE ¹	Continuous Flows: 10-350 gpm (2.3 to 70 m ³ /h) Intermittent Flows: 400 gpm max. (90 m ³ /h)
ACCURACY	100% ± 1.5% of actual thruput
LOW FLOW	95% at 6 gpm (1.4 m ³ /h)
PRESSURE LOSS	8 psi at 350 gpm (0.6 bar at 80 m ³ /h)
MAXIMUM OPERATING PRESSURE	150 psi (10.0 bar)
HOSE COUPLINGS	2-1/2"-7-1/2 NST threads (78P - 3.4mm) (National Standard Fire Hose Coupling Thread) furnished unless otherwise specified. Complete thread specifications must be furnished for special fire hose fittings.
REGISTER	Hermetically Sealed Direct Reading Register with Low Flow Indicator
METER REGISTRATION	100,000,000 gallons 100 gallons/sweep hand revolution 10,000,000 cubic feet 10 cubic feet/sweep hand revolution 100,000 m ³ 0.1 m ³ /sweep hand revolution

MATERIALS	Maincase—Cast Aluminum Alloy Measuring Chamber—Thermoplastic Straightening Vanes—Thermoplastic Rotor—Thermoplastic Radial Bearing—Graphite Thrust Bearings—Tungsten Carbide Magnets—Ceramic Flow Tube—Thermoplastic
OPTIONS	Available with: Stainless steel internal strainer on inlet hose connection Gate valve on outlet end Techno-Check reverse flow protection device Adjustable support rod assembly Blank cover for maincase Available without: Fire hose fittings assembled
FLOW RESTRICTION	Limits flow thru meter to 400 gpm at 60 psi (90 m ³ /h at 4 bar)

AUTHORIZED SENSUS DISTRIBUTOR



P.O. Box 487 | 450 North Gallatin Avenue
Uniontown, PA 15401 USA
T: 1-800-638-3748
F: 1-800-888-2403
www.sensus.com/water
h2oinfo@sensus.com

| sales@mvandc.com | Phone: 877.566.3837 | Fax: 925.407.2903