

SAGE THERMAL GAS MASS FLOW METER

User Manual

For Prime Models SIP and SRP

DOCUMENT NUMBER 100-0065
REV. 29-SIP/SRP (SAGE PRIME™)

Make the Wise Choice.
Choose Sage Flow Meters.



SAGE METERING, INC.
8 Harris Court, Bldg. D
Monterey, CA 93940
1-866-677-SAGE (7243)
Tel 831-242-2030
Fax 831-655-4965
www.sagemetering.com



Table of Contents

Introduction	Welcome	5
SECTION A Getting Started	Unpacking Your Sage Meter	9
	Maintenance	9
	Calibration	9
	Installation and Mounting	10
	Locating Proper Wiring Diagram	10
	Insertion Flow Meter Application	11
	Sage Valve Assembly Operation	11
	Compression Fitting Operation	12
	Installation Instructions	12
	Captive Flow Conditioners	13
	Probe Insertion Guideline Drawing	14
	1/2" Prope Diameter Installation Chart	15
	3/4" Prope Diameter Installation Chart	16
	Recommended Probe Lengths Data Sheet	17
	Large Duct or Stack Applications	18
	In-line Flow Meter Application	19
	Electrical Wiring	20
	24 VDC Powered Meters	21-24
	110 VAC Powered Meters	25-26
	24 VDC Powered Meter, HART Enabled	27
110 VAC Powered Meter, HART Enabled	28	
Remote Cable Wiring	29	
SECTION B Styles and Features	Principle of Operation	33
	Features and Benefits	34
	Sage PRIME Styles & Specifications	35
	Sage PRIME Organic (OLED) Display	36
	Approvals	37
SECTION C Drawings	SIP Series Integral Style Flow Meters	41
	SRP Series Remote Style Flow Meters	42
	Remote Bracket Layout	43
	Mounting Hardware:	
	1/2" SVA05 Series Isolation Valve Assembly for Insertion Meters	44
	STCF Series Teflon Ferrule Compression Fitting	44
	SVA05 Series Isolation Valve Assembly Detail	44
Mounting Plate for Thin Walled Ducts	44	

continued on next page

SECTION C	3/4" SVA07 Series Isolation Valve Assembly for Insertion Meters	45
Drawings	STCF Series Teflon Ferrule Compression Fitting	45
	SVA07 Series Isolation Valve Assembly Detail.	45
	SVA05LP Low Pressure Isolation Valve Assembly.	46
	In-Line and Insertion Flanges	47
SECTION D	Common Diagnostics	51
Diagnostics	In-Situ Calibration Check	54
SECTION E	Limited Warranty	57
Warranties and Service Work	Cancellation/Return Policy	57
	Returning Your Sage Flow Meter	59
	Return Material Authorization Form	60
SECTION F	Modbus Register Listing	63
Modbus	Modbus Protocol & Function Codes	64
	Sage Register Output Format.	69
	Sage Addresser Software	69
	Sage Addresser Typical Printout (Version 3.14)	70
SECTION G	HART Menu Tree.	73
HART (Optional)	HART	75
SECTION H	Sage Prime Service Department "Dongle"	81
Appendix	Correction Factors For Varying Gas Mixes	82
	Installations Where Pipe Condensation May Develop	82
	J-Box and Upstream Orientation	83
	What Is a Thermal Mass Flow Meter?.	84

Welcome

We are pleased that you have purchased a Sage Metering Mass Flow Meter for your requirement. We hope that you are satisfied with the performance, operation and design of our highly precise, NIST traceable Thermal Gas Mass Flow Meter.

Sage Metering is your source for monitoring, measuring and controlling the gas mass flow in your industrial process, building management system or environmental application. Our high performance, NIST Traceable, Thermal Mass Flow Meters will help increase productivity, reduce energy costs, maximize product yields, and/ or help reduce environmental insult. Sage provides high quality In-Line and Insertion Thermal Mass Flow Meters for a wide variety of industrial, commercial, and environmental monitoring needs, including carbon credit verification for Greenhouse Gas reduction.

Sage Meters measure mass flow directly — there is no need for ancillary instrumentation such as temperature or pressure transmitters. Furthermore, our instruments have exceptional signal sensitivity, have no moving parts, require little if any maintenance, have negligible pressure drop and have a turn-down up to 100 to 1, and resolve as much as 1000 to 1. Sage Flow Meters can measure the mass flow rate and consumption of air, oxygen, natural gas, nitrogen, digester gas, biogas, flare gas, hydrogen, argon, carbon dioxide and other gases and gas mixes.

Sage Prime is the latest addition to our family of high performance Thermal Mass Flow Meters. It features a bright graphical display of Flow Rate, Total and Temperature, robust industrial enclosure, and easy to access power and output terminals. Sage Prime has a dual-compartment windowed enclosure featuring a very high contrast photo-emissive OLED display with a new photocell activated Screen Saver. The rear compartment, which is separated from the electronics, has large, easy to access and well marked terminals, for ease of customer wiring. It is powered by 24 VDC (12 VDC optional, or 115/230 VAC). The power dissipation is under 2.5 watts (e.g. under 100 mA at 24 VDC for the DC version.)

Please let us know if we can assist you in any way with your Sage Meter, or if you have any questions about its installation, operation, or features. Simply phone us at 866-677-SAGE (7243), or visit our website at www.sagemetering.com to contact a factory representative in your area. This manual is available on the website under Knowledge Base section.

Sincerely,

Robert Steinberg
President



Section **A**

GETTING STARTED

Getting Started

UNPACKING YOUR SAGE METER

Your Sage flow meter is a sensitive, yet rugged, precision built electronic instrument. Upon delivery, care should be taken when opening the shipping container and removing your meter. The meter should be inspected for any damage that may have occurred during transit. If damage is found, please contact the carrier immediately to place a claim for damaged goods. The contents of the container should be checked against the packing list for any discrepancies. If there are any questions as to the contents or configuration of the equipment including calibration ranges, or, mounting hardware, contact Sage Metering as soon as possible. Please save shipping container and packaging materials (including PVC tube probe protector on Sage Insertion Flow Meters) in case the unit needs to be returned for any reason.

MAINTENANCE

Sage thermal mass flow meters essentially require little or no maintenance. While the sensing element is somewhat resistant to dirt and particulate build up, it may become necessary to clean it from time to time if mounted in extremely dirty environments. **NOTE: ALWAYS REMOVE THE POWER PRIOR TO ANY CLEANING OR MAINTENANCE.** A detergent or

appropriate non-corrosive solvent for removing the buildup may be required. A soft brush can be used to gently clean the sensing element's surface, using caution to avoid damaging the sensor elements (the RTDs). If any disassembly is necessary, contact Sage Metering, Inc. for instructions. **In general, it is recommended that your Sage Thermal Mass Flow Meter be returned to the factory if cleaning, repair, or recalibration is needed. This is usually the most cost-effective and reliable alternative.**

CALIBRATION

Sage Prime has continuous diagnostics. The raw calibration milliwatts (mW) is always displayed in the upper left hand corner of the meter's display. At any time, you can check this reading at a "no flow" condition and compare the reading to the original reported "zero flow" value noted on the last few lines of your meter's Certificate of Conformance or the flow meter's data tag. This diagnostic procedure not only checks the sensor performance and the "live zero" calibration point, but it verifies that the sensor is clean. It essentially provides a means to validate the meter's performance, verifies that there is no shift or drift, and may eliminate the need for annual factory calibrations. This simple field diagnostic procedure also verifies that the sensor is free from contamination, even without inspection. See "In-Situ Calibration Check" on page 53.



CAUTION Cable glands shipped with unit are for shipping purposes only. Remove shipping cable glands before installing.



CAUTION If installing in a Class I hazardous location the installation must comply with appropriate electrical codes.



CAUTION Installer must supply proper ground and bond wire for the transmitter and the sensor per appropriate electrical codes

REFER TO EN60079-14 STANDARD FOR ELECTRICAL INSTALLATIONS

Check the Certificate of Conformance included with your Sage Thermal Mass Flow Meter for system pressure, temperature, gas composition, power input, and signal output.

It is recommended that the flow meter be inserted in a location of maximum straight run. See chart on page 11. Note, obstructions such as valves, blowers, expanders and PVC and HDPE pipes will require additional straight run (contact factory for assistance).

Check the orientation¹: Standard calibration flow direction is left to right when facing the flow meter. Gas flow direction is marked with an arrow on in-line flow meters; UPSTREAM is marked on insertion probes.

Do not rotate probe¹, or errors may occur. If enclosure is facing incorrectly, rotate the enclosure 180°, but do not rotate the probe. The UPSTREAM mark still needs to be facing Upstream.

Hook up the system per the wiring diagram provided with your Sage flow meter (see inside of rear compartment cover for terminal designation). Double check that wiring for the proper power and signal connections are correct.

Check that all plumbing and electrical hook-ups are in accordance with OSHA, NFPA, and all other safety requirements.

For Remote Style Meters (SRP) be sure the Remote Electronics is matched with the Transmitter's Junction Box and its attached Probe or Flow Body. There will be Metal Serial Number Tags on both the Transmitter as well as the Remote Electronics enclosure. Do not mismatch the serial numbers of the Remote Electronics and the Junction Box, or calibration errors will occur.

LOCATING PROPER WIRING DIAGRAM

See pages 20-29 for electrical wiring of the Sage Prime. There is an illustration in the electronics cover which shows wiring connections.

See page 20 for a wiring diagram of the DC or AC input power. Page 20 and 28 give wiring connections for the output signals. For units with remote electronics, the wiring in the electronics enclosure is made at Sage Metering; page 29 gives wiring illustration for wiring the cable at the remote terminal enclosure.

Note: Do not open the display side of the enclosure.

¹ The Integral Style of Sage Prime Insertion Meters have the Display oriented as shown on page 14. If an alternate orientation of the display, or enclosure is required (ie. installation into a vertical pipe), please furnish a sketch or drawing, and specify "ROTATE" on purchase order. However, if it is later determined that the enclosure needs to be rotated, that procedure can be done in the field. However, if the display needs to be rotated, then the meter must be sent back to Sage to be modified. Do not attempt this in the field. An RMA will be required prior to returning the meter (see page 59). The procedure for rotating the enclosure is as follows: Clamp the enclosure of the Prime in a vise with the probe pointing up to the ceiling. Then take a 7/8 wrench and turn the probe to the proper orientation. Lock the probe into its new position with a set screw (not provided).

Insertion Flow Meter Application

FLOW PROFILE AND INSTALLATION CONSIDERATIONS

Insertion Flow Meters, although generally easier to install than In-Line Flow Meters, require proper installation, and a well developed flow profile, in order to perform properly. Please refer to the section on the following pages titled PROBE INSERTION GUIDELINE DRAWING (page 14) 1/2" INSTALLATION DEPTH CHART (page 15) and 3/4" PROBE INSTALLATION DEPTH CHART (page 16).

SAGE VALVE ASSEMBLY OPERATION

Valve assemblies (SVA05LP, SVA05, SVA07) are an optional mounting hardware for Insertion Style Flow Meters (see pages 44 - 46). They allow the removal of insertion-style meters for service, cleaning, recalibration, relocation, etc. without the need to "shut-down" your process. The probe insertion depth is adjustable to permit sensor to be located at center to optimize measurement accuracy. (Refer to PROBE INSERTION GUIDELINE DRAWING and CHART, pages 14, 15 & 16.) The ball valve will seal off leaks of the process gas at the point of insertion after the probe assembly has been removed. The assembly includes a valve, threadolet, compression fitting with Teflon ferrule, as well as a cable restraint, and two collar clamps (except for SVA05LP).

A threaded half coupling as defined below, must be fit-



SVA05LP
3/4" FNPT
THREADED HALF
COUPLING



SVA05
3/4" FNPT
THREADED HALF
COUPLING



SVA07
1" FNPT
THREADED HALF
COUPLING

ted to the pipe/duct to which the insertion probe will be inserted. Avoid T-Fittings since they will disturb the flow profile, and effectively reduce the measurement area. Direct threading together (or with necessary bushings) of the retractor assembly may be required. In other cases, the threadolet must be welded in place and a clearance hole must be drilled through the pipe/ duct to accept the probe assembly. If the pipe/duct is under pressure during installation, a hot tap drill (not available through Sage Metering) may be required.

FLOW CONDITIONING AND STRAIGHT RUN

To absolutely assure that the flow profile is well developed at the point of measurement, either use Flow Conditioners (standard in Sage In-Line Flow Meters, 1/2" and larger, and also available as assemblies for Insertion Flow Meters, see page 13), or consider additional straight run. The Chart below provides examples of the amount of straight run that would virtually assure that there are no flow disturbances at the point of measurement.

IMPORTANCE OF FLOW CONDITIONING Recommended Pipe Diameters Upstream			
DISTURBANCE	WITHOUT FLOW CONDITIONING		WITH FLOW CONDITIONING ¹
	Sage Recommendation		Sage Recommendation
One 90° Elbow	25		3
Two 90° Elbows in the same plane	36		5
Two 90° Elbows in different planes	62		9
4:1 Area Reduction	18		3
4:1 Area Expansion	84		10
Multiple Disturbance	TBD		TBD

¹ This column applies to In-Line Flow Meters, which come standard with built-in Flow Conditioners, as well as Insertion Meters, when provided with upstream Captive Flow Conditioners (see page 13).

COMPRESSION FITTING OPERATION

A bored through tube fitting, properly sized to accommodate an insertion probe's particular OD, can be provided by the user or purchased as an option from Sage Metering (see page 44). Prior to installation, a clearance hole to accommodate the insertion probe assembly must be drilled in the pipe/duct. A fitting (1/2" FNPT) is then welded in place or threaded into the half-threadolet which has been welded to the pipe/duct. The probe insertion depth is adjustable to permit sensor to be located at center, to optimize measurement accuracy. (Refer to PROBE INSERTION GUIDELINE DRAWING and CHART, pages 14 & 15.)

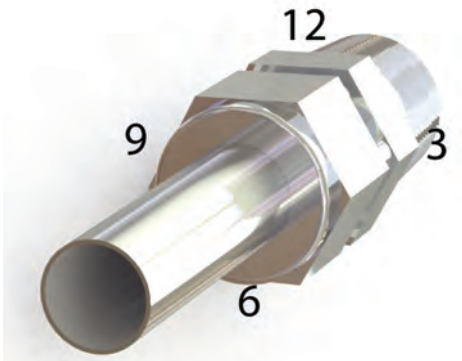

Insert the probe shaft tubing into the compression fitting to the position indicated in the Probe Insertion guidelines.

INSTALLATION INSTRUCTIONS

1. Insert tubing into the tube fitting.
2. Make sure that the tubing is positioned properly per the PROBE INSERTION GUIDELINE DRAWING AND CHART, pages 14 & 15.
3. Due to the variations of tubing diameters, a common starting point is desirable. Therefore, tighten the nut until the tubing will not turn by hand or move axially in the fitting.
4. Scribe the nut at the 6 o'clock position.
5. While holding fitting body steady, tighten the nut 1/4 turns to the 9 o'clock position.

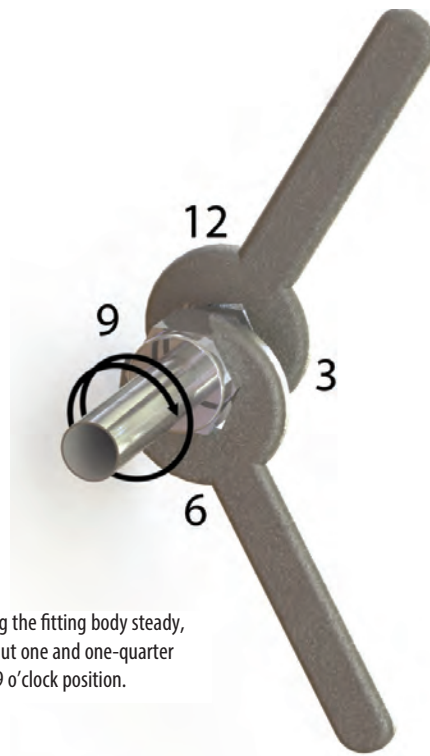

While holding the fitting body steady, tighten the nut one and one-quarter turns to the 9 o'clock position.

**CAPTIVE FLOW CONDITIONERS
Can Be Installed in Conjunction with Insertion Style Flow Meters**

IMPORTANT The location of the probe must be one pipe ID diameter (i.e., 4" in a 4" pipe; 6" in a 6" pipe, etc.) downstream of the Captive Flow Conditioning assembly. The Captive Flow Conditioners are always designed to be separated by one pipe diameter. See drawing below. The probe location must be one pipe ID diameter downstream of Flow Conditioner, or errors will occur.

IMPORTANT If employing Captive Flow Conditioners, it is essential that the accompanying Sage Flow Meter be calibrated for use with a Flow Conditioner. Thus, do not order a Flow Conditioner separate from the Flow Meter, unless the Flow Meter part number is "- FC".

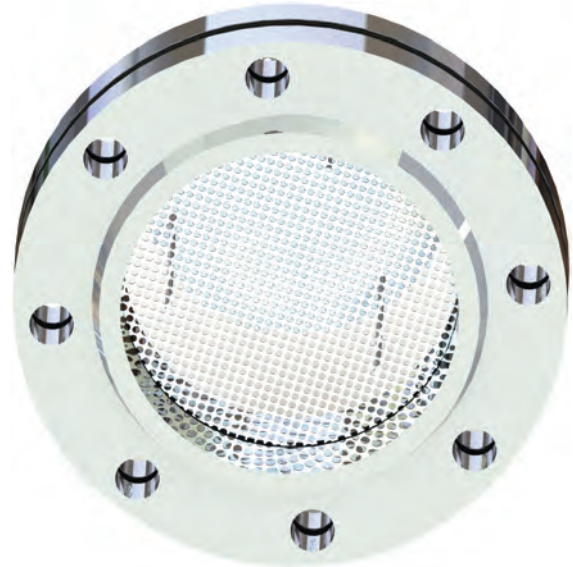
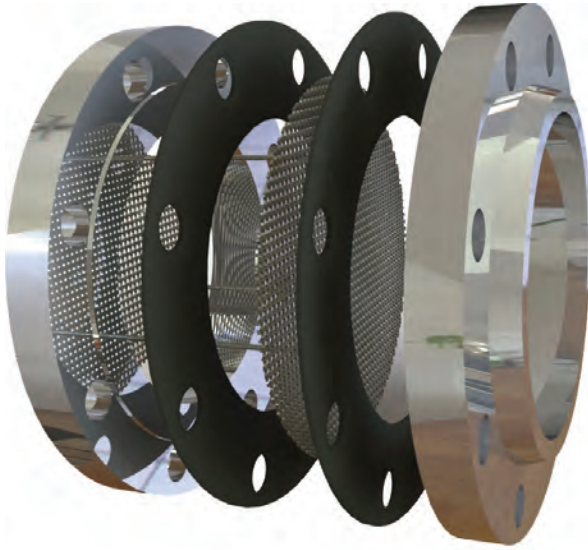

Front View of one of the Conditioning Plates

Note: See table on page 11 (last Column) for Straight Run Requirement

Greatest Dia. of the two perforated plates



Gaskets

ANSI Class Flanges (user supplied)

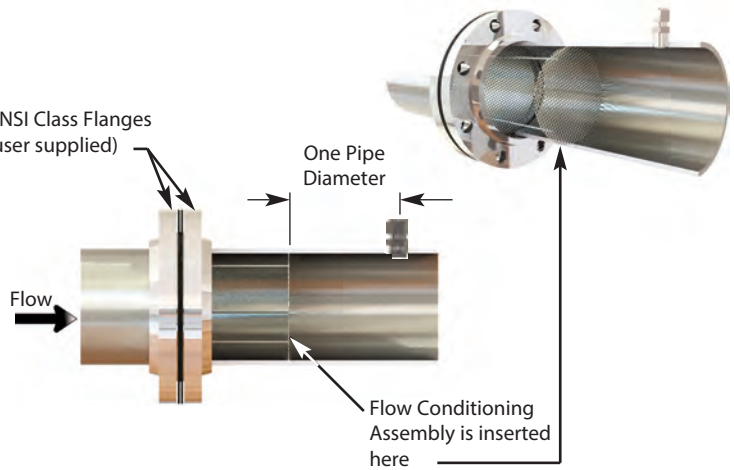

NOTE: The larger of the two perforated plates of the Sage Flow Conditioning assembly is positioned between two flanges and two gaskets as shown. The smaller of the two perforated plates of the conditioner will freely slide into the application pipe, facing downstream. The probe mounting hardware will be placed one diameter downstream of the downstream plate. Probe location must be one pipe ID diameter downstream of Flow Conditioners or errors will occur.

PROBE INSERTION GUIDELINE DRAWING¹

Choose the longest straight-run section of pipe available to allow a uniform, well-developed flow profile. See chart on page 15 for specifications. Note, obstructions such as valves, blowers expanders and PVC and HDPE pipes will require additional straight run (contact factory for assistance). Avoid, if possible, installations immediately downstream of bends, fans, nozzles, heaters and especially valves, or anything else installed in the line that may cause nonuniform flow profiles and swirls. Otherwise signal output errors could result, unless significantly more straight run is provided, or in the absence of sufficient straight run, Flow Conditioners (page 13) are installed (contact Sage for assistance if needed). Refer to page 13 to see the benefits of incorporating Flow Conditioners.

Insertion styles are available through Sage Metering, Inc. with a standard 1/2" OD probe support assembly; 3/4" is also available. Standard probe lengths are 6", 12", 15", 18", 24", 30", 36" and 48". A common method of mounting the probe assembly through a pipe wall or duct (if ambient air) is with a compression fitting (STCF05). A Sage valve assembly (SVA05) is useful and highly recommended for pressurized applications or other gases, such as Natural Gas. Flange mounting is optionally available.

Sage insertion style flow meters can be assembled and calibrated for use in virtually any size pipe or duct (as small as 1"). Sage insertion flow meters include a probe assembly that supports the sensing element (a self-heated flow sensor and a temperature/reference sensor); a sensor drive circuit; microprocessor meter board, and transmitter enclosure.

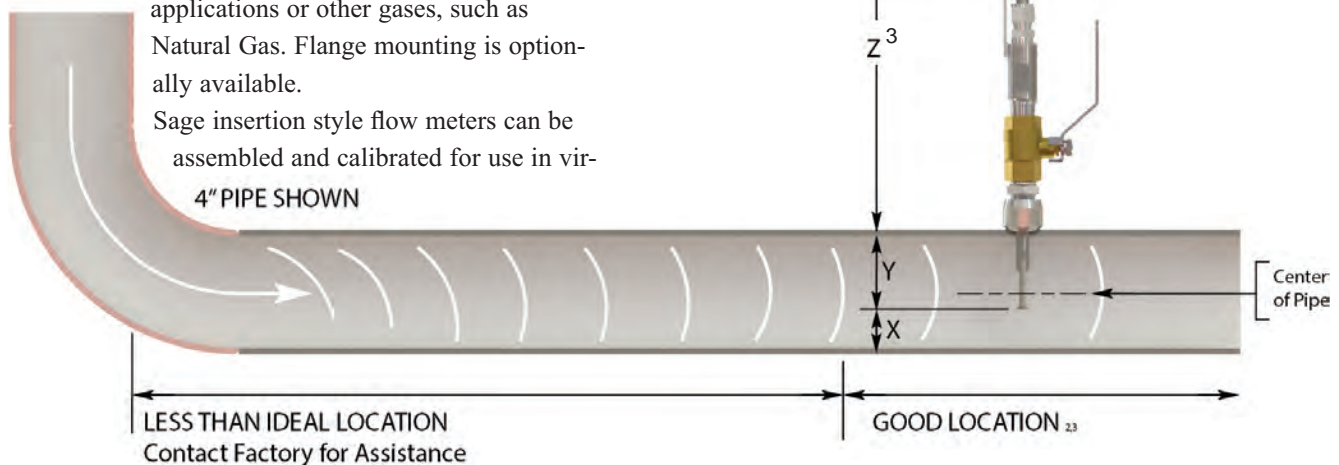

usually any size pipe or duct (as small as 1"). Sage insertion flow meters include a probe assembly that supports the sensing element (a self-heated flow sensor and a temperature/reference sensor); a sensor drive circuit; microprocessor meter board, and transmitter enclosure. The probe assembly must be inserted into the correct position in the process gas flow conduit to allow the gas to flow through the sensor "window" across the sensor element. The "sensing point" or active part of the sensor (0.5" from the end of the probe) should be positioned as per the drawing below and the Installation Depth Chart on page 15.

Installation Depth²

The center of the pipe (assuming a well developed turbulent flow profile) is fairly flat, and easy to locate. See "Installation Depth Chart" on next page to determine proper insertion depth.

1. SIP Industrial Meter shown in drawing. Note, probe is not bi-directional.
2. Probe should be inserted per Installation Depth Chart (see following page) so sensors are in the center of the pipe.
3. The portion of the probe that remains outside of the pipe, is simply the factory ordered probe length (i.e. "-15" = 15 inches) minus the "Y" dimension.

1/2" PROBE DIAMETER INSTALLATION CHART

Methods for Probe Insertion to Pipe Center

METHOD 1

Using charts below, select pipe size (column 1), determine X. Insert probe until the end touches the bottom of the pipe (ID), mark probe as it exits top of fitting. Lift probe distance "X" and tighten compression fitting.

METHOD 2

Using charts below¹, select pipe size (column 1), determine Y. Subtract Y from the factory supplied probe length. That difference Z (see drawing on page 14) should be outside of the pipe, and is measured from the bottom of the enclosure of the probe weld to pipe OD.

¹ The 1" Pipe size needs to have Probe "bottomed Out" (option "BOT"); the calibration method for the 1 1/2" Pipe is either as shown below, or with option "BOT"

² For other Pipe schedules, such as Schedule 10, contact Sage, however the Y dimension will be the same for any Schedule Pipe.

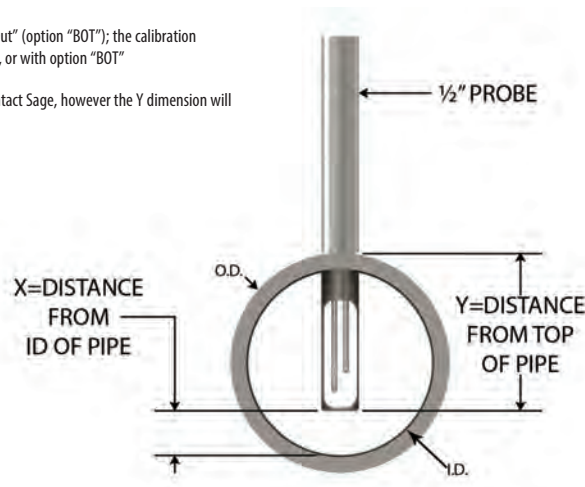

SCHEDULE 40 PIPE ²					
PIPE SIZE	OD	ID	X	Y	PIPE AREA
1" ¹	C O N S U L T F A C T O R Y				
1.5"	1.900	1.610	.20"	1.56"	0.0141
2"	2.375	2.067	.40"	1.82"	0.0233
2.5"	2.875	2.469	.60"	2.07"	0.0332
3"	3.500	3.068	.90"	2.38"	0.0513
4"	4.500	4.026	1.40"	2.86"	0.0884
6"	6.625	6.065	2.40"	3.95"	0.2006
8"	8.625	7.981	3.40"	4.90"	0.3474
10"	10.750	10.020	4.40"	6.00"	0.5476
12"	12.750	11.938	5.50"	7.00"	0.7773
14"	14.000	13.124	6.00"	7.50"	0.9394
16"	16.000	15.000	7.00"	8.60"	1.2272
18"	18.000	16.876	8.00"	9.60"	1.5533
24"	24.000	22.625	10.75"	12.60"	2.7919

SCHEDULE 80 PIPE ²					
PIPE SIZE	OD	ID	X	Y	PIPE AREA
1" ¹	C O N S U L T F A C T O R Y				
1.5"	1.900	1.500	.15"	1.56"	0.0123
2"	2.375	1.939	.35"	1.82"	0.0205
2.5"	2.875	2.323	.55"	2.07"	0.0294
3"	3.500	2.900	.80"	2.38"	0.0459
4"	4.500	3.826	1.30"	2.86"	0.0798
6"	6.625	5.761	2.25"	3.95"	0.1810
8"	8.625	7.625	3.25"	4.90"	0.3171
10"	10.750	9.750	4.25"	6.00"	0.5185
12"	12.750	11.374	5.13"	7.00"	0.7056
14"	14.000	12.500	5.70"	7.50"	0.8522
16"	16.000	14.312	6.60"	8.60"	1.1172
18"	18.000	16.124	7.50"	9.60"	1.4180
24"	24.000	21.562	10.25"	12.60"	2.5357

3/4" PROBE DIAMETER INSTALLATION CHART

Methods for Probe Insertion to Pipe Center

METHOD 1

Using charts below, select pipe size (column 1), determine X. Carefully insert probe until the end touches the bottom of the pipe (ID), mark probe as it exits top of fitting. Lift probe distance "X" and tighten compression fitting.

METHOD 2

Using charts below¹, select pipe size (column 1), determine Y. Subtract Y from the factory supplied probe length. That difference Z (see drawing on page 14) should be outside of the pipe, and is measured from the bottom of the enclosure of the probe weld to pipe OD.

¹ For other Pipe Schedules, such as Schedule 10, contact Sage, however the Y dimension will be the same for any Schedule Pipe

² The 1" Pipe Size needs to have the Probe "Bottomed Out" (option "BOT"); the calibration method for the 1½" Pipe is either as shown below, or with option "BOT"

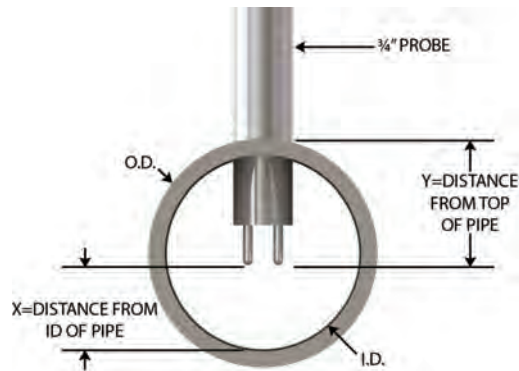

SCHEDULE 40 PIPE ²					
PIPE SIZE	OD	ID	X	Y	PIPE AREA
1" ¹	C O N S U L T F A C T O R Y				
1.5"	1.900	1.610	.63"	1.10"	0.0141
2"	2.375	2.067	.86"	1.34"	0.0233
2.5"	2.875	2.469	1.07"	1.59"	0.0332
3"	3.500	3.068	1.37"	1.90"	0.0513
4"	4.500	4.026	1.85"	2.40"	0.0884
6"	6.625	6.065	2.87"	3.47"	0.2006
8"	8.625	7.981	3.83"	4.47"	0.3474
10"	10.750	10.020	4.85"	5.53"	0.5476
12"	12.750	11.938	5.81"	6.53"	0.7773
14"	14.000	13.124	6.41"	7.15"	0.9394
16"	16.000	15.000	7.35"	8.15"	1.2272
18"	18.000	16.876	8.28"	9.15"	1.5533
24"	24.000	22.625	11.16"	12.15"	2.7919

SCHEDULE 80 PIPE ²					
PIPE SIZE	OD	ID	X	Y	PIPE AREA
1" ¹	C O N S U L T F A C T O R Y				
1.5"	1.900	1.500	.57"	1.10"	0.0123
2"	2.375	1.939	.80"	1.34"	0.0205
2.5"	2.875	2.323	.99"	1.59"	0.0294
3"	3.500	2.900	1.28"	1.90"	0.0459
4"	4.500	3.826	1.75"	2.40"	0.0798
6"	6.625	5.761	2.72"	3.47"	0.1810
8"	8.625	7.625	3.66"	4.47"	0.3171
10"	10.750	9.750	4.72"	5.53"	0.5185
12"	12.750	11.374	5.53"	6.53"	0.7056
14"	14.000	12.500	6.09"	7.15"	0.8522
16"	16.000	14.312	7.00"	8.15"	1.1172
18"	18.000	16.124	7.91"	9.15"	1.4180
24"	24.000	21.562	10.63"	12.15"	2.5357

RECOMMENDED PROBE LENGTHS DATA SHEET:

SAGE - Revised May 2018	1/2" PROBE (- 05)	1/2" PROBE (- 05)	1/2" PROBE (- 05)	3/4" PROBE (- 07X)
	STCF05 height 2.5	SVA05LP height 7.5	SVA05 height 11.0	SVA07 height 13.0
Pipe size	Recommended probe length	Recommended probe length	Recommended probe length	Recommended probe length
1	6	12	15	15
1 1/2	6	12	15	18
2	6	12	15	18
2 1/2	6	12	15	18
3	6	12	15	18
3 1/2	6	15	15	18
4	6	15	15	18
6	12	15	18	18
8	12	15	18	24
10	12	18	18	24
12	12	18	24	24
14	12	18	24	24
16	12	20	24	24
18	15	20	24	24
20	15	22	24	30
24	18	24	30	30
36	24	30	36	36

In-Line Flow Meter Application

IN-LINE FLOW METERS

In-line mounting styles are available through Sage Metering, Inc. in sizes from 1/4" pipe through 4" pipe. Threaded male NPT ends are standard up to 2-1/2"; ANSI 150lb flanged ends are recommended for 3" and 4" models. Contact the factory if optional end mounting styles are required. Pipe sizes in excess of 4" require the insertion style mass flow meter.

The in-line style flow meter assembly flow section is typically specified to match the user's flow conduit and is plumbed directly in the flow line by threading,

flanging, welding, etc. **DO NOT USE REDUCERS.** It includes the sensing element (a self-heated flow sensor and a temperature/reference sensor) mounted directly in the specified flow section for exposure to the process gas; a sensor drive circuit; microprocessor meter board, and transmitter enclosure.

All in-line Flow Meters, 1/2" and up have built-in Flow Conditioners. See Table (page 11) for Upstream Straight run requirements. Note, the 1/4" and 3/8" do not have Flow Conditioners and thus require more straight run.

FLOW CONDITIONING SCREENS FOR IN-LINE FLOW BODIES 1/2" AND UP¹

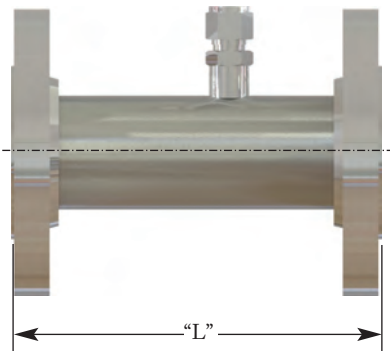

LENGTH "L" SAME AS NON-FLANGED METER
 (See table on page 40. For example, 1"x8" flow body has an 8" length. The length will be the same whether an NPT flow body, or whether flanged. If a flanged flow body, the 8" dimension will be a Face-to-Face dimension.)

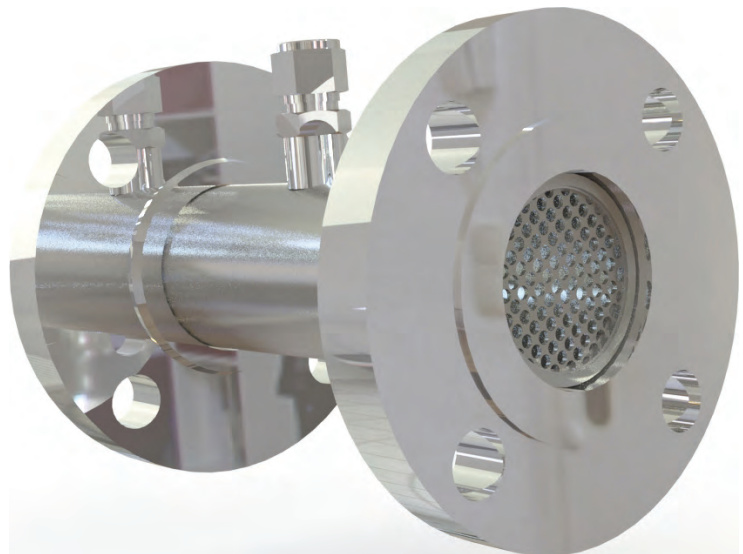

Screens shown with NPT fitting.

¹ Note, Flow conditioning is also available for Insertion Meter applications (see page 13)

Electrical Wiring

All wiring connections are made in the terminal block compartment of the enclosure.

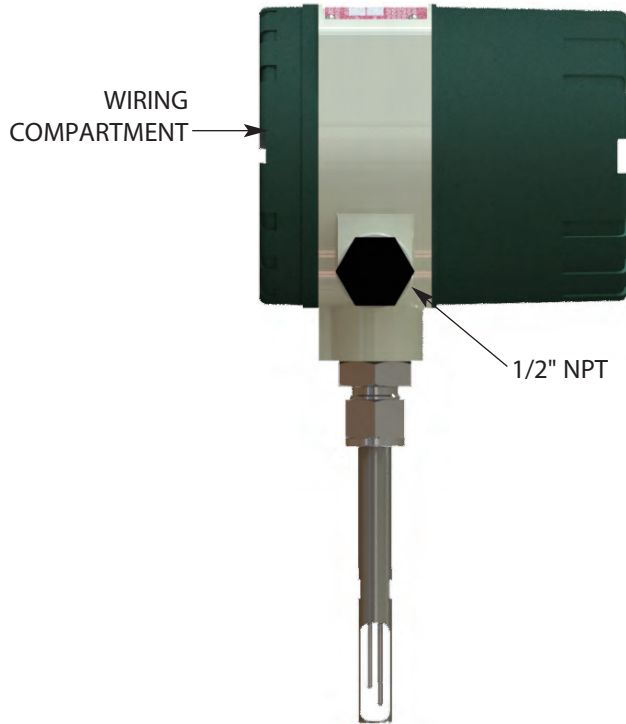

INSIDE COVER VIEW

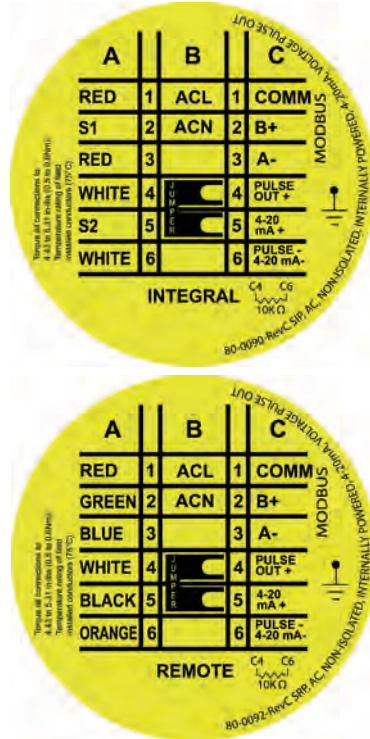

INPUT POWER

The Sage Prime requires supplemental power in the form of 24 VDC or 115/230 VAC. Power requirements at 24 VDC is 2.4 watts. The AC and DC ground con-

nections are made at the green grounding screw located adjacent to the terminals. Hazardous Area approval is only available on 24 VDC units.

AC POWER		
	115	230
AC1	Line	Phase A
AC2	Neutral	Phase B

SAGE PRIME 4-20mA & VDC PULSE OUT 24 VDC

Standard PRIMES are shipped with a jumper between pins B4 & B5. This jumper provides +24 VDC to pin B4 to power the 4-20 mA and Pulse outputs. (Note: If isolated 4-20mA and / or pulse output is required, the jumper must be removed. A separate power supply must be used to supply power to pin B4 for these isolated outputs.)

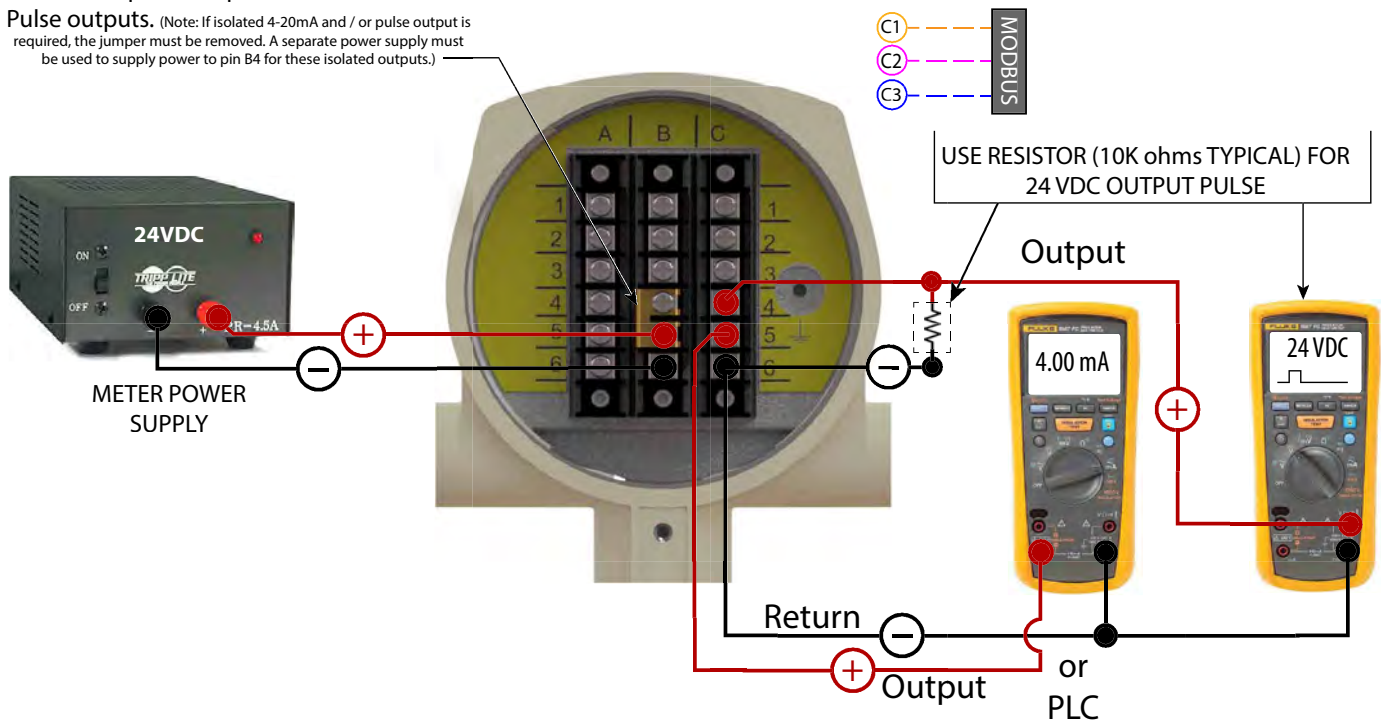

80-0091-RevB SIP, DC, NON-ISOLATED, INTERNALLY POWERED, 4-20mA VOLTAGE PULSE OUT

	A	B	C	
RED	1		1	COMM
S1	2		2	B+
RED	3		3	A-
WHITE	4		4	PULSE OUT +
S2	5		5	4-20 mA +
WHITE	6	VDC GND	6	PULSE - 4-20 mA-

MODBUS C4 C6
10KΩ

Integral

torque all connections to 4-05 to 5-31 In-lbs (0.5 to 0.6Nm). Insulate all connections with heat-shrink tubing. Insulated conductors (75°C).

INTEGRAL

80-0093-RevB SRP, DC, NON-ISOLATED, INTERNALLY POWERED, 4-20mA VOLTAGE PULSE OUT

	A	B	C	
RED	1		1	COMM
GREEN	2		2	B+
BLUE	3		3	A-
WHITE	4		4	PULSE OUT +
BLACK	5		5	4-20 mA +
ORANGE	6	VDC GND	6	PULSE - 4-20 mA-

MODBUS C4 C6
10KΩ

Remote

torque all connections to 4-05 to 5-31 In-lbs (0.5 to 0.6Nm). Insulate all connections with heat-shrink tubing. Insulated conductors (75°C).

REMOTE

SAGE PRIME 4-20mA & mA PULSE OUT 24 VDC

Standard PRIMES are shipped with a jumper between pins B4 & B5. This jumper provides +24 VDC to pin B4 to power the 4-20 mA and Pulse outputs. (Note: If isolated 4-20mA and / or pulse output is required, the jumper must be removed. A separate power supply must be used to supply power to pin B4 for these isolated outputs.)

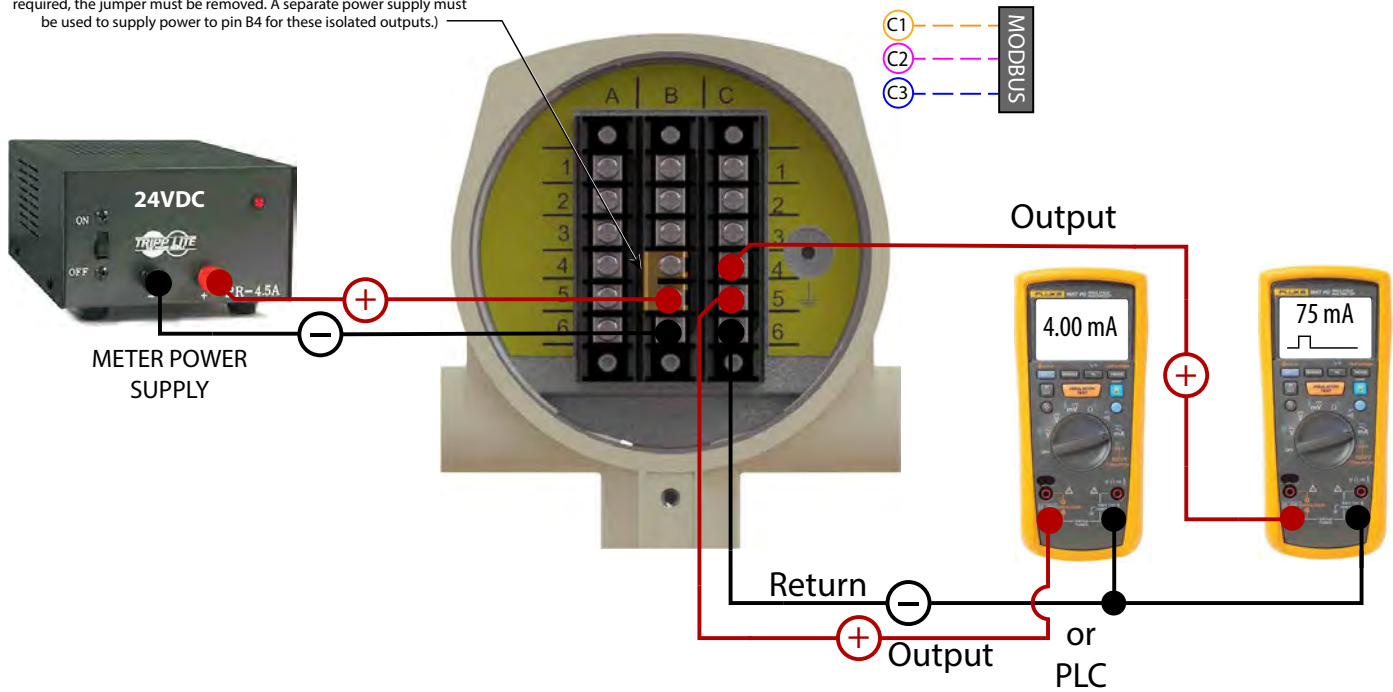

Terminal Block Legend - INTEGRAL

Color	Terminal	Label
RED	1	COMM
S1	2	B+
RED	3	A-
WHITE	4	PULSE OUT +
S2	5	4-20 mA +
WHITE	6	VDC GND
	6	PULSE - 4-20 mA-

80-0125-RevA SIP, DC, NON-ISOLATED, INTERNALLY POWERED, 4-20mA, CURRENT PULSE OUT

INTEGRAL

Terminal Block Legend - REMOTE

Color	Terminal	Label
RED	1	COMM
GREEN	2	B+
BLUE	3	A-
WHITE	4	PULSE OUT +
BLACK	5	4-20 mA +
ORANGE	6	VDC GND
	6	PULSE - 4-20 mA-

80-0126-RevB SRP, DC, NON-ISOLATED, INTERNALLY POWERED, 4-20mA, CURRENT PULSE OUT

REMOTE

SAGE PRIME ISOLATED 4-20mA & VDC PULSE OUT 24 VDC

NOTE: Prime flow meters are shipped with a jumper between B4 and B5 to provide 24VDC for pulse and 4-20mA outputs. This jumper must be removed when using a separate User Power supply for isolation of these outputs.

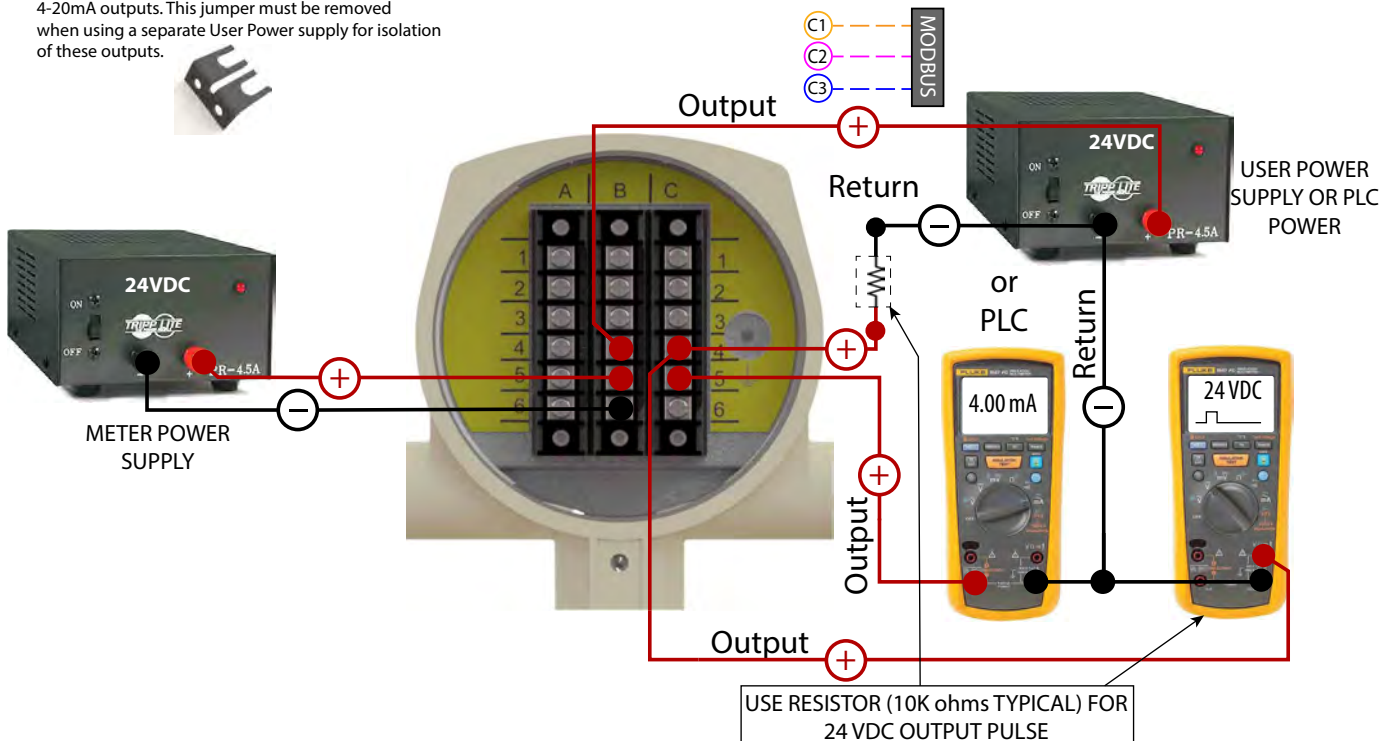

USE RESISTOR (10K ohms TYPICAL) FOR 24 VDC OUTPUT PULSE

Terminal block diagram for the INTEGRAL configuration. The table below shows the wiring for columns A, B, and C.

	A	B	C	
RED	1		1	COMM
S1	2		2	B+
RED	3		3	A-
WHITE	4	Isolated VDC+	4	PULSE OUT +
S2	5	VDC IN	5	4-20 mA +
WHITE	6	VDC GND	6	

Ground side of external power supply is connected to terminal 6. A 10kΩ resistor is connected between terminals 4 and 5. The diagram is labeled "INTEGRAL" and "80-0107-RevB SIP, DC, ISOLATED, EXTERNALLY POWERED, 4-20mA, VOLTAGE PULSE OUT".

INTEGRAL

Terminal block diagram for the REMOTE configuration. The table below shows the wiring for columns A, B, and C.

	A	B	C	
RED	1		1	COMM
GREEN	2		2	B+
BLUE	3		3	A-
WHITE	4	Isolated VDC+	4	PULSE OUT +
BLACK	5	VDC IN	5	4-20 mA +
ORANGE	6	VDC GND	6	

Ground side of external power supply is connected to terminal 6. A 10kΩ resistor is connected between terminals 4 and 5. The diagram is labeled "REMOTE" and "80-0109-RevB SRP, DC, ISOLATED, EXTERNALLY POWERED, 4-20mA, VOLTAGE PULSE OUT".

REMOTE

SAGE PRIME ISOLATED 4-20mA & mA PULSE OUT 24 VDC

NOTE: Prime flow meters are shipped with a jumper between B4 and B5 to provide 24VDC for pulse and 4-20mA outputs. This jumper must be removed when using a separate User Power supply for isolation of these outputs.

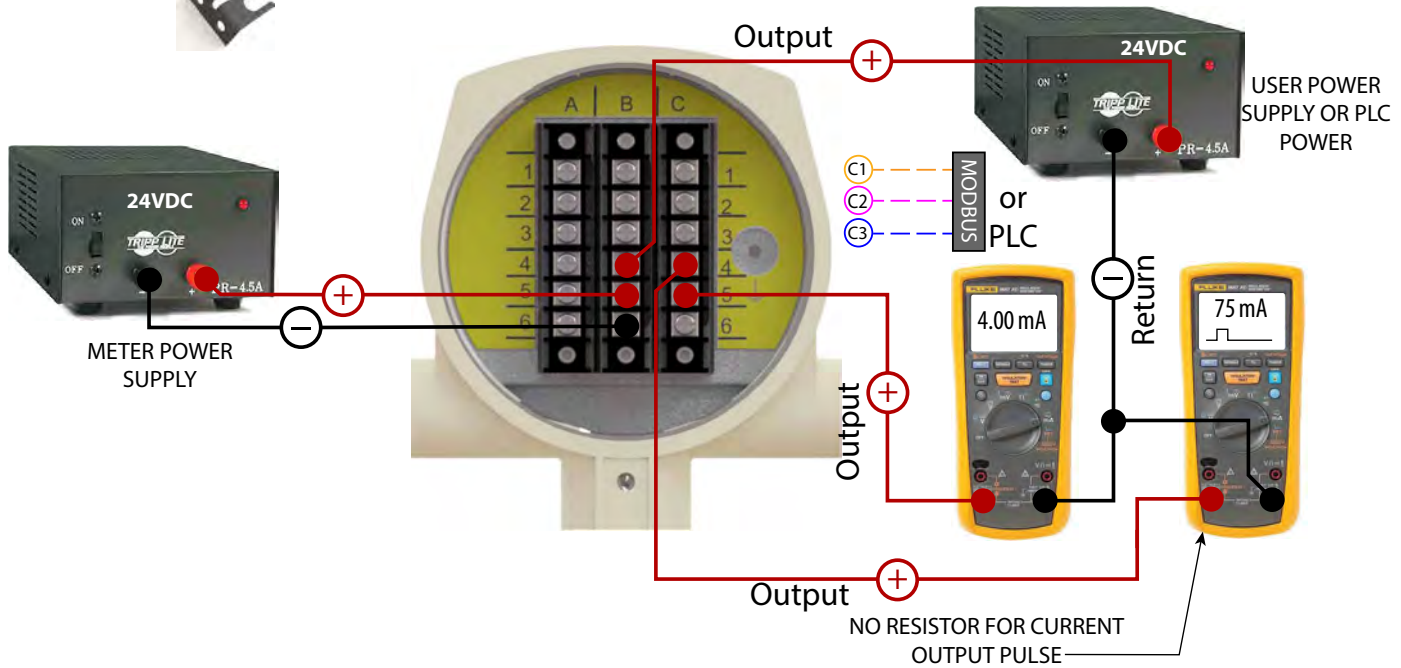

Torque all connections to 4.43 to 5.31 lbf-in. (0.5 to 0.6 Nm). Temperature rating of field installed conductors (75°C).

	A	B	C
RED	1		1 COMM
S1	2		2 B+
RED	3		3 A-
WHITE	4	Isolated VDC+	4 PULSE OUT +
S2	5	VDC IN	5 4-20 mA +
WHITE	6	VDC GND	6

Ground side of external power supply — PULSE — C4

INTEGRAL

80-0127-RevA SIP, DC, ISOLATED, EXTERNALLY POWERED, 4-20mA, CURRENT PULSE OUT

INTEGRAL

Torque all connections to 4.43 to 5.31 lbf-in. (0.5 to 0.6 Nm). Temperature rating of field installed conductors (75°C).

	A	B	C
RED	1		1 COMM
GREEN	2		2 B+
BLUE	3		3 A-
WHITE	4	Isolated VDC+	4 PULSE OUT +
BLACK	5	VDC IN	5 4-20 mA +
ORANGE	6	VDC GND	6

Ground side of external power supply — PULSE — C4

REMOTE

80-0128-RevA SRP, DC, ISOLATED, EXTERNALLY POWERED, 4-20mA, CURRENT PULSE OUT

REMOTE

SAGE PRIME 4-20mA & VDC PULSE OUT 110 VAC

Standard PRIMES are shipped with a jumper between pins B4 & B5. This jumper provides +24 VDC to pin B4 to power the 4-20 mA and Pulse outputs. (Note: If isolated 4-20mA and / or pulse output is required, the jumper must be removed. A separate power supply must be used to supply power to pin B4 for these isolated outputs.)

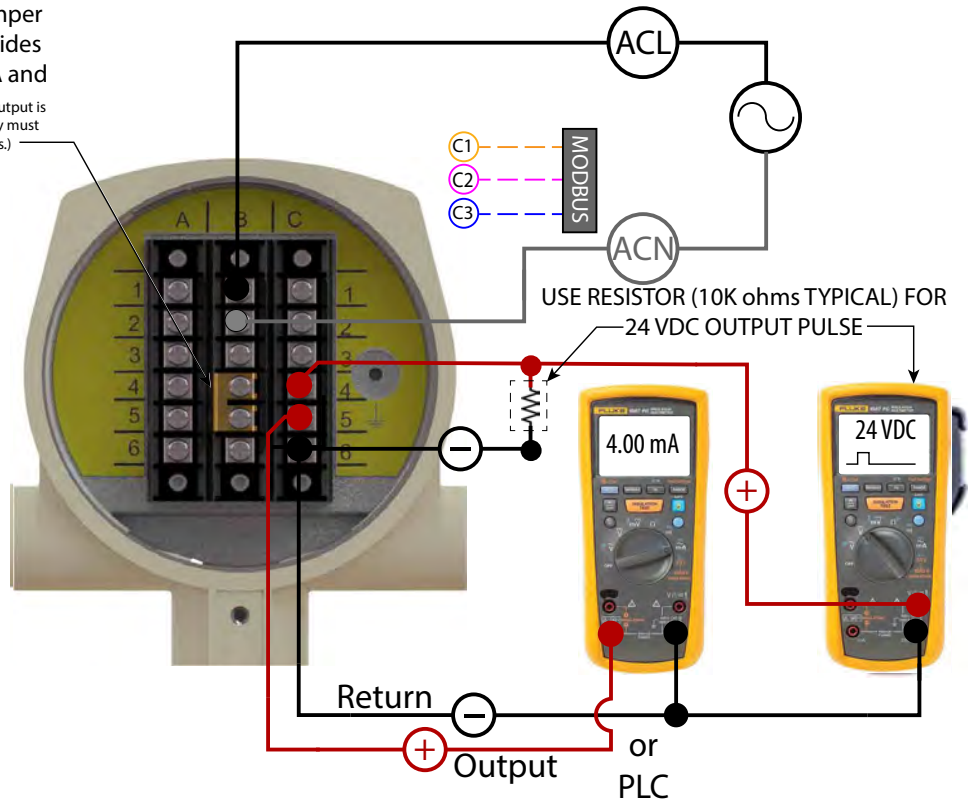

Integral terminal block configuration:

	A	B	C	
RED	1	ACL	1	COMM
S1	2	ACN	2	B+
RED	3		3	A-
WHITE	4	<input checked="" type="checkbox"/>	4	PULSE OUT +
S2	5	<input checked="" type="checkbox"/>	5	4-20 mA +
WHITE	6		6	PULSE - 4-20 mA-

Integral C4 C6 10KΩ

INTEGRAL

Remote terminal block configuration:

	A	B	C	
RED	1	ACL	1	COMM
GREEN	2	ACN	2	B+
BLUE	3		3	A-
WHITE	4	<input checked="" type="checkbox"/>	4	PULSE OUT +
BLACK	5	<input checked="" type="checkbox"/>	5	4-20 mA +
ORANGE	6		6	PULSE - 4-20 mA-

Remote C4 C6 10KΩ

REMOTE

SAGE PRIME 4-20mA & mA PULSE OUT 110 VAC

Standard PRIMES are shipped with a jumper between pins B4 & B5. This jumper provides +24 VDC to pin B4 to power the 4-20 mA and Pulse outputs. (Note: If isolated 4-20mA and / or pulse output is required, a jumper must be removed. A separate power supply must be used to supply power to pin B4 for these isolated outputs.)

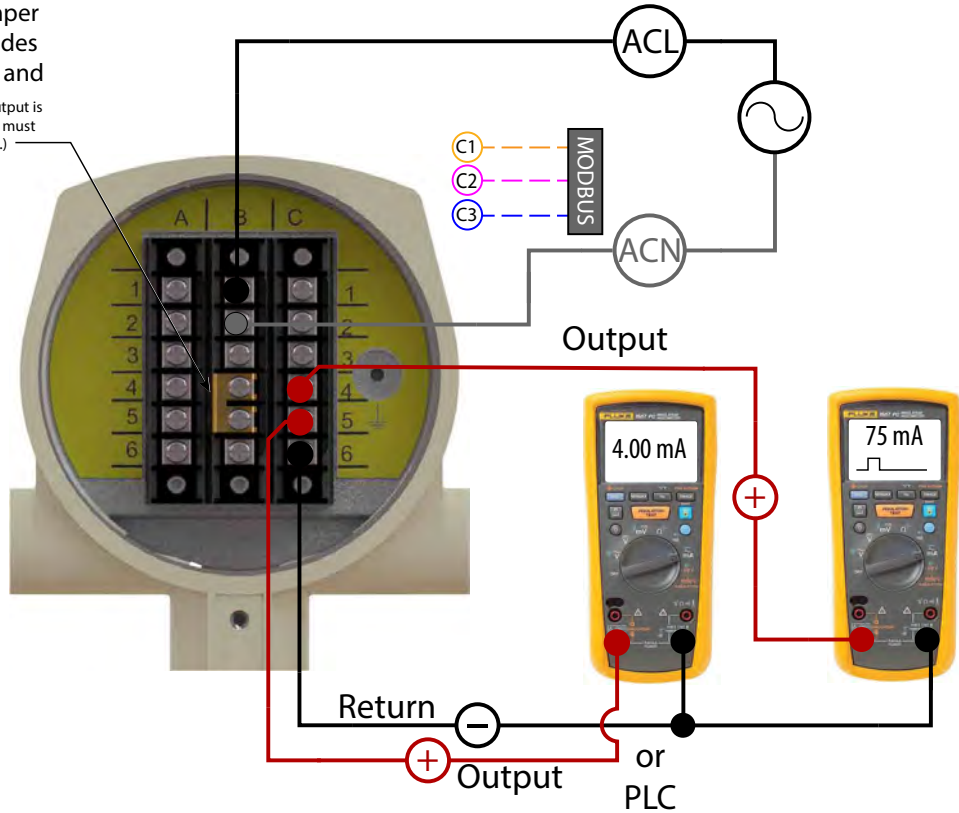

80-0129-RevB SRP.AC.:NON-ISOLATED, INTERNALLY POWERED, 4-20mA, CURRENT PULSE OUT

	A	B	C	
RED	1	ACL	1	COMM
S1	2	ACN	2	B+
RED	3		3	A-
WHITE	4		4	PULSE OUT +
S2	5		5	4-20 mA +
WHITE	6		6	PULSE - 4-20 mA

MODBUS

Integral

80-0129-RevB SRP.AC.:NON-ISOLATED, INTERNALLY POWERED, 4-20mA, CURRENT PULSE OUT

INTEGRAL

80-0130-RevB SRP.AC.:NON-ISOLATED, INTERNALLY POWERED, 4-20mA, CURRENT PULSE OUT

	A	B	C	
RED	1	ACL	1	COMM
GREEN	2	ACN	2	B+
BLUE	3		3	A-
WHITE	4		4	PULSE OUT +
BLACK	5		5	4-20 mA +
ORANGE	6		6	PULSE - 4-20 mA

MODBUS

Remote

80-0130-RevB SRP.AC.:NON-ISOLATED, INTERNALLY POWERED, 4-20mA, CURRENT PULSE OUT

REMOTE

SAGE PRIME ISOLATOR HART ENABLED 24 VDC

Note: Sage Isolator Board provides isolated VDC for isolated 4-20 mA for HART Operation

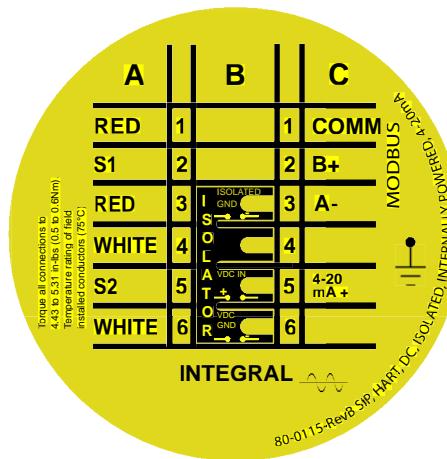
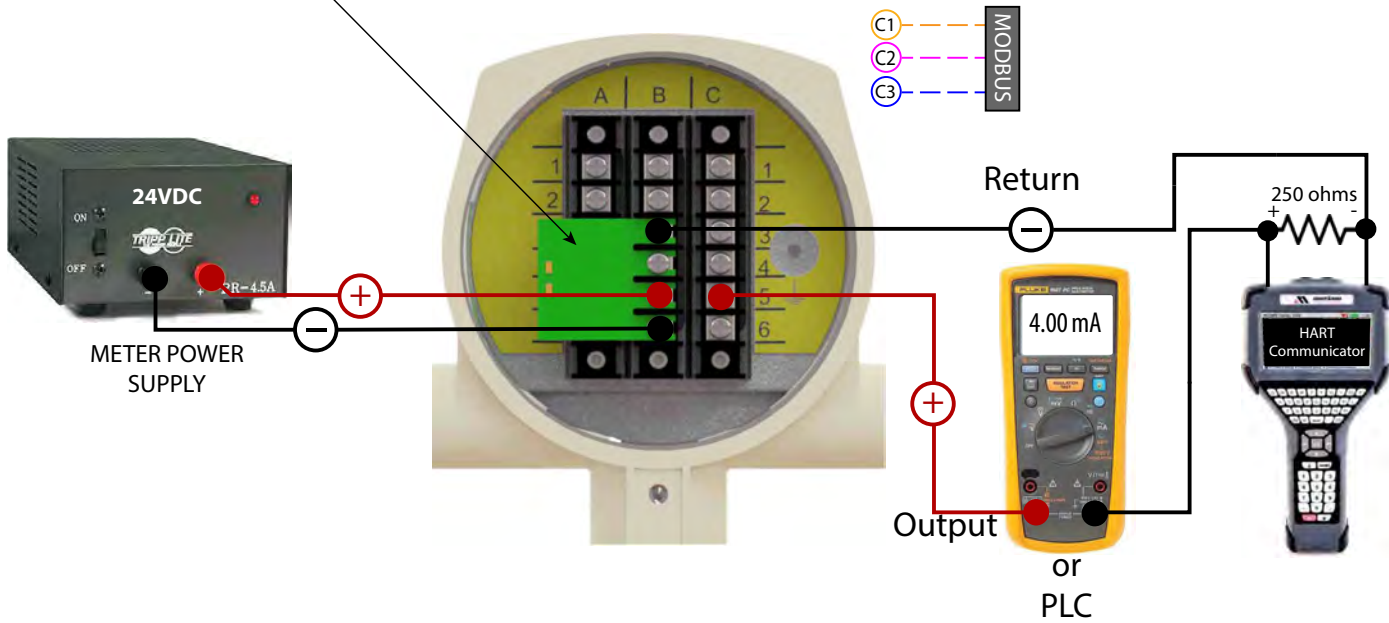

INTEGRAL

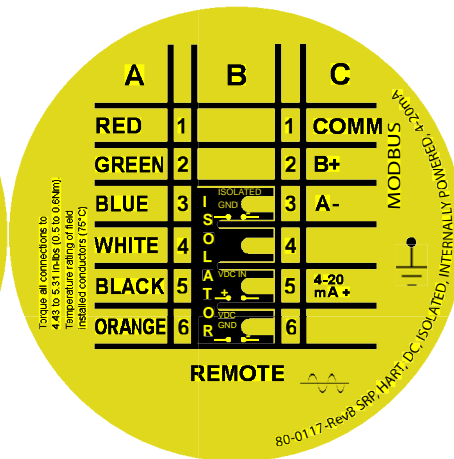

REMOTE

SAGE PRIME ISOLATOR HART ENABLED 110 VAC

Note: Sage Isolator board provides isolated VDC for isolated 4-20 mA for HART Operation

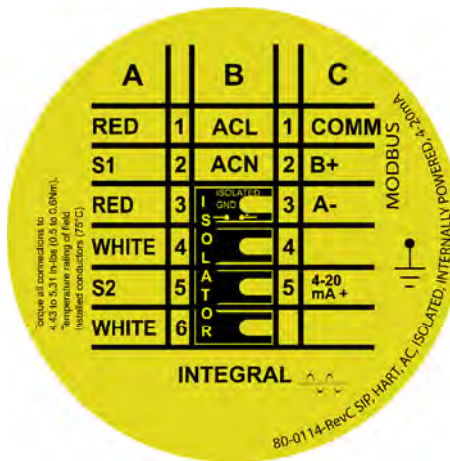
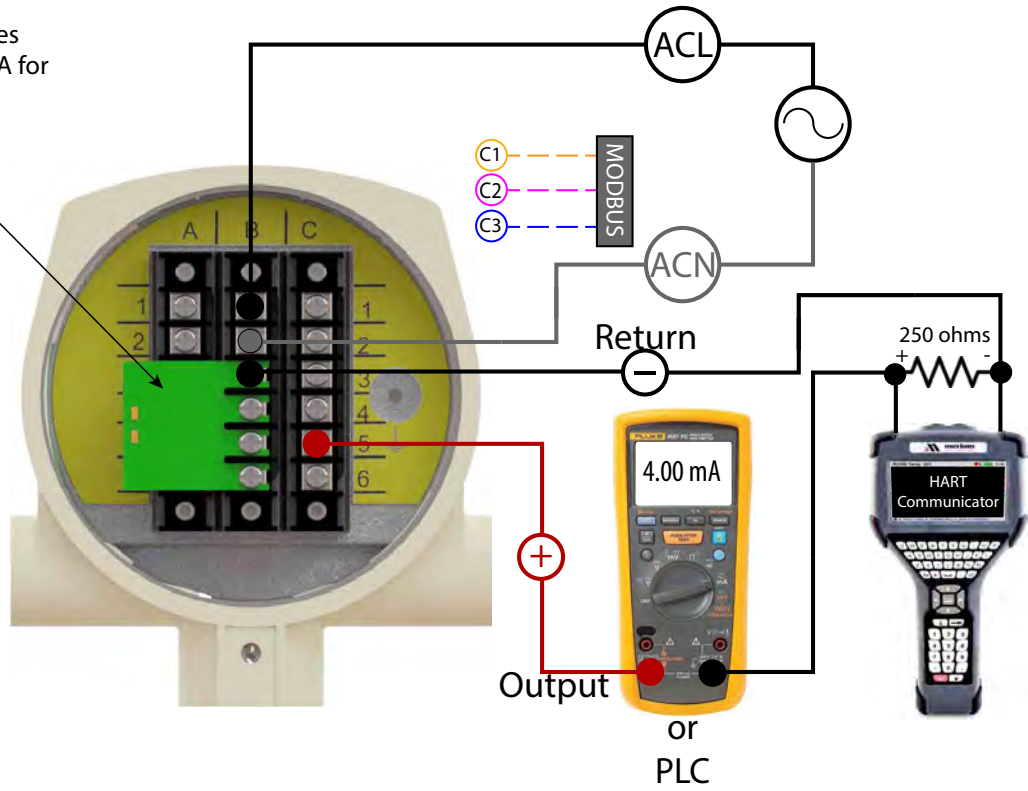

INTEGRAL

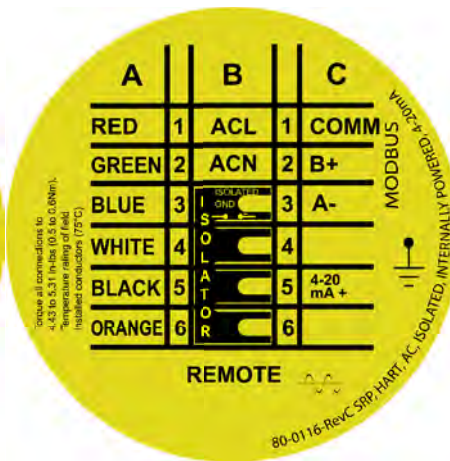

REMOTE

REMOTE CABLE WIRING

Used to connect the main electronics with remote sensor.

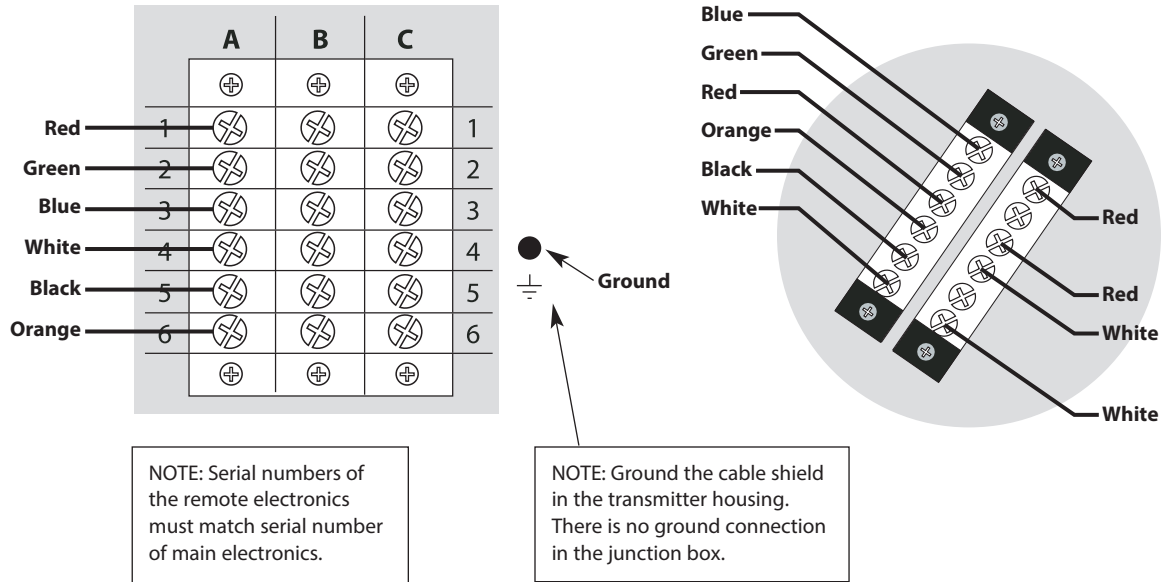

Section

B

STYLES AND FEATURES

Principle of Operation of the Thermal Mass Flow Meter

Sage Thermal Mass Flow Meters have two sensors constructed of reference grade platinum windings (RTDs). The two RTDs are clad in a protective 316SS or Hastelloy C sheath and are driven by a proprietary sensor drive circuit. One of the sensors is self-heated (flow sensor), and the other sensor (temperature/reference sensor) measures the gas temperature. The pair is referred to as the sensing element, and is either installed in a probe as an Insertion style, or inserted into a pipe section as an In-Line style flow meter.

As gas flows by the flow sensor, the gas molecules carry heat away from the surface, and the sensor cools down as it loses energy. The sensor drive circuit replenishes the lost energy by heating the flow sensor until it is a constant temperature differential above the reference sensor. The electrical power required to maintain a constant temperature differential is directly proportional to the gas mass flow rate and is linearized to be the output signal of the meter.

It is essential that this constant temperature differential be maintained, even if there are wide fluctuations in gas temperature. It is the function of the Sage hybrid-digital proprietary sensor drive circuit to maintain the differential, whether or not the gas temperature changes, or however quickly molecules cool off the flow sensor. It is also necessary to properly calibrate the device with the actual gas (or close equivalent with certain gases), in the Sage National Institute of Standards certified (NIST) calibration facility. By accomplishing these two critical objectives, the Sage meters provide an extremely repeatable (0.2% of Full Scale) and accurate output directly proportional to the mass flow rate of the gas being measured.

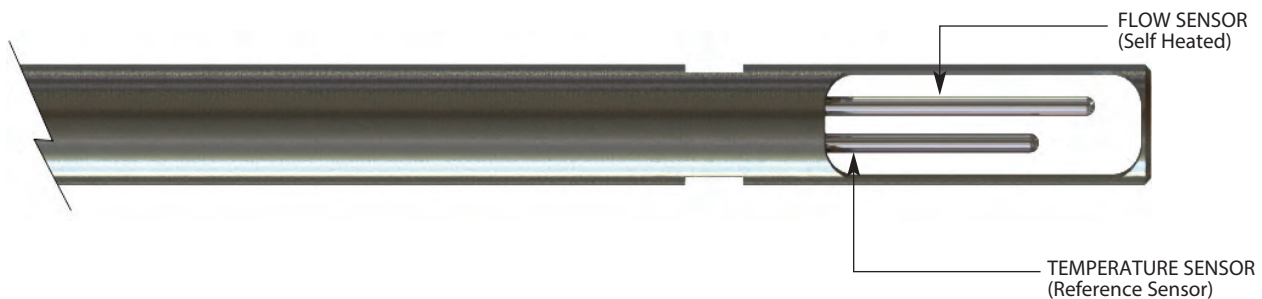

Features and Benefits

SAGE PRIME™ THERMAL MASS FLOW METER FOR GASES

Sage Prime is the top selling meter in our Product Line. The Sage Prime Thermal Mass Flow Meter features a bright, high contrast, photo-emissive OLED (Organic LED) display of Flow Rate, Total and Temperature in a robust, yet lightweight, dual-sided NEMA 4 enclosure. The Flow Rate is also displayed graphically in a horizontal bar graph format. The rear compartment is completely separated from the electronics, and has large, easy-to-access, well marked terminals, for ease of customer wiring (see photo below). It is powered by 24 VDC (12 VDC optional, or 115/230 VAC). The power dissipation is under 2.5 watts (e.g. under 100 mA at 24 VDC).

The Sage Prime Flow Meter is offered in Integral or Remote Style (which has Lead-Length Compensation up to 1000 feet as well as an Explosion Proof Junction Box). Specify any standard probe length or flow body size. It has a 4-20 mA output as well as a pulsed output of Totalized Flow (solid state transistor drive). In addition, Sage Prime supports full Modbus® compliant RS485 RTU communications (IEEE 32 Bit Floating Point) and, optionally, HART™.

Sage Prime is CE approved, and CSA, UL approved for Hazardous Service¹ (see “Approvals” under the “Technology” tab on the website). For ATEX Zone I approvals, request Sage Rio Flyer (SIX Series).

CONTINUOUS DIAGNOSTICS & FIELD CONFIGURABILITY

Sage Prime has continuous diagnostics. The raw calibration milliwatts (mw) is always displayed in the upper left hand corner of the meter’s display. At any time, you can check this reading at a “No Flow” (0 SCFM) condition, and compare the reading to the original reported “No Flow” value noted on the last few lines of your meter’s Certificate of Conformance or the Flow Meter’s data tag. This in-situ diagnostic procedure not only checks the sensor performance and the “Live Zero” calibration point, but it also verifies that the sensor is clean.

It essentially provides a means to validate that the meter is operating properly, verifies that there is no shift or drift, and may eliminate the

need for annual factory calibrations. This simple field diagnostic procedure, in addition, verifies that the sensor is free from contamination, even without inspection.

Although Sage Prime is fully configured upon shipment for the pipe and process conditions requested, if changes are needed, Addresser software is optionally available for field reconfigurability.



MAJOR BENEFITS OF THERMAL MASS FLOW METERS

- Direct Mass Flow – No need for separate temperature or pressure transmitters
- High Accuracy and Repeatability – Precision measurement and extraordinary repeatability
- Turndown of 100 to 1 and resolution as much as 1000 to 1
- Low-End Sensitivity – Measures as low as 5 SFPM (e.g., 1 SCFM in a 6" pipe)
- Negligible Pressure Drop – Will not impede the flow or waste energy
- No Moving Parts – Eliminates costly bearing replacements, and prevents undetected accuracy shifts
- Dirt Insensitive – Provides sustained performance
- Ease of installation and convenient mounting hardware

SPECIFIC BENEFITS OF THE SAGE PRIME

- Features In-Situ “Field Zero Calibration verification” of sensor’s performance – verifies that the sensor is clean, and assures that there is no drift, or shift in the flow meter
- Compact design of enclosure is only 4.6" dia. by 4.5" deep (DC Models)
- High contrast photo-emissive OLED display with numerical Flow Rate, Total and Temperature, as well as Graphical Flow Indicator
- Calibration milliwatts (mW) is continuously displayed, providing for ongoing diagnostics
- Photocell activated Screen Saver to extend display life²
- Proprietary digital sensor drive circuit provides enhanced signal stability and unaffected by process temperature & pressure changes
- Modbus compliant RS485 RTU communications
- HART™ communications (optional)
- Isolated 4-20 mA output and pulsed output of Totalized Flow
- Rugged, user-friendly packaging with easy terminal access
- Option for Solar Energy use (12 VDC models)
- Remote Style has Lead-Length Compensation. Allows remote electronics up to 1000 feet from probe; Explosion Proof Junction Box has no circuitry, just terminals (suitable for harsh environments)
- Low power dissipation, under 2.5 Watts (e.g. under 100 mA at 24 VDC)
- Field reconfigurability via HART or optional Addresser software
- Flow conditioning built into In-Line flow meters (1/2" and up)
- Captive Flow Conditioners for Insertion meter applications, if required

¹ Only available with 24 VDC powered meters

² Note, a built-in photocell continuously monitors the ambient light, and adjusts the display brightness for optimum long-term life

Sage PRIME™ Styles and Specifications

Sage Metering is your source for monitoring, measuring and controlling the gas mass flow in your industrial process, building management system or environmental application. Our high performance, NIST Traceable, Thermal Mass Flow Meters will help increase productivity, reduce energy costs, maximize product yields, and/or help reduce environmental insult. Sage provides high quality In-Line and Insertion Thermal Mass Flow Meters for a wide variety of industrial, commercial, and environmental monitoring needs, including carbon credit verification for Greenhouse Gas

reduction.

Our experienced application engineers, many of whom have worked in the Thermal Mass Flow marketplace since its inception, will assist you in choosing the proper gas Flow Meter for your application – and they will be pleased to offer installation guidance to assure that the meter(s) selected will perform as accurately as possible. Additionally, our Service Staff stand ready to support you with any after-sale assistance that you may require.

SIP SERIES – INTEGRAL

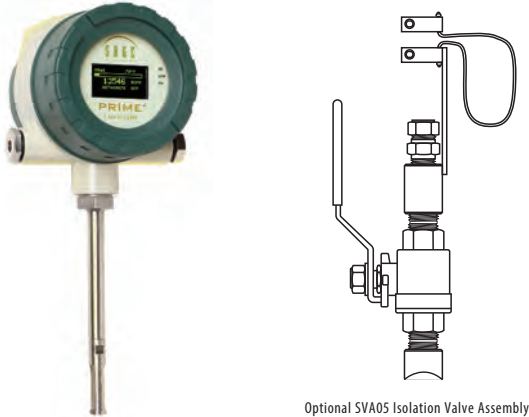

SRP SERIES – REMOTE

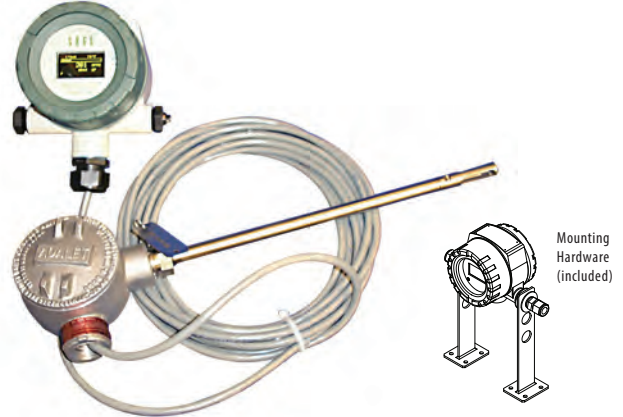

PRIME SIP/SRP

Standard accuracy is +/- 0.5% of Full Scale +/- 1% of reading with a turn-down of 100 to 1 and resolution as much as 1000 to 1. Repeatability is 0.2%. NOTE: Enhanced accuracy optionally available with limited turn-down⁴.

The electronics has an isolated 4 to 20 mA output proportional to Mass Flow Rate as well as pulsed outputs of Totalized Flow (24 VDC solid state transistor drive). In addition, Modbus RS485 RTU communications is available (HART optional).

INTEGRAL STYLE ELECTRONICS

Electronics is Integral Style, with rugged windowed dual compartment NEMA 4 enclosure with local display. The display is a high contrast photo-emissive OLED display with Screen Saver, and it displays Mass Flow Rate, Totalized Flow and Temperature as well as a graphical representation of Flow Rate in a horizontal bar graph format. In addition, the calibration milliwatts (mw) is continuously displayed, providing ongoing diagnostics.

REMOTE STYLE ELECTRONICS

Electronics is Remote Style, with rugged windowed dual compartment NEMA 4 enclosure with display. The display is a high contrast photo-emissive OLED display with Screen Saver, and it displays Mass Flow Rate, Totalized Flow and Temperature as well as a graphical representation of Flow Rate in a horizontal bar graph format. In addition, the calibration milliwatts (mw) is continuously displayed, providing ongoing diagnostics. Includes Remote Mounting Hardware.

The Flow Element's Junction Box is Explosion Proof (Class 1, Div 1, Groups B, C, D), and does not have any electronics – only a wiring terminal block. The Junction Box is connected to the Remote Electronics by 25 feet of lead-length compensated cable. The cable (6-conductor) can be lengthened or shortened without affecting accuracy (max loop resistance 10 ohms, over 1000 feet), if grounded properly.

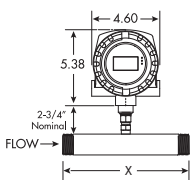

SIP In-Line^{1,3,5}

Flow Element is In-Line Style consisting of a choice of 316 Stainless Steel Schedule 40 Flow Bodies sized from 1/4" x 6" long to 4" x 12" long

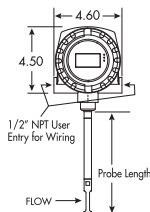

SIP Insertion²

Flow Element is Insertion Style, consisting of a 1/2" OD probe (3/4" optional) with lengths up to 36" long (typically 15" long) suitable for insertion into the center of a process pipe

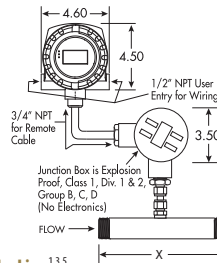

SRP In-Line^{1,3,5}

Flow Element is In-Line Style consisting of a choice of 316 Stainless Steel Schedule 40 Flow Bodies sized from 1/4" x 6" long to 4" x 12" long

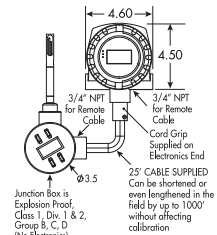

SRP Insertion²

Flow Element is Insertion Style, consisting of a 1/2" OD probe (3/4" optional) with lengths up to 36" long (typically 15" long) suitable for insertion into the center of a process pipe

ENGINEERING SPECIFICATIONS OF OPTIONAL SAGE PRIME PLUS

This is an optional version of Sage Prime offering a separate ground for the 24 VDC Power Supply (optional 5 VDC or 12 VDC Power Supplies) which isolates the Modbus

ground from the power supply ground. All other features of Prime PLUS are identical to the standard Sage Prime, except Approvals do not apply at this time.

- 1 Male NPT ends are standard, with flanged ends, tube, or butt weld optionally available
- 2 Mounting hardware such as Isolation Valve Assemblies, Compression Fittings, and Flanges, are optional
- 3 Chart of Flow Body length "X" is on Application Data Sheet on website as well as on page 40
- 4 Enhanced accuracy available upon request, especially if turndown limited. Contact Sage
- 5 Flow Conditioners are built into In-Line Style Flow Bodies from 1/2" to 4"



Sage PRIME Organic (OLED) Display^{1,2}

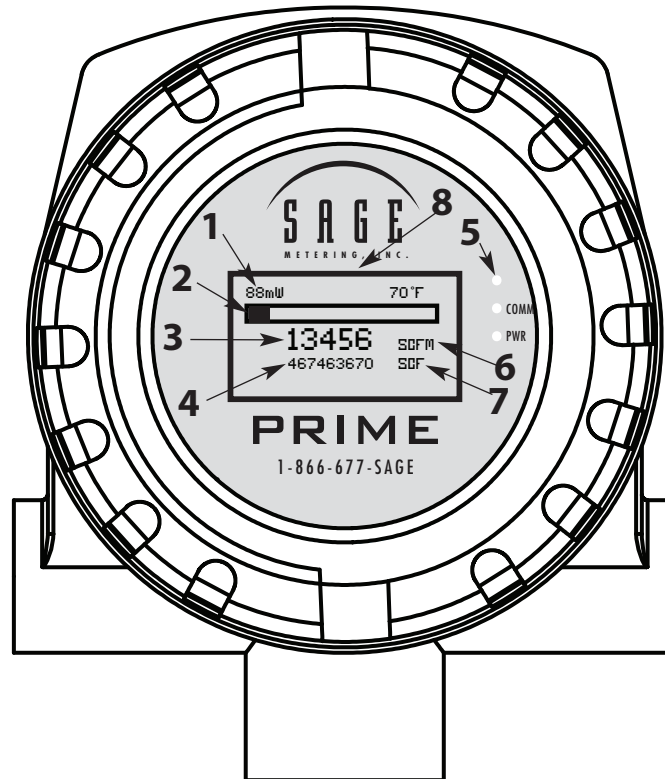

- 1 Raw Calibration milliwatts (mw) for Diagnostics and Periodic "Zero Flow" Calibration Check
- 2 Graphical Indication of Percentage of Full Scale Flow Rate
- 3 Flow Rate
- 4 Totalized Flow (Consumption)
(Value is Retained during Power Outage or Power Cycling)
- 5 Flashes with each pulsed output of consumption
- 6 Engineering Units of Flow Rate (the last digit can be S(seconds), M(minute), H(hour), D(day))
- 7 Engineering Units of Consumption
- 8 Photocell activated Screen Saver extends display life

- 1 Upon start-up, the Revision No., Serial No., and Modbus ID will display for a few seconds. Also the output configurations symbol is momentarily displayed
- 2 Note, a built-in photocell continuously monitors the ambient light, and adjusts the display brightness for optimum long-term life

Approvals ¹

HAZARDOUS LOCATION APPROVALS

All 24 VDC Powered Sage Prime Meters (SIP Integral Insertion, SIP In-Line, SRP Remote Insertion, SRP Remote In-Line) are approved for Class 1, Div 2, Groups B, C, D, T4 and ATEX: Ex nA IIC T4. AC Powered Meters are not approved.

Testing is in accordance with the following Safety Standards:

- ANSI 12.12.01, Electrical Equipment for Use in Class I and II, Division 2, and Class III Hazardous (Classified) Locations
- CSA C22.2 No. 213-M1987 (R1999), First Edition, Non-incendive Electrical Equipment for Use in Class I, Division 2 Hazardous Locations
- UL/CSA 61010-1, Second Edition, Safety Requirements for Electrical Equipment for Measurement, Control, and Laboratory Use – Part 1: General Requirements

The following is required to comply with the above mentioned Approvals

- 1) Repair of the product (or replacement of components) is not possible by the user
- 2) As noted on the following label (see below) it will contain the following markings: Ex symbol, nA symbol IIC, temperature class
- 3) All Prime 24 VDC meters will be marked with “X” which means that these Special Conditions of Use will apply:
 - a) The completed meter must be installed with a rigid or flexible metal conduit in order to satisfy approval conditions.
 - b) The meter has been approved for use with the electronics enclosure in an ambient temperature from – $40^{\circ}\text{C} < T_a < 65^{\circ}\text{C}$.

- 4) Sage Metering considers a linear correction suitable for temperatures exceeding the temp code rating of 40C (104F) thus no customer correction is needed.



CE CONFORMANCE

All AC & DC Powered Sage Metering, Inc. Series SIP (Sage Prime-Integral) and Series SRP (Sage Prime-Remote) are CE Compliant for the following CE directives:

- EN61000-6-4 for Electromagnetic compatibility;
- EN61000-3-2 for Harmonics;
- EN61000-3-3 for Flicker;
- EN61000-6-2 for Electromagnetic Compatibility (Immunity for Industrial Environments), which includes EN61000-4-2 for ESD;
- EN61000-4-3 for Radiated Immunity;
- EN61000-4-4 for EFT/B; EN61000-4-5 for Surge;
- EN61000 for Conducted Immunity;
- EN61000-4-8 for Magnetic Immunity;
- EN61000-4-11 for Voltage Interruptions

CE MEDICAL CONFORMANCE

Contact Sage Metering if Medical CE Conformance is required. (AC Powered Sage Prime Meters only.)
The Standard is to IEC 60601-1-2:2007 Edition 3

¹ CRN approval optional on certain models. Contact Sage.

Section

C

DRAWINGS

SIP Series Integral Style Mass Flow Meters

IN-LINE STYLE^{1,3}

150#, 300#, or 600# flanged ends are optionally available. (150# flanges recommended on 3" and 4" Flow Bodies)

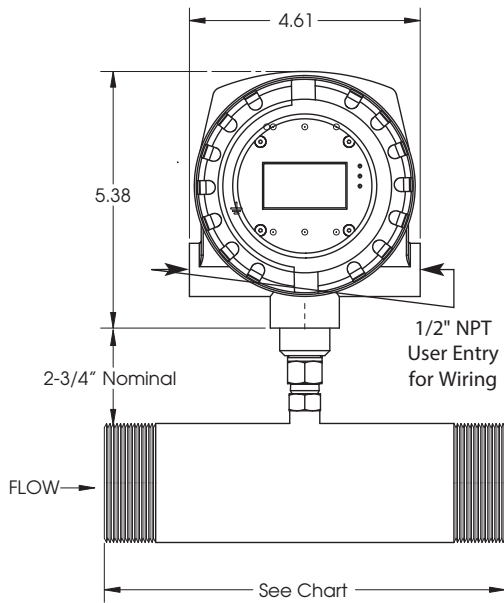

CAUTION:
Do not rotate the Enclosure of In-Line Style Meters relative to the Flow Tube, or the calibration may be effected since the sensors may become misaligned.

IN-LINE METER DIMENSIONS

Pipe Size x Flow Body Length (B) ³
1/4" x 6"
3/8" x 6"
1/2" x 7"
3/4" x 7"
1" x 8"
1-1/4" x 10"
1-1/2" x 12"
2" x 12"
2-1/2" x 12"
3" x 12"
4" x 12"

Depth: DC Enclosure depth is 4.35"
AC Enclosure depth is 5.35"

INSERTION STYLE²

150#, 300#, or 600# flanged mounting is optionally available. Available probe lengths are 6", 12", 15", 18", 24", 30", 36" or 48". Standard probe is 1/2" diameter (3/4" optional – recommended for 36" or 48")

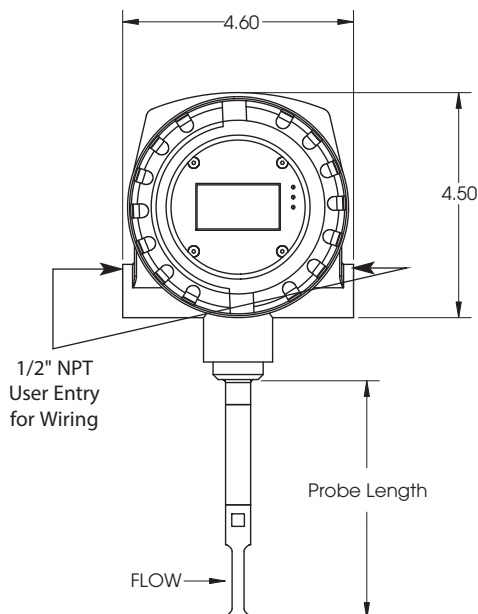

1 NPT Fittings standard
2 Flanged Mounting available for high pressure operation
3 Flow Conditioning built in to Flow Meter Pipe Sizes 1/2" and up. Contact Sage for optional 1/4" tube flow body.

SRP Series Remote Style Mass Flow Meters

IN-LINE STYLE^{1,3,4}

150#, 300#, or 600# flanged ends are optionally available. (150# flange recommended on 3" and 4" Flow Bodies)

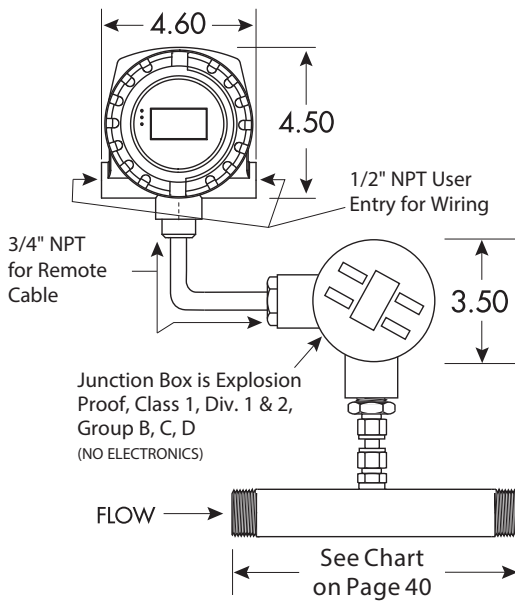

CAUTION: Do not rotate the Junction Box of In-Line Style Meters relative to the Flow Tube, or the calibration may be effected since the sensors may become misaligned.

INSERTION STYLE²

150#, 300#, or 600# flanged mounting is optionally available. Available probe lengths (C) are 6", 12", 15", 18", 24", 30", 36" or 48".

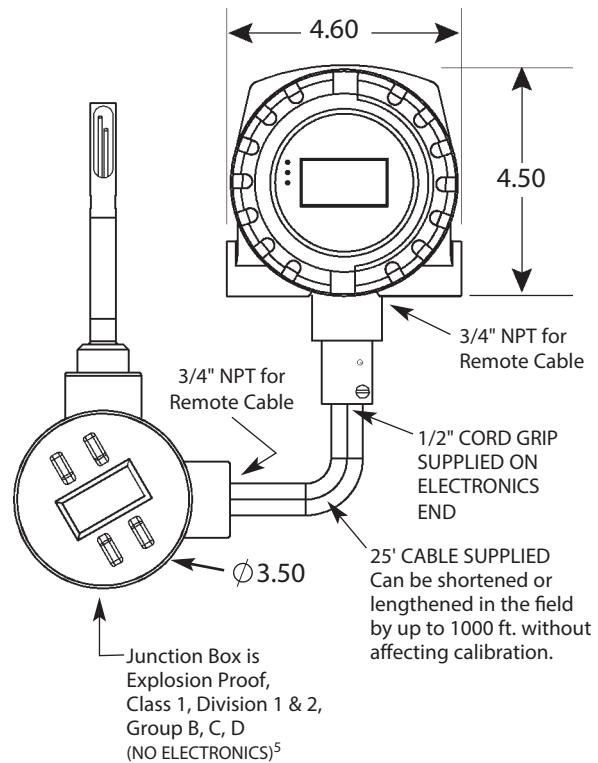

¹ NPT Fittings standard

² Flanged Mounting available for high pressure operation

³ Flow Conditioning built in to Flow Meter Pipe Sizes 1/2" and up. Contact Sage for optional 1/4" tube flow body.

⁴ See Chart on page 40.

⁵ Junction Box has the following certifications: Class I, Groups B,C,D; Class II, Groups E,F,G; Class III; 4X, 7BCD, 9EFG; FM Standard 3615; UL Standard 1203; CSA Standard C22.2 No. 30; and NEMA Compliance

Sage Prime Remote Bracket Layout

MOUNTING OPTIONS

1. Overhead with U-bolts (customer supplied) across pipe on each leg
2. Vertically, as shown
3. Horizontally

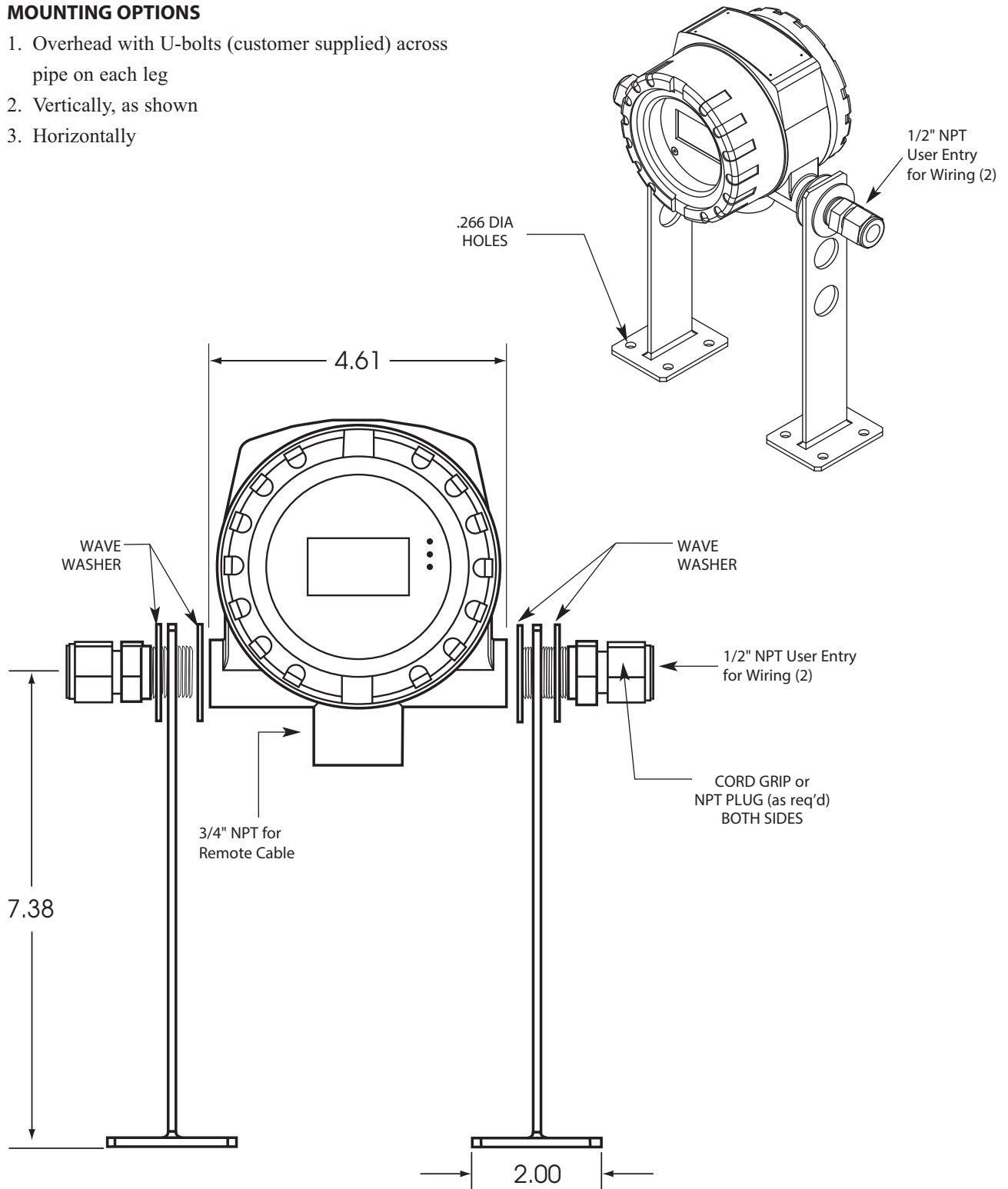

1/2" Mounting Hardware^{1, 2, 3, 4, 6, 7}

SVA05 SERIES ISOLATION VALVE ASSEMBLY FOR INSERTION METERS⁴

(for Low Pressure SVA05 see page 46)

Used for pressures to 250 psig¹ (shown for use with 1/2" diameter insertion meters). 150# or 300# flanged mounting is optionally available. 1/2" x 3/4" NPT (SVA05 shown).

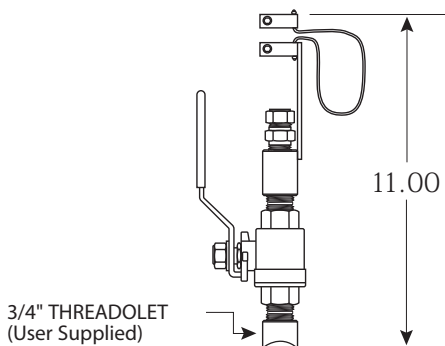

NOTE: User needs to weld a 3/4" female threadolet (of appropriate radius) to mate with existing pipe after a 3/4" hole has been drilled in pipe. The 3/4" Male Coupling of the Sage Isolation Valve Assembly will thread into the user's 3/4" threadolet.

PROBE LENGTH (with sensor)	SAFETY CHAIN LENGTH ²
12"	8.25"
15"	11.25"
18"	14.25"
24"	20.25"

SVA05 SERIES ISOLATION VALVE ASSEMBLY DETAIL⁵

Cut away view of probe inserted through isolation ball valve assembly.

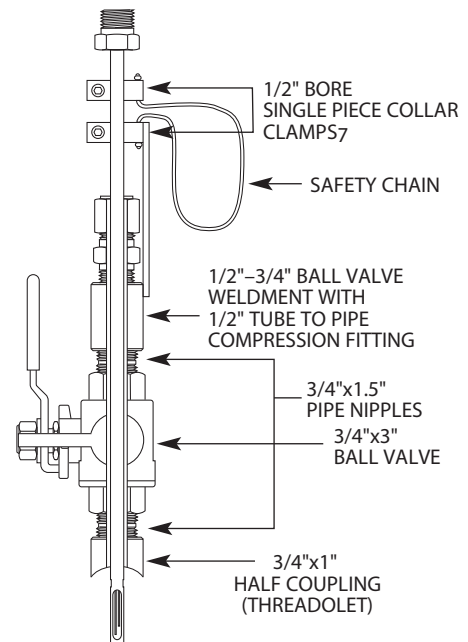

STCF SERIES TEFLON FERRULE COMPRESSION FITTING

1/2" tube x 1/2" pipe fitting (shown, not to scale), is used for low pressure insertion applications to 125 psig (Stainless Steel Ferrule optional for higher pressure applications – up to 225 psig). Also available in 3/4" tube x 3/4" pipe size.

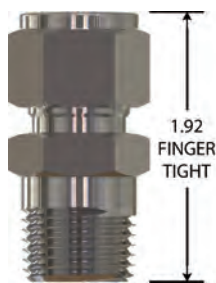

MOUNTING PLATE FOR THIN WALLED DUCTS (INCLUDES STCF05 COMPRESSION FITTING)

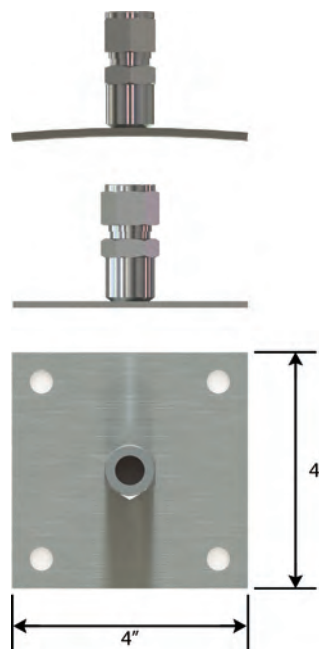

1 At 250 psig, force exerted on 1/2" diameter probe is 50 lbs
 2 Safety chain is designed to prevent probe from accidentally escaping from assembly during removal from pressurized pipe
 3 Insertion meters can have optional flanged mounting (generally used for high pressure or very hot gases). This adaptation is not shown. Consult factory for details.
 4 Maximum gas temperature, 200F, unless high temperature models ordered.
 5 Hot Tapping is feasible by removing Weldment (upper portion of assembly temporarily removed)
 6 See page 54. SVA05 can be utilized for Sensor Functionality and Zero Self Check.
 7 The allen wrench for SVA05 is 3/8" (it is 1/2" for SVA07).

3/4" Mounting Hardware^{1,3}

SVA07 SERIES ISOLATION VALVE ASSEMBLY FOR INSERTION METERS⁴

Used for pressures to 125 psig¹ (shown for use with 3/4" diameter insertion meters). 150# or 300# flanged 3/4" x 1" NPT for use with 3/4" diameter insertion meters (SVA07 shown).

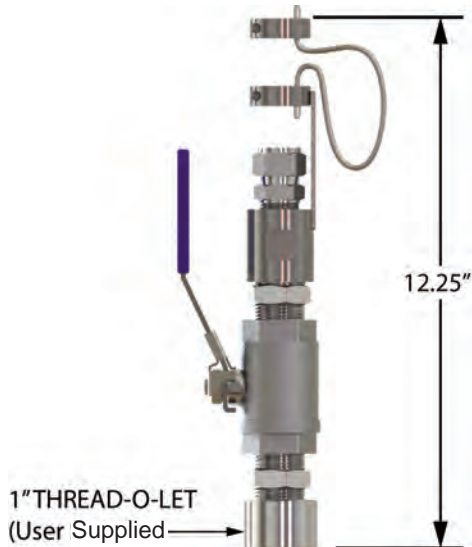

Note: User needs to weld a 1" female threadolet (of appropriate radius) to mate with existing pipe after a 1" hole has been drilled in pipe. The 1" Male Coupling of the Sage Isolation Valve Assembly will thread into the user's 1" threadolet.

STCF SERIES TEFLON FERRULE COMPRESSION FITTING

3/4" tube x 3/4" pipe fitting (shown, not to scale), is used for low pressure insertion applications to 125 psig (Stainless Steel Ferrule optional for higher pressure applications – up to 225 psig). Also available in 3/4" tube x 3/4" pipe size.



SVA07 SERIES ISOLATION VALVE ASSEMBLY DETAIL²

Cut away view of probe inserted through isolation ball valve assembly.

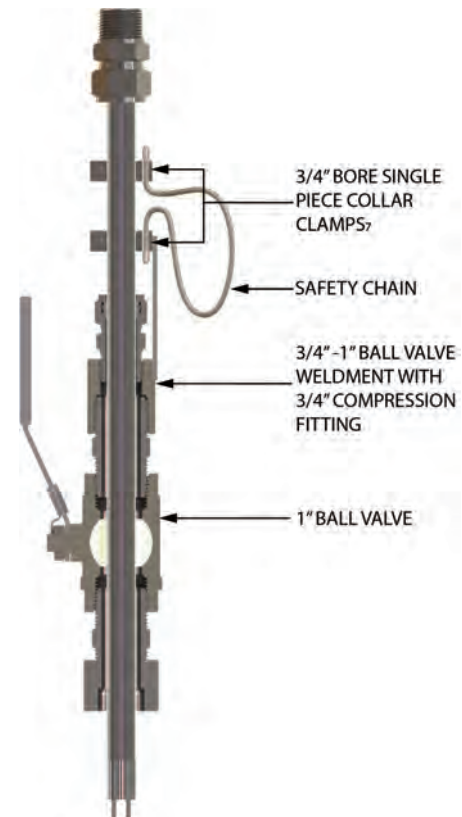

PROBE LENGTH (with sensor)	SAFETY CHAIN LENGTH ²
12"	8.25"
15"	11.25"
18"	14.25"
24"	20.25"

¹ Safety chain is designed to prevent probe from accidentally escaping from assembly during removal from pressurized pipe

² Hot Tapping is feasible by removing Weldment (upper portion of assembly temporarily removed)

³ See page 53. SVA07 can be utilized for Sensor Functionality and Zero Self Check.

SVA05LP Low Pressure Isolation Valve Assembly

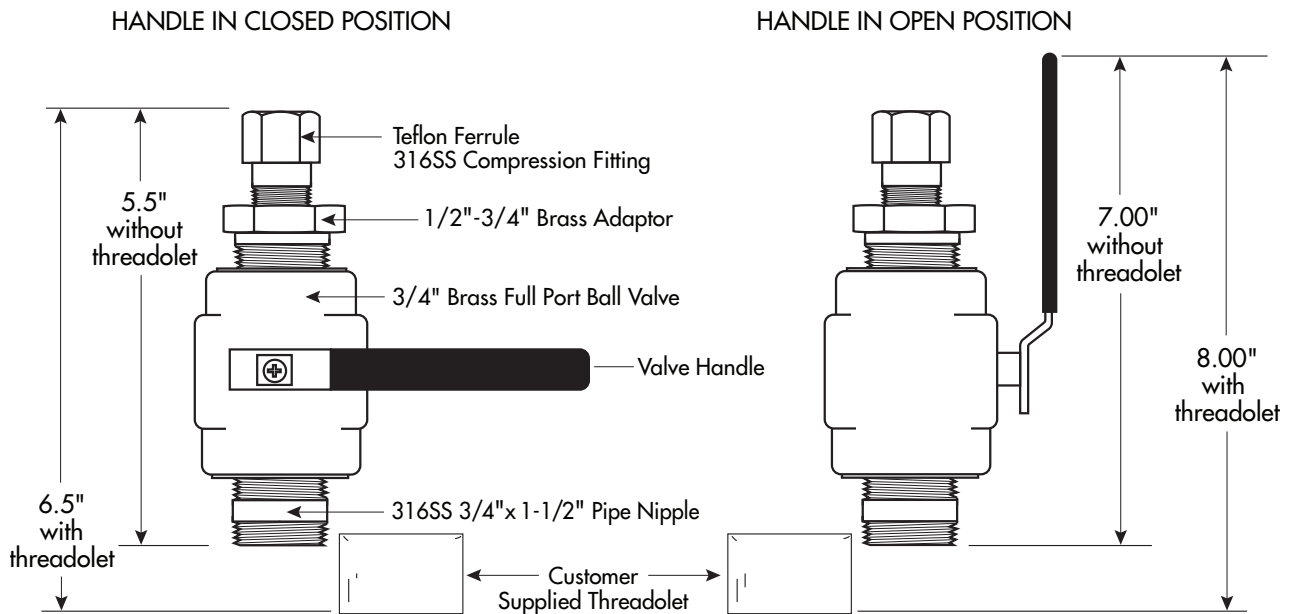

NOTES AND CAUTIONS

- Suitable for low pressure Air or Natural Gas applications (maximum 50 PSIG)
- Assumes 1/2" Insertion Probe inserted to center of a Pipe (see Sage Probe Insertion Guidelines)
- Teflon Ferrule permits ease of Probe insertion or removal
- Exercise caution when loosening Ferrule nut during insertion and removal of Probe, since this model has no Safety Chain
- Note, maximum upward force is 20% of pipe pressure (i.e., 10 Lbs with 50 PSIG)
- The Assembly will be shipped with a plastic sleeve that protects the 3/4" pipe nipple
- It is the Customer's responsibility to weld a Female Threadolet with correct diameter to pipe

Flanged Ends for In-Line Meter (OPTIONAL)

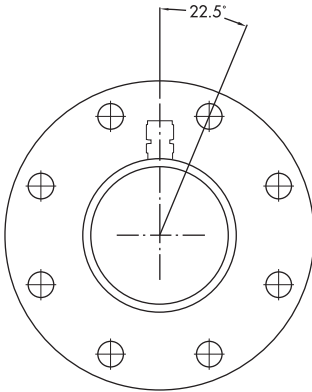

Flanges for 3½" pipe sizes and up,
have 8 bolt holes

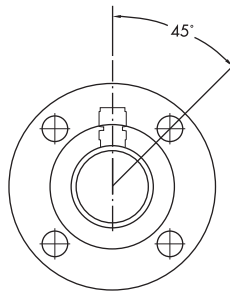

Flanges for 3" pipe sizes and
smaller have 4 bolt holes

Flanged Mounting for Insertion Meter (OPTIONAL)

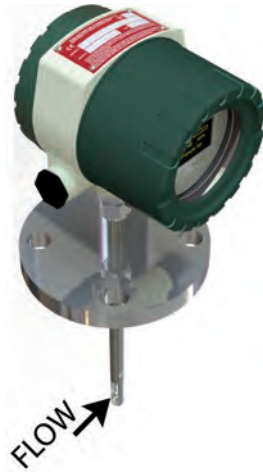

Section

D

DIAGNOSTICS

Common Diagnostics

SYMPTOM: Display failure, or pixels extremely dim.
CORRECTIVE ACTION: Contact Factory. Certain types of failures are under long term warranty. Please note that the 4-20 mA will still function normally.

SYMPTOM: Display fading, or partially fading.

CORRECTIVE ACTION:

- a) Some fading, particularly with those characters that are lit up most frequently, is normal. The flow meter will continue to function properly, and flow meter accuracy and outputs will not be effected.
- b) In extreme cases, contact the factory for display replacement.
- c) Note, in late 2009, the Sage Prime was modified to incorporate a built-in photocell. The purpose of the photocell is to adjust the display brightness with ambient lighting. The brighter the surrounding lighting conditions, the brighter the display. Lower ambient lighting conditions, such as a factory environment, will dim the display. The display will be dimmest if operated in low ambient lighting, or at night. The photocell circuit is designed to extend the life of the display, and to minimize fading.
- d) Note, in early 2010, a further enhancement was added to further extend the life of the display. The above mentioned built-in photocell also senses motion which automatically switches display from Screen Saver mode to Normal mode.
- e) Screen Saver mode disabled starting in 2016

SYMPTOM: Erratic Readings.

POSSIBLE CAUSES: If a large Motor or Generator or Variable Frequency Drive (VFD) is nearby the enclosure, it may be inducing sufficient analog noise into the circuitry to temporarily corrupt the data.

SUGGESTED CORRECTIVE ACTION:

- a) If a Power-Restart temporarily solves the problem, than it is likely that the source of the noise was the problem.
- b) To prevent subsequent problems, if a Remote Style Meter, move the enclosure as far away as possible from the source (the Motor or VFD).
- c) If an Integral Style Meter, mount the meter in a different location (further from the source) or move the source further from the meter.

SYMPTOM: Erratic Readings on a Remote Meter.

POSSIBLE CAUSE: In some cases, analog noise is induced into the Remote cable causing erratic, or climbing readings.

SUGGESTED CORRECTIVE ACTION:

- a) Be sure the remote cable is installed in metal conduit and grounded on the transmitter end only.
- b) Also, avoid coiled cable, especially if not in metal conduit.
- c) Also, if extra cable exists, move the extra cable as far away as possible from any source of analog noise, such as large motors or VFDs.

SYMPTOM: Meter reading zero continuously, or Full Scale continuously, or temperature reading is abnormally low (hundreds of degrees below zero).

POSSIBLE CAUSES/SUGGESTED CORRECTIVE ACTION:

- a) It is likely that a wire is loose. But in rare cases, a sensor could fail (i.e., if a standard sensor, HT01 or HT02 sensor exceeds a process temperature of 450°F.)
- b) Check for continuity to be sure the wiring is making good contact at the terminals of the Junction Box.
- c) Also, to verify that the electronics and the sensor serial number are the same, note the following: The sensor's serial number will come up upon power up, right after Initializing on the Display. If the serial number doesn't agree with the Junction Box labels, that would affect calibration (in other words, sensors and electronics are a matched pair—mixing them up will cause false readings). Also metal Serial Number Tags are fastened to both the electronics and the Junction Box. They must have identical Serial numbers.
- d) To check if a sensor has failed on a remote style meter, it is easy to use the Junction Box to do so. You must Power Down (shut off power), but you do not need to remove the probe from the pipe. Refer to page 29.

- e) An Ohm Meter is required to check across the sensor leads of the Flow Sensor. Look at the drawing of the Junction Box. Disconnect the red wires on the Factory Side to isolate and measure the resistance. If the reading is infinity or a short, it means that sensor has failed.
- f) Now check the Temperature Sensor. Disconnect the white wires on the Factory Side to isolate and measure the resistance. If you have infinity or a short, it means that sensor is burned out. Note: Normally the sensors will read approximately 110 ohms at 70° F. At higher temperatures they should read a higher resistance, but both sensors should have a similar value.
- g) On integral style meters (SIP), there is no Junction Box. In that case, refer to the Prime Integral Terminals on page 26 and check the sensor wires. Remove the appropriate wires first (red pair for flow, then white pair for temperature). Measure their resistance. If reading infinity or short, it means that sensor has failed.
- SYMPTOM:** Meter Railing (Pegging) or Reading High
POSSIBLE CAUSES/SUGGESTED CORRECTIVE ACTION:
- a) Insufficient straight run (i.e. flow profile is disturbed, causing errors).
- b) Possible jet effect if upstream pipe is smaller than meter flow body or if valve is too close upstream to meter.
- c) Not following Probe Insertion Guideline.
- d) If sensor is inserted in reverse (“Upstream” mark is facing downstream) Meter may over-report (or under-report) by as much as 30%.
- e) If sensor is not aligned properly, with “Upstream” mark facing upstream, a rotation greater than ± 5 degrees may cause change in reading (greater than ± 5 degrees and less than ± 20 degrees causes meter to over-report; a greater rotation actually blocks the sensor, and causes meter to under-report).
- f) A downstream valve too close to the meter (flow may be reflecting back).
- g) Possibly caused by water droplets condensing out of gas stream (which generally causes output to spike; but if droplets are near continuous, output may rail).
- h) Meter is miswired, especially in Remote Style application.
- i) Possibly caused by water droplets condensing on inside of pipe wall, which roll down or hit sensor causing output to spike; but if droplets are near continuous, output may rail. Note: Recommend installation 45° from vertical (see drawing on page 81).
- j) Possibly caused by water droplets condensing out of gas stream and filling the cavity containing the sensing elements (usually due to probes mounted below horizontal in saturated pipes).
- k) Sensor may be contaminated. Remove probe, wipe off or clean with a solvent. Reinsert.
- l) Using a different gas or gas mix than the meter was specified and calibrated for.
- m) If a Remote Style Meter (SRP), be sure Serial Numbers of Junction Box and Remote Electronics are identical (if not, errors in calibration are inevitable). To confirm, verify that Junction Box Serial Number Tag has identical Serial Numbers to Tag on Remote Enclosure.
- n) Meter may appear to be reading high if user is comparing Sage flow meter readings (SCFM) to an uncorrected volumetric device (ACFM). For example, at constant volume, a decrease in gas temperature will increase the mass flow (SCFM). That is completely normal.
- SYMPTOM:** Reading Low
POSSIBLE CAUSES:
- a) Insufficient straight run (i.e. flow profile is disturbed, causing errors).
- b) Poor flow profile Upstream (insufficient upstream straight run).
- c) Not following Probe Insertion Guideline.
- d) If sensor is inserted in reverse (“Upstream” mark is facing downstream) Meter may over-report (or under-report) by as much as 30%.
- e) If sensor is not aligned properly, with “Upstream” mark facing upstream, a rotation greater than ± 5 degrees may cause change in reading (greater than ± 5 degrees and less than ± 20 degrees causes meter to over-report; a greater rotation actually blocks the sensor, and causes meter to under-report).

- f) Sensor may be contaminated. Remove probe, wipe off or clean with a solvent. Reinsert.
- g) Using a different gas or gas mix than the meter was specified and calibrated for.
- h) If a Remote Style Meter (SRP), be sure Serial Numbers of Junction Box and Remote Electronics are identical (if not, errors in calibration are inevitable). To confirm, verify that Junction Box Serial Number Tag has identical Serial Numbers to Tag on Remote Enclosure.
- i) Meter may appear to be reading low if user is comparing Sage flow meter readings (SCFM) to an uncorrected volumetric device (ACFM). For example, at constant volume, an increase in gas temperature will lower the mass flow (SCFM). That is completely normal.
- j) On most models, the Totalizer will not start counting for 10 seconds after power up so any flow data will not be accumulated during this time.
- k) Insufficient power supply—most products require minimum 100 mA.
- l) Excessive load on the 4-20 mA. (To check if problem is due to 4-20 mA output device, temporarily remove device, and observe if display reads as expected).

SYMPTOM: Totalizer can take up to 10 seconds to update its reading when flow meter is first powered up, or a channel is changed.

CORRECTIVE ACTION: None. This slight delay is completely normal.

SYMPTOM: Display does not have power

POSSIBLE CAUSE: Mis-wiring

SYMPTOM: 4-20 mA output not tracking the flow rate display

POSSIBLE CAUSE:

- a) In normal operation (Self Powered) B4 and B5 must be jumpered to supply power to loop. See page 21 and 22.
- b) In Externally Powered mode, the jumper must be removed. Verify that 9 to 27 Volts DC is supplied to externally power the loop as per page 20 and pages 27 and 28 for units with HART.

SYMPTOM: 4-20 mA output always at 4 mA. Unit has HART communications.

POSSIBLE CAUSE: Poll address is not set to 0.

In-Situ Verification Procedure

RECOMMENDED AT LEAST ANNUALLY TO COMPLY WITH EPA 40 CFR 98 PERIODIC CALIBRATION VERIFICATION, CAR¹ PROTOCOLS, AND CDM² PROTOCOLS

Sage Prime has continuous diagnostics. The raw calibration milliwatts (mW) is always displayed in the upper left hand corner of the meter's display allowing the user to conduct an "in-situ" calibration verification. At any time, you can check this reading at a "no flow" condition and compare the reading to the original reported "zero flow" value noted on the last few lines of your meter's Certificate of Conformance or the flow meter's data tag. This diagnostic procedure not only checks the sensor performance and the "live zero" calibration point, but it verifies that the sensor is clean. It essentially provides a means to validate that the meter is operating properly, verifies that there is no shift or drift, and may eliminate the need for annual factory calibrations. This simple field diagnostic procedure also verifies that the sensor is free from contamination, even without inspection.

1. Verify that meter has no gas flow³
Close appropriate valves in the process to have a "no flow" condition so you can check the "live zero" mW output of the actual gas (it should be checked at the same pressure as noted on Certificate of Conformance).
If it is not possible to close valves in the process (e.g. natural gas supply must be kept flowing), a user with a Sage SVA05 or SVA07 Isolation Valve Assembly can check "zero" of the actual gas and pressure without shutting off the gas supply. Refer to SVA SERIES ISOLATION VALVE ASSEMBLY DETAILS in the Sage User Manual.
 - a) Loosen lower Collar Clamp completely⁴
 - b) Slightly loosen compression fitting until Probe can be lifted
 - c) Lift Probe until Safety Chain is taut
 - d) Tighten compression fitting
 - e) Close Valve
 - f) Check zero mW as per "2" below
 Optionally, do an ambient air check by removing probe and covering up sensor by capping the sensor with a plastic bag, empty plastic water bottle or other means of preventing flow (see 8).
2. Observe the raw mW on the top of the meter's display. After one to three minutes of "no flow" stabilization, check the observed reading against the flow meter's data tag or last line(s) of your meter's Certificate of Conformance.
3. A value within 5 milliwatts of the original Factory value (assuming the same gas is checked at same pressure) indicates that meter still has the original calibration data.
4. A value greater than 5 mW, but less than or equal to 10 mW, also indicates that the meter still has the original calibration data, but this reading may have been influenced by one or more of the following factors: gas composition, pressure, dirt, non-zero conditions, and sensor orientation. Any of these factors can have an effect on the mWo. It is a very sensitive data point; that is why it is such a good check.

5. Note, if all of the above factors were remedied, it would be expected that the mWo would report less than or equal to 5 milliwatts.
6. Note, in some cases, contamination of the sensor is the only cause of the additional heat transfer during the "no flow" test. Remove probe, and clean the sensor (use an appropriate non-corrosive solvent to remove build up). A soft brush can be used to gently clean the sensing surface, using caution to avoid damaging the sensor elements (the RTD's).
7. In summary, if a technician in the field were able to simulate Sage calibration conditions exactly, he too would find that the mWo would be within 1 mW or very close to that. Since this is not always possible, we are finding that after considering all of the field variables, a mWo in the field that is within 10 milliwatts is an acceptable value (see 9). This would allow for a check to be done in the pipe under application conditions.
8. Note, if desired, a second check can be conducted as well, but using ambient air: This validation method requires that the sensor be removed from the pipe and inserted in a container such as an empty plastic water bottle. The mW value for ambient air can be found on the Certificate of Conformance supplied with the meter.
9. For CAR¹ compliance (for the protocols listed below), Sage recommends (but does not require) a periodic validation check, at least annually, by following the Situ Verification Procedure. Alternately, at User's discretion, the Sage flow meter can be shipped back to Sage for a calibration check. Prior to shipping, please obtain a Return Meter Authorization (RMA) from the Service Department.
U.S. Landfill Protocol, Version 4.0, Par. 6.2
Mexico Landfill Protocol, Version 1.1, Par. 6.2
U.S. Livestock Protocol, Version 3.0, Par. 6.2
U.S. Livestock Protocol, Version 4.0, Par. 6.3
Mexico Livestock Protocol, Version 2.0, Par. 6.2
As per the protocols, the maximum allowable drift is 5%.
10. If the mW reading exceeds ± 10 mW of the original factory value, the error across the full calibration range would not be field-determinable, however the Flow Meter can be returned for an "As-Found" comparison to the original calibration data and/or for recalibration.

¹ CAR is the Climate Action Reserve. The Climate Action Reserve is a national offsets program working to ensure integrity, transparency and financial value in the U.S. carbon market. It does this by establishing regulatory-quality standards for the development, quantification and verification of greenhouse gas (GHG) emissions reduction projects in North America. The Climate Action Reserve operates alongside its sister program, the California Climate Action Registry (California Registry), which was created by the State of California in 2001 to address climate change through voluntary calculation and public reporting of emissions.

² CDM Methodologies, ACM 0001, "Methodological tool to determine the mass flow of a greenhouse gas in gaseous stream" (EB61 Report, Annex 11, Page 1).

³ Sage "zeros" the meter in a horizontal pipe. If you have a vertical pipe, mW will be slightly lower at zero (also see note 4).

⁴ The allen wrench to loosen collar clamp is $\frac{3}{8}$ " on the SVA05 (it is $\frac{1}{2}$ " on the SVA07).

Section

E

**WARRANTIES AND
SERVICE WORK**

Warranties and Service Work

LIMITED WARRANTY

Sage Metering's products are warranted against faulty materials or workmanship for one year from the date of shipment from the factory. Sage's obligation is limited to repair, or at its sole option, replacement of products and components which, upon verification by Sage at our factory in Monterey, California, prove to be defective. Sage shall not be liable for installation charges, for expenses of Buyer for repairs or replacement, for damages from delay or loss of use, or other indirect or consequential damages of any kind. This warranty is extended only to Sage products properly used and properly installed for the particular application for which intended and quoted; and does not cover water damage due to improper use of cord grips or removal of protective caps; and does not cover Sage products which have been altered without Sage authorization or which have been subjected to unusual physical or electrical stress. Sage makes no other warranty, express or implied, and assumes no liability that goods sold to any purchaser are fit for any particular purpose. Transportation charges for materials shipped to the factory for warranty repair are to be paid by the shipper. Sage will return items repaired or replaced under warranty, prepaid.

NOTE: No items will be returned for warranty repair without prior written authorization from Sage Metering, Inc. Sage does not warranty damage due to corrosion.

GENERAL TERMS AND CONDITIONS

Detailed General Terms and Conditions can be found on the Sage website (www.sagemetering.com) on a link "General Terms" on the Footer of any page on the website.

CANCELLATION / RETURN POLICY

Cancellation or Return: After issuance of a purchase order (by phone, mail, e-mail or fax) or a credit card order (by phone, mail, e-mail or fax), there will be a cancellation fee for any cancelled order. Cancellations must be in writing (by mail, e-mail or fax):

- 1) If credit card order or non-credit card order is cancelled within 7 days of issuance of purchase order or date order was placed (which ever is earlier), there will be a 10% cancellation fee.
- 2) If credit card order or non-credit card order is cancelled after 7 days, but prior to shipment, there will be a 20% cancellation fee. (If order is cancelled due to late delivery, the cancellation fee will be waived. Late delivery is defined as shipping a meter 7 days or later than the delivery date acknowledged by Sage Metering at time of placing order).
- 3) If a credit card customer decides to return the equipment after shipment for credit, credit will not be issued if equipment is damaged or if equipment is returned after four (4) months of shipment. If equipment is not damaged, then equipment can be returned after issuance of a Return Meter Authorization (RMA) by Sage. Returned package must be insured by customer and must reference proper RMA# on outside of package, or package may be rejected (i.e., package will be returned unopened). Credit Card customers will be charged a 30% re-stocking fee (70% balance will be credited back). Customer is responsible for return shipping charges and any damage if improperly packaged.

continued on next page

- 4) If a non-credit card customer decides to return the equipment after shipment for credit, credit will not be issued if equipment is damaged or if equipment is returned after 1 month of shipment, unless authorized by a representative at Sage Metering, Inc. The Sage representative will issue a Return Material Authorization (RMA) at that time and will advise of the restocking fee. Returned package must be insured by customer and must reference proper RMA# on outside of package, or package may be rejected (i.e., package will be returned unopened). Customer is responsible for return shipping charges and any damage if improperly packaged.

RETURNING YOUR SAGE METER

A Return Material Authorization Number (RMA#) must be obtained prior to returning any equipment to Sage Metering for any reason. RMA#s may be obtained by calling Sage Metering at 831-242-2030 between 7:00 am and 4:00 pm Monday through Friday, or email: service@sagemetering.com.

A Sage RMA Form (see page 60) must be filled out and included with the meter being returned to Sage Metering. RMA Form is also accessible by clicking the “Contact” tab of the Sage website (www.sagemetering.com).

Take special care when packaging your meter for return to the factory. The sensor in particular may easily be damaged if not prevented from shifting around within the package and if the sensor itself is not covered to keep it from contacting other package contents. Any damage resulting from improper packaging is the responsibility of the shipper.

Once an evaluation is completed and a quote has been issued, you can choose to proceed with the work or have the unit returned with only the evaluation fee in the amount of \$175 plus freight billed.

In accordance with the “Right to Know Act” and applicable US Department of Transportation (DOT) regulations, Sage Metering will not accept delivery of equipment that has been contaminated without written evidence of decontamination, and has instituted the following Return/Repair conditions. Strict adherence to these conditions is required. Returned equipment that does not conform to the requirements listed below will not be processed. If Sage Metering finds evidence of contamination, we may, at our option, have the unit returned at your expense. For your reference, the requirements for packaging and labeling hazardous substances are listed in DOT regulations 49 CFR 172, 178, and 179.

1. The equipment must be completely cleaned and decontaminated prior to shipment to Sage Metering. This decontam-

ination includes the sensor, probe, electronics and enclosures internally and externally. All packaging must be clean and free from contamination.

2. A Material Safety Data Sheet (MSDS) is required for all process fluids and gases that have been in contact with the equipment. This includes fluids or gases used in cleaning the equipment. A Decontamination Statement is also required for each meter returned using a different gas or fluid. Both the MSDS and the Decontamination Statement are to be attached to the OUTSIDE of the shipping container. If both documents are not attached, you will be called, and the equipment sent back to you at your expense.
3. The decontamination Statement must include the following required information
 - A. A list of all chemicals and process fluids used in the equipment, including decontamination fluids or gases.
 - B. The model and serial number of the equipment being returned.
 - C. A company officer or other authorized person’s signature on the statement.

Return Shipping Address:

ATTENTION:

Sage Metering, Inc.
8 Harris Court, Building D1
Monterey, CA 93940

All shipments should be sent Freight Prepaid. Collect shipment may be refused or the freight costs may be billed back as part of the service.

RETURN MATERIAL AUTHORIZATION

You may pre-mail your purchase order to: service@sagemetering.com
Or fax directly to Fax # 1-831-655-4965

RMA # _____

Date _____

RETURN CUSTOMER INFORMATION

Customer's Name _____ Fax # _____

Customer's Contact Name _____ Phone # _____

Email Address _____

CUSTOMER'S RETURN ADDRESS

Bill To: _____ Ship To: _____

Street: _____ Street: _____

City: _____ City: _____

State: _____ Postal Code: _____ State: _____ Postal Code: _____

Country: _____ Country: _____

CUSTOMER'S SHIPPING ACCOUNT NUMBER Check type of account

UPS _____ FedEx _____ DHL _____ Other _____ ACCOUNT # _____

RETURN PRODUCT INFORMATION

Model No. _____ Serial No(s). _____

FLOW: MIN _____ NORMAL _____ MAX _____

TEMP: MIN _____ NORMAL _____ MAX _____

PRESSURE: MIN _____ NORMAL _____ MAX _____

PIPE SIZE/DUCT: _____ GAS: _____ OTHER: (special mix) _____

REASON THE METER(S) IS BEING RETURNED AND DESCRIPTION OF SYMPTOMS:

(All non-warranty repairs could be subject to a minimum evaluation charge)

Sage Metering Technical Contact _____

All equipment must be clean and free of any contamination. All "contaminated" equipment will be subject to additional cleaning fee and delays in processing.

Take special care when packaging your meter for return to the factory. The sensor in particular may easily be damaged if not prevented from shifting around within the package and if the sensor itself is not covered to keep it from contacting other package contents. Any damage resulting from improper packaging is the responsibility of the shipper.

GENERAL TERMS AND CONDITIONS: Detailed General Terms and Conditions can be found on the Sage website (www.sagemetering.com) on a link "General Terms" on the Footer of any page on the website.

SAGE METERING, INC.

8 Harris Court, Building D-1 / Monterey, California 93940

PHONE: 831-242-2030 / FAX: 831-655-4965

Section

F

MODBUS

Modbus Register Listing

SAGE PRIME REV. 1.80–2.07

UINT32 Reg Offset	IEEE Float		SCALED INT32*		Reg Description
	Reg Offset	Type	Reg Offset	Type	
256		UINT8			format flag
256		UINT8			modbus_unit_id
257		UINT8			output mode sel
257		UINT8			fix_pt selection
257		UINT1			bRun
257		UINT1			bTotal
257		UINT1			bEEProm
257		UINT1			bReset
257		UINT1			bLeadEn
257		UINT1			bDAClo
257		UINT1			bDACHi
	514	FLOAT	770	LONG	CAL_VAL
	516	FLOAT	772	LONG	K-FACTOR
	518	FLOAT	774	LONG	VREF
	520	FLOAT	776	LONG	LOAD-RES
TEMP	522	FLOAT	778	LONG	COEFF A
TEMP	524	FLOAT	780	LONG	COEFF B
TEMP	526	FLOAT	782	LONG	COEFF C
TEMP	528	FLOAT	784	LONG	COEFF D
	530	FLOAT	786	LONG	DISP A
	532	FLOAT	788	LONG	DISP B
	534	FLOAT	790	LONG	DISP C
	536	FLOAT	792	LONG	DISP D
FLOW	538	FLOAT	794	LONG	COEFF A
FLOW	540	FLOAT	796	LONG	COEFF B
FLOW	542	FLOAT	798	LONG	COEFF C
FLOW	544	FLOAT	800	LONG	COEFF D
FLOW	546	FLOAT	802	LONG	COEFF E
FLOW	548	FLOAT	804	LONG	COEFF F

UINT32 Reg Offset	IEEE Float		SCALED INT32*		Reg Description
	Reg Offset	Type	Reg Offset	Type	
	550	FLOAT	806		iir filter coeff
	552	FLOAT	808		flow_min
	554	FLOAT	810		flow_max
	556	FLOAT	812		PULSE COUNT
	558	FLOAT	814		temp_max
302		UINT16			dac1_min
304		UINT16			dac1_max
306		UINT32			serial number
308		ASCII			RATE string
310		ASCII			TOTAL string
312		UINT32			current totalizer
314		UINT32			ADC0
316		UINT32			ADC1
318		UINT32			ADC2
320		UINT32			ADC3
	578	FLOAT	834	LONG	current flow
	580	FLOAT	836	LONG	current temp
	582	FLOAT	838	LONG	rtd_mWatts
	584	FLOAT	840	LONG	rtd_res
	586	FLOAT	842	LONG	ref_res_r
	588	FLOAT	844	LONG	ref_res_d
	590	FLOAT	846	LONG	dac_smooth
	592	FLOAT	848	LONG	lead
	594	FLOAT	850	LONG	oheat
	596	FLOAT	852	LONG	bv
	598	FLOAT	854	LONG	fv
	600	FLOAT	856	LONG	tv
	602	FLOAT	858	LONG	lv

*SCALED INT32 register contents form INT32 values by multiplying the IEEE FLOAT x 1000
ex. FLOAT -> 112.768 = SCALED INT32 -> 112768

Modbus Protocol & Function Codes

Sage Prime Meters support communication with other devices via MODBUS® protocol using RTU transmission mode. The Modbus protocol defines a message structure that controllers will recognize and use, regardless of the type of networks over which they communicate. It establishes a common format for the layout and contents of message fields. Transactions use a master-slave technique, in which only one device (the master) can initiate transactions (called queries). The other devices (the slaves) respond by supplying the requested data to the master and by taking the action requested in the query. Sage Meters operate as slaves to other Modbus devices and default to 19200-8-E-1, however, the following modes may also be software selectable:

- 9600-8-N-1 (Baud-Bits-Parity-Stop)
- 9600-8-E-1
- 9600-8-O-1
- 19200-8-N-1¹
- 19200-8-E-1 (Default)
- 19200-8-O-1

MESSAGE FRAMING

Messages start with a silent interval of at least 3.5 character times followed by 4 fields and then followed by another silent interval of at least 3.5 character times. The first field contains the device address. The second field contains the function code. The third field contains the data and byte counts. The fourth field contains the CRC value.

¹ Parity on the Wireless Devices manufactured by Obvius is "None" rather than "Even". The Sage default is 19200-8-E-1. Change to 19200-8-N-1 for the Obvius Modhoppers and related wireless devices.

ADDRESS FIELD

The address field contains one byte. Sage Prime Meters will transmit response packets to addresses which are between 1 to 240 decimal (inclusive). Modbus packet writes may be sent to broadcast address 00, however the Prime will not reply with a response packet.

FUNCTION CODE FIELD

The function code field contains one byte. See the section titled Function Codes Supported by Sage Prime.

DATA FIELD

The data field contains four or more bytes. This information is used by the Meter to take the action defined by the function code, or to read or write data to one or many registers.

CRC FIELD

The CRC-16 (cyclical redundancy check) field is two bytes, containing a 16-bit binary value. The CRC value is calculated by the transmitting device, which appends the CRC to the message. The receiving device recalculates a CRC during receipt of the message, and compares the calculated value to the actual value it received in the CRC field. If the two values are not equal, the message will be discarded.

Function Codes Supported by SAGE Prime

03 (0X03) READ HOLDING REGISTERS

Identical operation as code 04 READ INPUT REGISTERS described below, except READ only.

04 (0X04) READ INPUT REGISTERS

Reads the binary contents of the specified register. This is READ/WRITE register. Sage Prime values are typically 32 bits wide (4 bytes) and contain a single IEEE754 floating point value. Modbus registers are 16 bits wide (2 bytes) so a minimum of 2 Modbus registers are required to transfer all floating point bits to the master. See section titled Sage Floating Point Format.

QUERY

The query message specifies the starting register address and the quantity of registers to be read.

0x03 READ MULTIPLE HOLDING REGISTERS or
0x04 READ MULTIPLE INPUT REGISTERS

-QUERY-	-RESPONSE-
SA – SLAVE ADDRESS	SA
04 – FUNC CODE	04
RH – REG ADDR HI	BC – # of data bytes to follow
RL – REG ADDR LO	DATA0
00 – # OF REGS HI	DATA1
CT – # OF REGS LO	DATAn
CH – CRC MSB	CH CRC MSB
CL – CRC LSB	CL CRC LSB

REG ADDR HI (RH) is set to:

- 01 for INTEGER access of integral values
- 02 for IEEE754 floating point
- 03 for Scaled (x1000) long integer of floating point value

REG ADDR LO (RL) is the starting address index into the register structure. See section titled Sage Register Index Values.

CT is the register count needed to transfer data. Typically this byte is set to 02 to request 1 full IEEE754 floating point value. (Modbus single registers are 16 bits wide, Sage floating point values are 32 bits wide.)

DATA0-DATAn are bytes in binary format returned from the slave device representing the contents of the selected register(s).

NOTE: values indicated with 0x prefix are in hexadecimal, otherwise in decimal notation.

16 (0x10) WRITE REGISTERS

Writes the binary contents of the specified register into the meter. Sage Prime values are typically 32 bits wide (4 bytes) and contain a single IEEE754 floating point value. Modbus registers are 16 bits wide (2 bytes) so a minimum of 2 Modbus registers are required to transfer all floating point bits into the meter. See section titled Sage Floating Point Format.

Query

The query message specifies the starting register address and the quantity of registers to be written.

16 (0x10) WRITE MULTIPLE REGISTERS

-QUERY-	-RESPONSE-
SA – SLAVE ADDRESS	SA
0x10 – FUNC CODE	0x10 – 16 FUNC CODE
RH – REG ADDR HI	RH – REG ADDR HI
RL – REG ADDR LO	RL – REG ADDR LO
00 – # OF REGS HI	00 – # REGS HI
CT – # OF REGS LO	CT – # REGS LO
BC – BYTES COUNT	CH – CRC MSB
DATA0	CL – CRC LSB
DATA1	
DATAn	
CH – CRC MSB	
CL – CRC LSB	

REG ADDR HI (RH) is set to:

- 01 for INTEGER access of integral values
- 02 for IEEE754 floating point
- 03 for Scaled (x1000) long integer of floating point value

REG ADDR LO (RL) is the starting address index into the register structure. See section titled Sage Register Index Values.

CT is the register count needed to transfer data. Typically this byte is set to 02 to request 1 full IEEE754 floating point value.

BC is the actual number of bytes that follow.

DATA0-DATAn are bytes in binary format transmitted to the slave device representing the contents of the selected register(s).

NOTE: THIS PAGE APPLIES TO REV. 1.81–1.83

17 (0x11) REPORT SLAVE IDENTIFICATION*

This query requests from the specified slave address a detailed identification packet with a run status, and Sage Prime and firmware revision response. (Prime will not respond to broadcast slave address 00.)

Query

The query message specifies the slave address, function code, and CRC check words.

17 (0x11) REPORT SLAVE ID

-QUERY-	-RESPONSE-
SA – SLAVE ADDRESS	SA
11 – FUNC CODE	11
CL – CRC LSB	BC – BYTES COUNT, 19
CH – CRC MSB	SD – SLAVE ID (DEVICE SPECIFIC), 0x5A
	RS – RUN STATUS INDICATOR, 0xFF
	ASCII Text – SAGE PRIME v1.81x
	CH
	CL

Response

The Sage Prime will respond with an echo of the slave address and function code. The byte count will be 19 (0x13) to allow the master to account for all the remaining bytes that follow.

REPORT SLAVE ID Example: **MODBUS SLAVE ADDRESS (0X31 Hex=49 Decimal default)**

Master Query -> 30 11 D5 BC

Prime Response -> 30 11 13 5A FF 53 61 67 65 20 50 72 69 6D 65 20
76 31 2E 38 31 20 F1 2B

ASCII translation-> Sage Prime v1.81

ILLEGAL FUNCTION CODES*

The Sage Prime will respond to other Modbus function codes not documented in this revision, these codes are considered unsupported by Sage Metering.

Unsupported function codes will cause the Prime to reply with Modbus ILLEGAL FUNCTION status.

*Not implemented in revision 1.80

SAGE REGISTER INDEX VALUES

DATA TYPE	VALUE	SIZE	INDEX	ADDRESS DESCRIPTION
Byte	slave_ad	1 BYTE	1	Modbus Slave Address*
float	flow_rate;	1 IEEE754	578	actual flow rate
float	flow_temp;	1 IEEE754	580	process temperature
float	rtd_mWatts;	1 IEEE754	582	sensor power reading
float	rtd_res;	1 IEEE754	584	actual sensor probe resistance
float	ref_res_r;	1 IEEE754	586	actual temperature probe resistance
integ	totalizer;	1 uLONG	312	actual displayed total

*NOTE: Sage Prime Meters are factory programmed with the **MODBUS**

SLAVE ADDRESS (0X31 Hex=49 Decimal default)

It may be extremely useful to be able to write to an unknown slave address with a simple broadcast command. Be sure only one Sage Prime is connected during any broadcast writes using slave address = 0.

Writing into unspecified registers (not defined above) can render the unit non-functional or overwrite factory calibration data yielding incorrect operation.

EXAMPLE MODBUS PACKET

Query

This packet will request of the addressed slave to respond by sending back the contents of registers 578 to 582 (inclusive).

Three registers: flow rate through RTD mWatts in IEEE754 floating point

format.

```

0x31 – MODBUS SLAVE ADDRESS (0X31 Hex=49 Decimal default)
0x04 – READ INPUT REGS FUNCTION CODE
0x02 – STARTING REGISTER HI BYTE (0x01 = 256, 0x02 = 512, 0x03
= 768)
0x42 – STARTING REGISTER LO BYTE (512 + 66 = register access =
578)
0x00 – COUNT MSB (ALWAYS ZERO)
0x06 – COUNT OF ALL DESIRED REGISTERS
0xD5 – CRC HI BYTE
0x85 – CRC LO BYTE

```

Sage Register Output Format

INTEGER REPRESENTATION

Computer systems hosting a MODBUS network typically store integer values to represent non-fractional quantities.

All registers addressed above 256 (0x0100-0x1FF) will transfer 16 bit integral quantities in response to all master queries. MODBUS requires that the register count reflects each 16 bit registers transmitted to ensure that no bytes are missing in the transfer of integer quantities. (Note: Most Sage Prime registers are IEEE754 quantities; integer representations of these registers will require significant translation.)

IEEE754 FLOATING POINT

Computer systems hosting a MODBUS network typically store single precision floating point data in the standard IEEE754 format.

All registers addressed above 512 (0x0200-0x02FF) will transfer full 32 bit single precision quantities in response to all master queries. MODBUS requires that two 16 bit registers are transmitted to ensure that no bytes are missing in the transmission of 32 bit quantities.

SCALED DECIMAL REPRESENTATION

Computer systems hosting a MODBUS network may choose represent single precision floating point values as scaled long integers (32 bit values). The Sage Prime will convert floating point registers to integral units by multiplying the value by 1000.

Ex. Floating point value 1234.567 will be converted to integral value 1234567

All registers addressed above 768 (0x0300-0x03FF) will transfer full 32 bit scaled integer quantities in

response to all master queries. MODBUS requires that two 16 bit registers are transmitted to ensure that no bytes are missing in the transmission of 32 bit quantities.

For more information on the MODBUS protocol, see: <http://www.modbus.org/tech.php>

SAGE ADDRESSER SOFTWARE

Addresser is a convenient software kit that includes Addresser software, as well as an optically isolated ULINX RS485 to USB converter. The Addresser is a READ/WRITE Program with drop-down menus for convenient user interface between your PC or laptop and the Modbus Terminals of the Sage Prime. Contact Sage for ordering information and instructions.

SAGE ADDRESSER TECHNICAL ASSISTANCE

Visit our website at www.sagemetering.com, select "Knowledge Base" and "Service Manuals & Guides" then select "PRO-PRM-080911 Website Addresser 3_14" or "Modbus Poll Instructions".

Sage Addresser Typical Printout (Version 3.14)

SMB Printout
Serial# 50043

Units: SCFM Modbus:
0x31

6/23/2011
12:01:50 PM

Parameter	Decimal Data	Hex Format
Calib mW Val	44.91799	8433AC08
K-Factor	1.000000	7F000000
Lead Gain Val	0.992098	7E7DFA22
Flow Load Res	20.10000	8320CCCD
Temp Calib[A]	-3.07714	80C4F000
Temp Calib[B]	1.144714	7F128600
Temp Calib[C]	-0.00121	759F7000
Temp Calib[D]	0.000003	6C3F3400
Temp Disp Null	0.000000	00000000
Temp Disp Gain	1.000000	7F000000
Amp Null Val	-0.16634	7CAA56DE
Amp Gain Val	1.008498	7F011676
Flow Coeff[A]	-20.7094	83A5ACF2
Flow Coeff[B]	0.720296	7E38654E
Flow Coeff[C]	-0.00880	789033FC
Flow Coeff[D]	0.000067	710D75E4
Flow Coeff[E]	0.000000	00000000
Flow Coeff[F]	0.000000	00000000
Filtering	0.500000	7E000000
Min Flow/LFC	0.000000	00000000
Full Scale	1200.000	89160000
Min Temp	40.00000	84200000
Units/Pulse	100.0000	85480000
DAC1 Min	725.0000	000002D5
DAC1 Max	3674.000	00000E5A
Serial Number	50043.00	0000C37B
Flow Units	12964504	4D464353
Total Units	11790099	46464353
Output Config	8.000000	00000008
Pulse Dur	250.0000	000000FA

Section

G

HART

HART Menu Tree

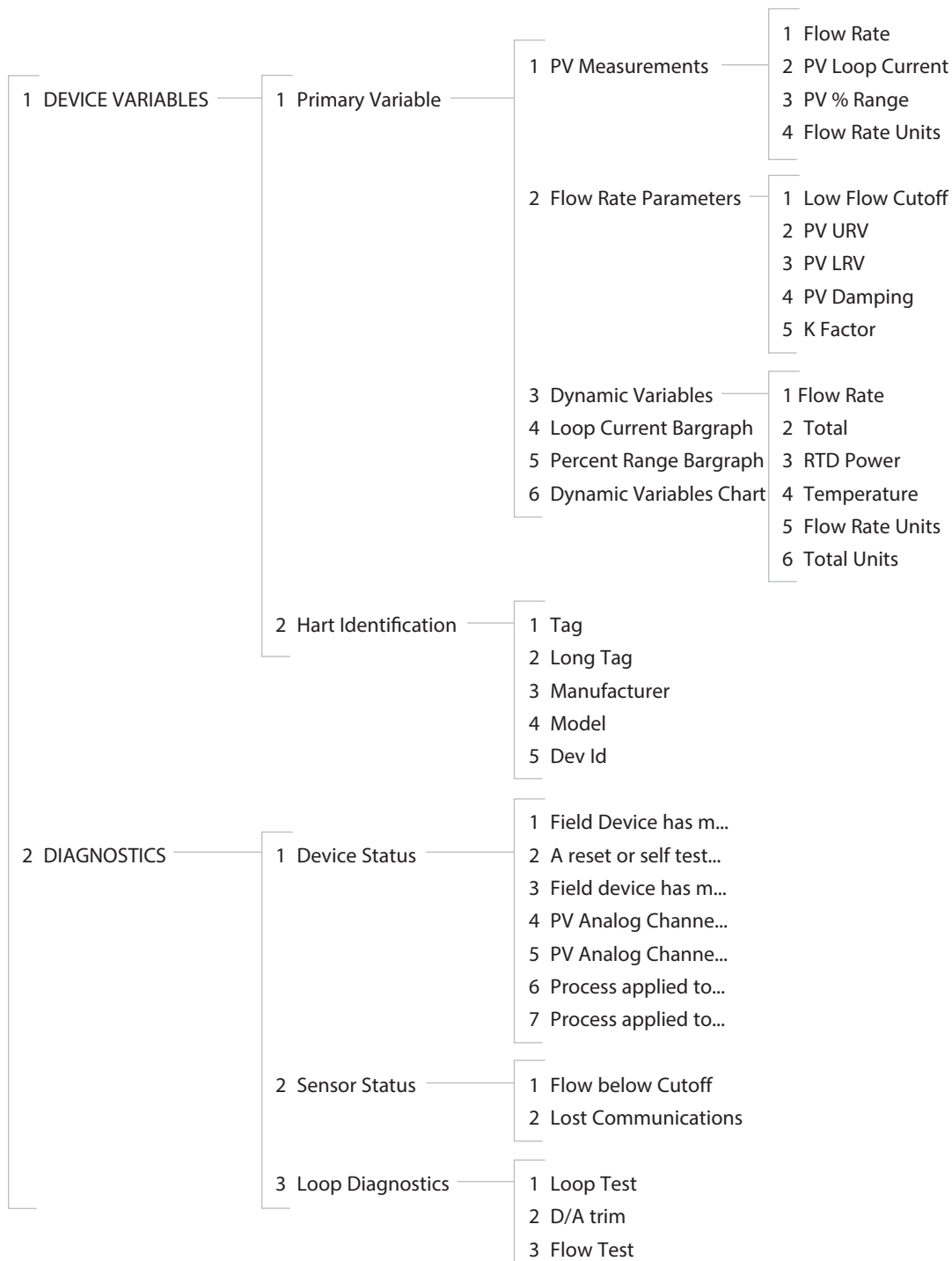

DEFAULT:
 PV = Flow
 SV = Temperature
 TV = Total

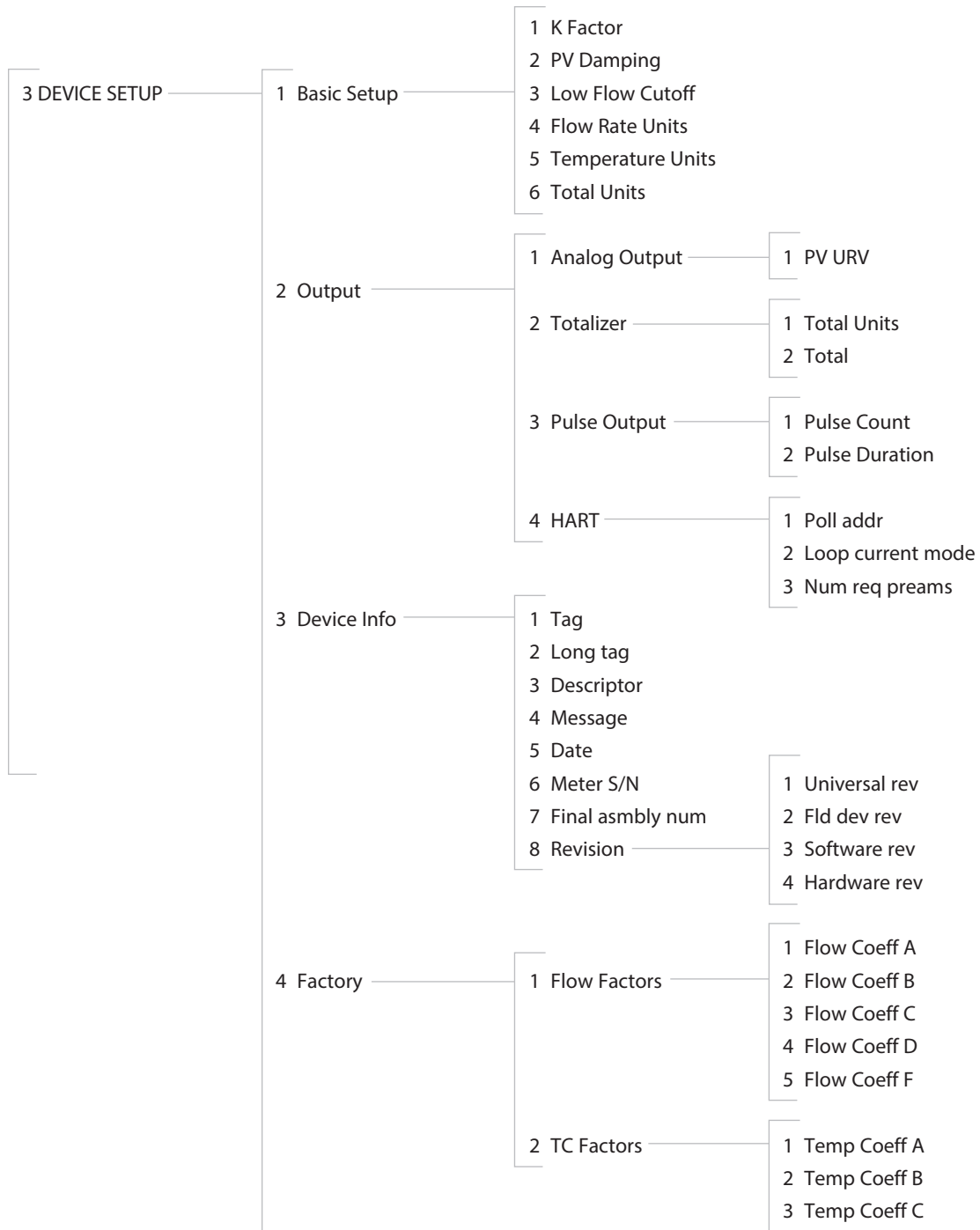

HART

Following reviews the various parameters used in the HART menu structure and provides fast keys for accessing this information:

PRIMARY VARIABLE - READ ONLY

Provides information regarding the Primary Variable (Flow)

PV MEASUREMENTS

FLOW RATE [Fast Key 1,1,1,1]

Actual measurement of the flow rate in the reference unit of measurement

PV LOOP CURRENT [Fast Key 1,1,1,2]

Analog value output ranging between 4 and 20 mA representing the flow rate. The 4 and 20 mA loop can be verified by using the Loop Test described below in the Diagnostic section [Fast Key 2,3,1].

PV % OF RANGE [Fast Key 1,1,1,3]

Provides the value of the flow rate representing the % of range between the LRV (Lower Range Value) and the URV (Upper Range Value).

FLOW RATE UNITS [Fast Key 1,1,1,4]

Units of measurement associated with the flow rate.

FLOW RATE PARAMETERS

LOW FLOW CUTOFF [Fast Key 1,1,2,1]

Any measured flow rate below this value will be set to 0.

PV URV [Fast Key 1,1,2,2]

Upper Range Value of the Primary Variable. Represents the 20 mA value

PV LRV [Fast Key 1,1,2,3]

Lower Range Value of the Primary Variable. Represents the 4 mA value. Value is 0.

PV DAMPING [Fast Key 1,1,2,4]

Primary Variable Damping factor. Used to smooth out normal occurring fluctuations in the flow rate. Values range between .001 and .999 which represents no smoothing. Lower values increase damping.

K FACTOR [Fast Key 1,1,2,5]

K Factor is a linear adjustment factor which may be used to adjust the flow rate for various reasons requested by the user. Default is 1.

DYNAMIC VARIABLES

FLOW RATE [Fast Key 1,1,3,1]

Displays the current flow rate measured by the flow meter.

TOTAL [Fast Key 1,1,3,2]

Displays the total flow measured by the instrument.

RTD POWER [Fast Key 1,1,3,3]

Measurement of the power in mW corresponding to the measured flow rate. Useful for diagnostic purposes

TEMPERATURE [Fast Key 1,1,3,4]

Displays the gas temperature where the sensor is located

FLOW RATE UNITS [Fast Key 1,1,3,5]

Units of measurement of the flow rate

TOTAL UNITS [Fast Key 1,1,3,6]

Units of measurement of the total flow

LOOP CURRENT BARGRAPH [Fast Key 1,1,4]

Displays a graphic chart showing the mA output of the flow rate vs. time – Range between 4 and 20 mA

PERCENT RANGE BARGRAPH [Fast Key 1,1,5]

Displays a graphic chart showing the flow rate as a % of range between the LRV and URV

DYNAMIC VARIABLES CHART [Fast Key 1,1,6]

Displays a graphic chart showing flow rate in selected units of measurement vs. time

HART IDENTIFICATION

TAG [Fast Key 1,2,1]

A Tag value entered by the user to identify the flow meter. Up to 8 digits in length

LONG TAG [Fast Key 1,2,2]

A value entered by the user

MANUFACTURER [Fast Key 1,2,3]

The name of the Manufacturer of the flow meter. In this case it is Sage Metering

MODEL [Fast Key 1,2,4]

Manufacturer's model number of the flow meter.

DEVICE ID [Fast Key 1,2,5]

Factory entered number which is unique for each instrument

DIAGNOSTICS**DEVICE STATUS** [Fast Key 2,1]

Will indicate any standard diagnostics message

SENSOR STATUS**FLOW BELOW CUTOFF** [Fast Key 2,2,1]

Diagnostics menu indicating that the measured flow rate is less than the low flow cutoff

LOOP DIAGNOSTICS**LOOP TEST** [Fast Key 2,3,1]

Permits the user to drive the mA output to a desired value.

D/A TRIM [Fast Key 2,3,2]

Used to calibrate the 4-20 mA output from the flow meter to match the system loop.

FLOW TEST [Fast Key 2,3,3]

Permits user to enter a value for the RTD Power with the display showing expected flow rate based on original calibration. Useful diagnostics test to insure that the flow meter is matching the original calibration curve.

DEVICE SETUP**BASIC SETUP****K FACTOR** [Fast Key 3,1,1]

Enter a K factor which will provide a linear adjustment of the flow rate. May be used to correct for different pipe size, varying gas composition, or installation effects which change the performance of the flow meter.

PV DAMPING [Fast Key 3,1,2]

Provides smoothing of normally occurring flow fluctuations. Value between 0.001 to 0.999; the lower the value providing greater smoothing (time averaging).

LOW FLOW CUTOFF [Fast Key 3,1,3]

Enter a minimum value of the flow rate. Flow rates measured below this value will be shown as zero flow. Useful to disregard any false readings which might occur during a no flow condition

FLOW RATE UNITS [Fast Key 3,1,4]

Units of measurement of the flow rate. This is a text entry. Any change in units of measurement from original calibration must also apply a K factor

TEMPERATURE UNITS [Fast Key 3,1,5]

Displays the units of measurement of the gas temperature

TOTAL UNITS [Fast Key 3,1,6]

Four digit entry. The first three digits will represent the units of measurements of total flow and the fourth digit will be "C" or "F" to identify units of measurement of the temperature reading.

OUTPUT**ANALOG OUTPUT****PV URV** [Fast Key 3,2,1,1]

Enter the Upper Range Value for the Primary Variable (flow rate). The URV must be in the identified units of measurement and must be within the calibration range of the instrument. Consult Sage Metering if assistance is required.

TOTALIZER**TOTAL UNITS** [Fast Key 3,2,2,1]

Displays the units of measurement for the totalized value.

TOTAL [Fast Key 3,2,2,2]

Displays the totalized value in the selected units of measurement.

PULSE OUTPUT**PULSE COUNT** [Fast key 3,2,3,1]

Provides the number of units per pulse. Example will be a Pulse Count of 100 and units are set to SCF, then one pulse is equivalent to 100 SCF.

Pulse Duration [Fast Key 3,2,3,2]

HART**POLL ADDRESS** [Fast Key 3,2,4,1]

Used multi drop installations to identify an individual instrument. Values can range between 1 and 15. If used in a multi drop configuration the 4-20 mA output will be set to 4 mA. The default setting is a Poll Address = 0 with the 4-20 mA analog signal operational.

LOOP CURRENT MODE [Fast Key 3,2,4,2]

Allows the user to select whether the loop current is enabled (active) or disabled (fixed at 4mA) regardless of the poll address setting.

Number of Request Preambles [Fast Key 3,2,4,3]

Required HART command – indicates the number of preambles required by the instrument for HART communication.

DEVICE INFORMATION**TAG** [Fast Key 3,3,1]

Enter a 8 digit tag which can be used to identify the instrument

LONG TAG [Fast Key 3,3,2]

Enter up to a 32 digit tag which can be used for any purpose desired by the user.

DESCRIPTOR [Fast Key 3,3,3]

A 16 character entry which can be used for additional identification of the instrument.

MESSAGE [Fast Key 3,3,4]

A 32 character entry which can be used for identification or other purposes.

DATE [Fast Key 3,3,5]

Enter date code; often used to enter last date a configuration change had been made.

METER S/N [Fast Key 3,3,6]

Factory entry of the serial number of the instrument

FINAL ASSEMBLY NUM [Fast Key 3,3,7]

User entered identification which may be used for future reference

REVISIONS:

- Universal Revision Number [Fast key 3,3,8,1]
Identifies the HART specification used in the design of the instrument.
- Field Device Revision Number [Fast Key 3,3,8,2]
Provides the instrument revision for HART compatibility
- Software Revision Level [Fast Key 3,3,8,3]
Provides the software revision used by the instrument
- Hardware Revision Level [Fast Key 3,3,8,4]
Provides the Hardware revision level of the instrument

FACTORY

Flow Factors and TC Factors

Displays factory entered calibration values for the instrument

Section

H

APPENDIX

Sage Prime Service Department “Dongle”

Although virtually any setting on Sage Prime can be changed by users who have Modbus® capability via Terminals C1, C2 and C3 (see wiring illustrations), not all customers have that capability to communicate with the Prime using its Modbus Compliant RS485 Communications. However, users do not need to have a Modbus host or any special skill, since they can also change selected configurations in the field by using the patent pending Sage “Dongle”.

The Sage Prime device known as a “Dongle”, was developed to facilitate making very basic changes on Sage Prime Flow Meter settings in the field. Simply contact the Sage Service Department and specify your requirement (such as the new Full Scale, new Pipe Area, etc), and the device will be programmed at Sage and sent directly to you within a few days (there is a slight fee for this service). The patent-pending Dongle can also be configured as a Reset Totalizer device (i.e. it can be used repeatedly, with any Sage Prime to easily reset the Totalizer). The Dongle can also be programmed to change Engineering Units, Filter Response and numerous other parameters.

Dongles come with a convenient well marked cable that

is connected to the RS485 terminals. First disconnect the power. Then remove the rear cover and connect the Dongle wires to terminals C1, C2 & C3. There is a button on the Dongle, push this button within the first 10 seconds as soon as you power up the meter. An LED will illuminate, and within 3 seconds the light will go out signaling that the data transfer is complete. Remove the Dongle, close the cover, and you will notice that the new settings have been uploaded (or in the case of a Totalizer-Reset Dongle, you will notice that the Totalizer has zeroed).



¹ If the light does not go out, it will be necessary to repeat procedure. Remove finger for a few seconds and then push button again.

Correction Factors For Variation From Original Digester Gas Calibration

Sage can calibrate for any Digester Gas, Bio Gas or Landfill Gas Mix. However, it may be helpful to have correction factors for a typical calibration, in the event that the composition changes after delivery. The following examples assume that the initial calibration was set up for 60% CH₄ and 40% CO₂.

- a) 65% CH₄ and 35% CO₂: Multiply reading by 0.982 to correct it for new composition
 - b) 70% CH₄ and 30% CO₂: Multiply reading by 0.965 to correct it for new composition
 - c) 55% CH₄ and 45% CO₂: Multiply reading by 1.0185 to correct it for new composition
- For smaller changes, the corrections are linear in between
- d) Also, if 100% saturated with H₂O vapor (non-condensing), multiply readings by 1.042
 - e) If 50% saturated with water, multiply reading by 1.021
(Water vapor correction is linear in between)

Also, use the 45 degree mounting method in order to avoid droplets from hitting the sensor and causing spikes (see above right)

Installations Where Pipe Condensation May Develop



TILT ENCLOSURE 45°
(forward or backward)
FOR APPLICATIONS WHERE
CONDENSATION MAY DEVELOP
ON INSIDE WALL OF PIPES

J-Box and Upstream Orientation

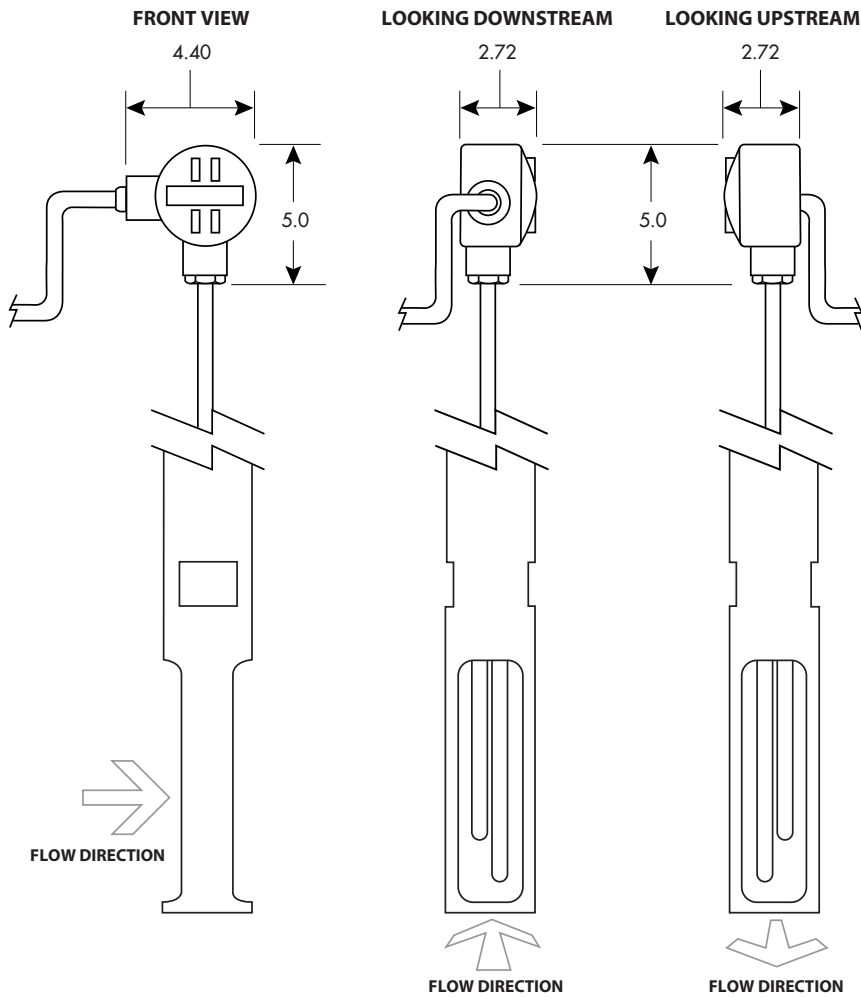

What is a Thermal Mass Flow Meter?

- What is a Thermal Mass Flow Meter? It is a meter that directly measures the gas mass flow based on the principle of conductive and convective heat transfer.
- All Meters have probes (Insertion Style) or Flow Bodies (In-Line Style) that support a pair of sensors, which are in contact with the gas.
- The sensors are RTDs, which are resistance temperature detectors. They consist of highly stable reference-grade platinum windings. In fact, we use the same material that is used as Platinum Resistance Standards at the NIST.
- The RTDs are clad in a protective 316 SS sheath for industrial environments.
- One of the RTDs [See Diagram below] is self-heated by the circuitry and serves as the flow sensor. The other RTD acts as a reference sensor, and measures the gas temperature. Essentially it is used for temperature compensation.
- The Sage proprietary hybrid-digital sensor drive circuitry maintains a constant overheat between the flow sensor and the reference sensor. As gas flows by the heated sensor (flow sensor), the molecules of flowing gas carry heat away from this sensor, and the sensor cools down as it loses energy. The circuit equilibrium is disturbed, and momentarily the temperature difference between the heated sensor and the reference sensor has changed. The circuit will automatically (within 1 second) replace this lost energy by heating up the flow sensor so the overheat temperature is restored.
- The current required to maintain this overheat represents the mass flow signal. There is no need for external temperature or pressure devices.

